



مركز الأمير سلمان لأبحاث الإعاقة
Prince Salman Center For Disability Research

علم ينفع الناس Science Benefiting People

www.pscdr.org.sa

Universal Accessibility

Building Environment

Guidelines for the Kingdom of Saudi Arabia

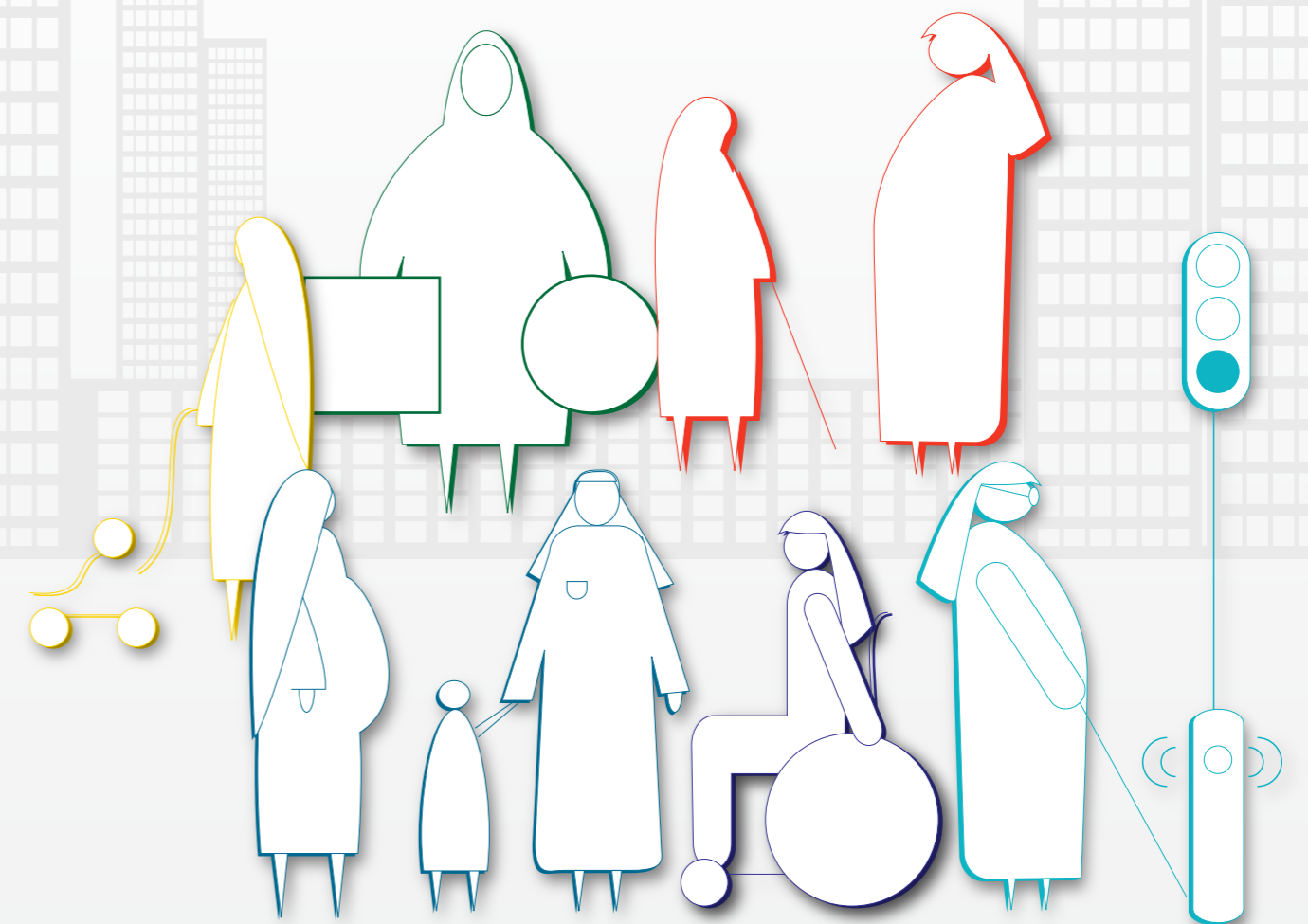

مركز الأمير سلمان لأبحاث الإعاقة
Prince Salman Center For Disability Research
علم ينفع الناس Science Benefiting People
www.pscdr.org.sa

Tel. +966 1 488 4401 | Fax. +966 1 488 4628 | www.pscdr.org.sa | info@pscdr.org.sa

ISBN: 978-603-00-5756-6

©Prince Salman Center for Disability Research, 2010
King Fahd National Library Cataloging-in-Publication Data
Prince Salman Center for Disability Research
Universal Accessibility Built Environment Guidelines
for the Kingdom of Saudi Arabia 1431H - 2010./ Prince Salman
Center for Disability Research- Riyadh 2010

304p; ..cm

ISBN: 978-603-00-5756-6

1-Physically handicapped -Home care
2-Handicapped-Service for - Saudi Arabia Title

362.409531 dc 1431/7477

L.D. no. 1431/7477
ISBN: 978-603-00-5756-6

The Universal Design is
Essential for 15%, Supportive to 40%, and Comfortable to 100%
of the Population



1.0 INTRODUCTION

1.1	Purpose of the UABE Manual	12
1.2	Context	12
1.3	Scope	12
1.4	How to Use the Manual	15

2.0 UNIVERSALLY ACCESSIBLE BUILT ENVIRONMENTS

2.1	Basic Concepts	21
2.2	Anthropometric Data	23

3.0 UABE TECHNICAL and DESIGN GUIDELINES

3.1 EXTERIOR ELEMENTS 36

3.1.1	Ground Surfaces	36
3.1.2	Overhead and Protruding Objects	39
3.1.3	Sidewalks, Pavements, Paths and Routes	42
3.1.4	Exterior Ramps	45
3.1.5	Exterior Stairs	51
3.1.6	Kerb Cut	55
3.1.7	Pedestrian Crossings	60
3.1.8	Medians and Middle Islands	63
3.1.9	Vehicle Parking	65
3.1.10	Passenger Drop-off Areas	73
3.1.11	Landscaping Materials and Plantings	76
3.1.12	Street Furniture	79
3.1.13	Gates and Turnstiles	82
3.1.14	Courtyards and Balconies	85

3.2 INTERIOR ELEMENTS 89

3.2.1	Entrances	89
3.2.2	Routes, Corridors and Access Aisles	92
3.2.3	Interior Ramps	96
3.2.4	Interior Stairs	102
3.2.5	Escalators	106
3.2.6	Lifts	107
3.2.7	Inclined and Vertical Platform Lifts	115
3.2.8	Moving Walks	119
3.2.9	Doors	124
3.2.10	Windows, Glazed Screens and Sidelights	134
3.2.11	Toilet Facilities	137
3.2.12	Ablution Spaces	142
3.2.13	Family Toilet Room	145



3.2.14	Toilet Stalls	150
3.2.15	Water Closets (WC)	156
3.2.16	Washbasins	160
3.2.17	Urinals	163
3.2.18	Toilet Accessories	167
3.2.19	Bathtubs	170
3.2.20	Showers	175
3.2.21	Grab Bars	180
3.2.22	Offices, Work Areas and Meeting Rooms	182
3.2.23	Kitchens and Kitchenettes	184
3.2.24	Dressing Rooms	192
3.2.25	Floor Surfaces	196
3.2.26	Overhanging and Protruding Objects	198
3.2.27	Gates, Turnstiles and Openings	202

3.3 AMENITIES 207

3.3.1	Information, Reception & Service Counters	207
3.3.2	Queuing and Waiting Areas	209
3.3.3	Viewing Spaces at Fixed Seating	211
3.3.4	Raised Platforms and Stages	215
3.3.5	Speaker Podiums & Lecterns	217
3.3.6	Tables, Counters and Work Surfaces	218
3.3.7	Rest Areas and Benches	220
3.3.8	Lockers & Baggage Storage	223
3.3.9	Storage, Shelving and Display Units	225
3.3.10	Controls and Operating Mechanisms	227
3.3.11	Ticketing and Vending Machines	230
3.3.12	Drinking Fountains	232
3.3.13	Handrails	236

3.4 COMMUNICATION AND SAFETY SYSTEMS 243

3.4.1	Signage	243
3.4.2	Public Telephones	248
3.4.3	Public Address Systems	252
3.4.4	Information Systems	253
3.4.5	Card Access, Safety and Security Systems	254
3.4.6	Detectable Warning Surfaces	256
3.4.7	Assistive Listening Systems	258
3.4.8	Visual Alarms	260
3.4.9	Emergency Exits, Areas of Rescue Assistance and Fire Evacuation	262



3.5	BUILDING-SPECIFIC REQUIREMENTS	269
3.5.1	Mosques	269
3.5.2	Office and Retail	270
3.5.3	Libraries	272
3.5.4	Indoor Recreational Facilities, Halls and Stadiums	276
3.5.5	Outdoor Recreational Facilities	277
3.5.6	Swimming Pools	280
3.5.7	Police Stations	283
3.5.8	Courthouses	285
3.5.9	Housing	288

Note: Refer to Universal Accessibility Land Transport Guidelines for transportation stop and terminal facility guidelines.

APPENDICES

A.	Glossary and Definitions	293
B.	Additional Design Considerations	295
B.1	Glare and Light Sources	295
B.2	Illumination	297
B.3	Materials and Finishes	299
B.4	Texture and Colour	300
B.5	Acoustics	302
C.	International Access Symbols	303
E.	References	305
F.	Subject Index	308
G.	Universal Accessibility Built Environment Checklist	312
H.	Feedback Form	313



Introduction





In 2007, the PSCDR embarked on a Universal Accessibility Program (UAP) culminating in the completion of a UAP Compendium in 2008. This comprehensive resource document evaluates and benchmarks the existing level of universal accessibility within KSA against acceptable standards and international best practices in four areas: built environment, land transportation, marine transportation and destination and accommodation. Based on the UAP compendium, four stand-alone, user-friendly working manuals are now available: one on Universally Accessible Land Transportation (UALT), Universally Accessible Building Environment (UABE), Universally Accessible Marine Transportation (UAMT), and Universally Accessible Destination and Accommodation (UADA).

The intended audiences of the Universal Accessibility Built Environment Guidelines Manual are planners, architects, engineers and interior designers, as well as other practitioners and decisions makers in the public and private sectors in KSA. The technical design guidelines will assist them in applying UABE principles and specifications to new building projects, and in the renovation of existing facilities to accommodate all members of Saudi society – including seniors and people with disabilities.

The UABE guidelines in this manual are prescriptive rather than performance-based. They are structured in a way to include considerations of the current conditions and unique cultural and administrative characteristics of the Kingdom of Saudi Arabia (KSA). The scope encompasses guidelines for Government/Administrative, Health Care, Education, Religion, Commercial, Recreation and Residential facilities. To facilitate practitioners in applying the UABE guidelines, two checklists have been compiled to facilitate on-site verification across KSA. In support of this validation process, users of the checklists are encouraged to provide comments and suggestions to the Prince Salman Centre for Disability Research using the Feedback Form.

The initial chapters of the UABE Guidelines Manual set the scene for the entire body of work, and explain the concept evolution and key terms that lay the foundations of a UABE. It is followed by the detailed technical design guidelines for all facilities. The appendices contain supporting documentation. Since the UABE guidelines were developed based on known best practices and expert opinions, and are subject to validation through accessibility audits, a feedback form is attached as an Appendix, to solicit users' comments for future enhancements.

“The issue of disability and its social and economic repercussions constitutes one of the most important challenges facing contemporary societies at present . . . (including) overcoming obstacles that constrain people with disabilities and limit their productivity and independence in society . . .”

**His Royal Highness Prince Sultan Bin Salman Bin Abdul-Aziz Al Saud,
Chairman of the Board
Prince Salman Center for Disability Research**



1.1 Purpose of the UABE Manual

The vision of His Royal Highness Prince Sultan Bin Salman Bin Abdul-Aziz Al Saud is that all people in the Kingdom of Saudi Arabia can fully participate and live independently in society, with access to public and private spaces for the purpose of education, employment, health, leisure and all other needs of daily living.

To achieve this vision, the Kingdom is embracing the evolving philosophy of universal accessibility, which promotes the concept of designing for all people.

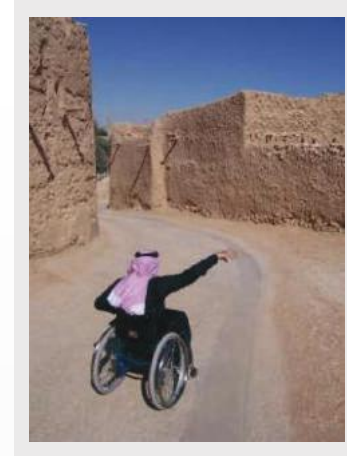

This Manual outlines the technical design requirements necessary to achieve universally accessible built environments across the Kingdom of Saudi Arabia. Architects, Engineers, interior designers, urban planners and others involved in the design of the built environment can use these guidelines for project development, resulting in creation of buildings and other built-environments that accommodate all members of Saudi society – including people with disabilities and older persons.

1.2 Context

The Universally Accessible Built Environment Guidelines Manual has been developed as part of a larger accessibility initiative within the Kingdom of Saudi Arabia:

In 2007, the Prince Salman Center for Disability Research engaged an international consortium of universal accessibility experts to undertake a review of the current status of accessibility for people with disabilities within the Kingdom, related to three focus areas: the Built Environment; Transportation; and Tourism. More specifically, the international experts reviewed existing Saudi legislation, policies, codes and standards and prepared a strategy for implementing universal accessibility across the Kingdom.

A critical component of the universal accessibility implementation strategy is the provision of appropriate technical information to the legislators, Ministries, architects, engineers and other designers that will be responsible for developing projects that address the needs of all Saudis. This Universal Accessibility Built Environment Guidelines Manual provides technical design guidelines and application criteria as a benchmark for the creation of universally accessible buildings and other built-environments.



A second Manual is also available titled, Universal Accessibility Land Transportation Guidelines Manual, which provides technical design guidelines and application criteria as a benchmark for the creation of universally accessible transportation systems.

1.3 Scope

The Universally Accessible Built Environment Guidelines Manual addresses the universal accessibility of the built environment. The built environment is defined as:

Development within a building site including buildings and other man-made structures, as well as man-made exterior elements intended for human activity.

With the exceptions noted below, the Manual addresses universal accessibility of building and other built facilities within the following sectors: Government/Administrative, Health Care, Education, Religion, Commercial, Recreation and Residential.

Universal accessibility of the following types is not addressed by this Manual:

- A. Land transportation-related facilities including:
 - Land transport terminals including train terminals, subway/skytrain stations and bus terminals.
 - Bus stops and taxi stands
- B. Tourism-related facilities including:
 - Airports and ports
 - Ship and ferry terminals
 - Convention centres
 - Hotels
 - Tourism sites (heritage, historical, contemporary sites) and trails
- C. Access for people with disabilities within individual dwelling units

Note: The accessibility of land transportation facilities and elements are addressed by the Universal Accessibility Land Transportation Guidelines Manual – a partner document to this Manual.



The Universal Accessibility Built Environment Guidelines are intended to apply to all newly constructed and renovated facilities within the Kingdom of Saudi Arabia with the exception of Factory Uses (Group F Classification from the International Building Code) and High Hazard Uses (Group H Classification from the International Building Code).

General exceptions to the application of these Guidelines: the following areas and spaces are not expected to comply with these Guidelines or be on an accessible route.

- **Construction sites:** Structures and sites directly associated with the actual processes of construction, including but not limited to, scaffolding, bridging, materials hoists, materials storage, and construction trailers. Portable toilet units provided for use exclusively by construction personnel on a construction site.
- **Raised areas:** Areas that are raised primarily for purposes of security, life safety, or fire safety, including but not limited to, observation or lookout galleries, prison guard towers, fire towers, or life guard stands.
- **Limited access spaces:** Spaces accessed only by ladders, catwalks, crawl spaces, or very narrow passageways.
- **Machinery spaces:** Spaces frequented only by service personnel for maintenance, repair, or occasional monitoring of equipment. Machinery spaces include, but are not limited to, lift pits or lift penthouses; mechanical, electrical or communications equipment rooms; piping or equipment catwalks; water or sewage treatment pump rooms and stations; electric substations and transformer vaults; and highway and tunnel utility facilities.
- **Single occupant structures:** Single occupant structures accessed only by passageways below grade or elevated above standard kerb height, including but not limited to, toll booths that are accessed only by underground tunnels. Residential facilities (except for visitability requirements, as stated in 3.5.9.)
- **Raised Employee work areas :** Employee work areas, or portions of employee work areas, that are less than 30 square meters and elevated 180 mm or more above the finish floor or ground where the elevation is essential to the function of the space.
- **Raised refereeing, judging and scoring areas**
- **Raised structures used solely for refereeing, judging, or scoring a sport.**
- **Water slides**
- **Animal containment areas that are not for public use**
- **Raised diving boards and diving platforms**



1.4 How to Use the Manual

The Guidelines in this manual are prescriptive rather than performance-based. They have been developed with consideration of current conditions and the unique cultural and administrative characteristics of the Kingdom of Saudi Arabia.

Users of the Manual are encouraged to familiarize themselves with the concept of Universal Accessibility as outlined in Section 2.1, as well as the overall structure and organization of the Manual. This will give the reader an overview of the principal concepts and comprehensiveness of the technical design requirements for universally accessible buildings.

The Manual can also be used as a reference throughout the design process. Designers are encouraged to review the application requirements at an early stage of the design process to ensure their designs reflect the universal design philosophy. Thereafter, the detailed technical requirements can be used throughout the design development process. The checklists in Appendix H will facilitate this process.

The Universal Accessibility Built Environment Guidelines Manual is organized as follows:

Section 1.0 provides an overview of the purpose of the Manual, as well as the context and scope of the design guidelines.

Concepts of Universal Design and Universal Accessibility are introduced in Section 2.0. Human space and reach dimensions are also included in Section 2.0, providing anthropometric criteria for various users of the built environment including people using prams and strollers, people using crutches, walkers and canes, as well as people using manual wheelchairs, power wheelchairs and mobility scooters.

The design guidelines are organized in Section 3.0 as follows:

3.1 Exterior Elements

Design guidelines for elements that are typical to exterior horizontal and vertical pedestrian circulation systems are presented in this section. Elements covered in this section include parking, pedestrian crossings, landscaping and street furniture.

3.2 Interior Elements

Design guidelines for elements that are typical to interior horizontal and vertical circulation systems are presented in this section; In addition, bathroom & ablution facilities for private and public use, kitchen facilities and common work spaces are also presented in this section. Elements related to interior circulation systems include



entrances, lifts, moving walks, doors and glazing. Elements related to bathroom & cleansing facilities include ablution spaces, toilet stalls, toilet rooms, bathroom accessories, bathing & dressing spaces. Elements related to kitchens and common work spaces include counters, storage, sinks, appliances and equipment.

3.3 Amenities

Design guidelines for supplementary elements that may form a part of either interior or exterior access routes, depending on site and/or facility need and use, are presented in this section. Elements included in the section are waiting & queuing areas, viewing spaces, raised platforms, rest areas, drinking fountains and vending/ticketing machines.

3.4 Communication and Safety Systems

Design guidelines for building & site elements and systems that relate to occupant safety, security and communication are presented in this section. Examples of elements included in this section are emergency exiting, alarms, telephones, signage and detectable warning surfaces.

3.5 Building-Specific Requirements

Design guidelines that are related to specific site & building uses, are presented in this section. The guidelines in this section are in addition to those required in Section B.3.1 to B.3.4. Examples of facility types that are included in this section are mosques, swimming pools, libraries and police stations.

The Manual is concluded with eight Appendices as follows:

Appendix A

Glossary and definitions: Lists in alphabetical order many of the common terms that are used throughout this document.

Appendix B

Additional Design Considerations: This appendix incorporates additional design criteria for accessibility-related characteristics including Glare and Light Sources, Illumination, Materials and Finishes, Texture and Color, and Acoustics.

Appendix C

International Access Symbols: Provides examples of common International Access Symbols, as developed by the International Standards Organization (ISO).



Appendix D:

List of Abbreviations: Lists and defines abbreviations and acronyms used throughout the Manual.

Appendix E

References: Provides a list of bibliographic sources referenced in the development of this publication.

Appendix F

Subject Index: Provides an index of pages referencing a particular topic or keyword.

Appendix G

Universal Accessibility Built Environment Checklists: Contains checklists for the UABE Guidelines, as listed in the Table of Contents. Checklists are provided for both Exterior Environments and Interior Environments. Note that that these checklists are subject to on-site verification across KSA. Users are encouraged to provide comments and suggestions to the PSCDR using the Feedback Form in Appendix H to facilitate efforts to validate, refine and further develop the UABE Guidelines for KSA.

Appendix H

Feedback Form: Provides a form, that may be reproduced, and that enables individuals to provide their suggestions and comments to the Prince Salman Centre for Disability Research. This will greatly facilitate with future efforts to validate, refine and develop the Universal Accessibility Built Environment Guidelines.



2.0 UNIVERSALLY ACCESSIBLE BUILT ENVIRONMENTS





2.1 Basic Concepts

- Unless otherwise noted, dimensions are in millimetres.
- Unless otherwise noted, photographs and diagrams are by UDA and Associates.

Concepts of Universal Accessibility have evolved from the philosophy of Universal Design, which has its origins in Europe and North America, but is now a global approach to design, development, management and operation in environments and systems.

Universal Design (UD) is a rapidly evolving design philosophy that has its roots in the barrier free design movement of the 1980's and 1990's. Whereas the focus of barrier free design was exclusively on providing appropriate facilities for people with disabilities, Universal Design takes a much broader approach based upon accommodating the diversity of human characteristics within the population as a whole.

Universal Accessibility accepts the reality that the broader population comprises of people with a wide range of ages, heights, weights, language skills and abilities. It encourages designers to recognize such diversity within the creative design and planning process, resulting in buildings and products that are more accommodating and functional for all users – including people who are disabled or elderly.

The interaction between people, throughout their life cycles and the environment in which they live, is dynamic; it is in a state of constant change. Universal Accessibility recognizes this changing dynamic, and requires designers to plan for it. Consider the design impact of:

1. Differing dimensional and ability characteristics of children from various age groups;
2. The changes in ability that come with ageing;
3. The change of size, flexibility and stamina that come with pregnancy;
4. The varying language and comprehension skills of visitors to religious sites such as Mecca or Medina;
5. The consequences of disease;
6. The consequences of trauma or conflict; and
7. The shift in patterns of economic activity - the change from a manufacture economy to a service economy.

A Universally Accessible facility will accommodate such diverse groups; appropriately, safely and with dignity, as well as optimising their functionality within the systems and environments in which they operate.



Universal Accessibility is achieved through integrating the philosophy of Universal Design into the creative process. The concept of Universal Design was formally defined in 1997 by the North Carolina Centre for Universal Design and is defined as;

“The design of products and environments to be useable by all people, to the greatest extent possible, without the need for adaptation or specialized design.”

Universal Design challenges designers to maximize the usability and marketability of their creations through recognizing the diversity of end users. The socially conscious universal philosophy promotes an inclusive approach to design, considering the needs of all users, regardless of age or ability.

Universal Design is applicable to any sector of the design community and is based on seven design principles;

1. Equitable Use.
2. Flexibility of Use
3. Simple and Intuitive Use
4. Perceptible Information
5. Tolerance for Error
6. Low Physical Effort
7. Size and Space for Approach and Use

The concept of Universal Accessibility therefore encompasses much more than dimensional requirements for design. It requires that Urban Designers, Architects, Interior Designers, Building Providers, Building Managers, Transportation Planners, Tourism Operators, etc., working in both the public and private sector, develop an understanding of the diversity of human characteristics and ability, as well as an appreciation for the challenges that many people encounter when negotiating urban and rural spaces, or the difficulty they experience when using a building, transportation system, or tourism site.

The incorporation of Universal Accessibility into current and future development within the Kingdom will ensure that virtually all Saudi's will have access to social structures, and can contribute to them without hindrance. It will facilitate access for the greatest number of people possible - ensuring that participation of people in Saudi society is not being handicapped by inaccessible environments and systems.



2.2 Anthropometric Data

2.2.1 Design Considerations

The spatial requirements and movement profiles of people using wheelchairs, mobility scooters and other mobility devices, as well as people with luggage, prams or strollers are, as varied as the individuals themselves.

Traditional approaches to accessibility have been conservative in nature, catering to the needs of physically strong individuals using manual wheelchairs – which is an exceptionally narrow characterisation.

True universal accessibility should address the needs of all users, including those with limited strength, those using larger mobility devices, as well as others who other wheeled mobility devices such as prams, strollers and wheeled-luggage.

This manual aims to more accurately reflect the vast array of equipment that is used by people to access and use facilities, as well as, the diverse range of user ability. Emphasis is placed on appropriate space allowances that accommodate the dynamic movements of people using wheelchairs, mobility scooters, or other assistive devices.

2.2.2 Application Guidelines

Space and reach requirements for people who use wheelchairs, mobility scooters, and other wheeled mobility devices, should comply with this section.

2.2.3 Technical Guidelines

a. General: All pedestrian access routes and areas should provide sufficient space to accommodate all people.

b. Clear Floor Space: *Figure 2* outlines the minimum requirements for clear floor space or ground space.



Figure 2: Clear Floor Space Requirements

User Type	Clear Floor Space Requirements	Reference
Person with a pram or stroller	Clear floor area at least 1650 mm long and 650 mm wide	Figure 3
Person with luggage	Clear floor area at least 1500 mm long and 700 mm wide	Figure 4
Person using crutches	Clear floor area 810-920 mm wide	Figure 5
Person using a walker	Clear floor area at least 710 mm wide	Figure 6
Person using a long cane	Clear floor area 900-1500 mm wide	Figure 7
Person using a manual wheelchair	Clear floor area at least 1300 mm long and 800 mm wide	Figure 8
Person using a power wheelchair	Clear floor area at least 1360 mm long and 800 mm wide	Figure 9
Person using a mobility scooter	Clear floor area at least 1400 mm long and 800 mm wide	Figure 10

Access to building elements for users of wheelchair or mobility scooters may be provided through by either a forward or parallel approach.

The knee space required under some objects may be incorporated into the clear floor space or ground space requirements.

Clear floor space for a wheelchairs or mobility scooters should either adjoin or overlap an accessible route, or be immediately adjacent to another wheelchair or mobility scooter space.

Additional manoeuvring clearances should be provided as shown in Figures 15-18 for clear floor space that is located in an alcove or otherwise confined on all or part of three sides.

c. 360 and 180 Degree Turn: 2100 mm in diameter of clear floor space is required for most wheelchairs and mobility scooters to make a 180 or 360-degree turn (*Figure 11*).

d. 3-Point Turn: A T-shaped space as shown in (*Figure 12*), is required for most wheelchairs and mobility scooters to make a 3-point turn.

e. Side Reach: The maximum high side reach for a parallel approach should be 1350 mm, and the minimum low side reach no lower than 250 mm above the floor (*Figure 17*). If the side reach is over an obstruction, all clearances should be as shown in *Figures 18 and 19*.



f. Forward Reach: The maximum high forward reach for a forward approach shall be 1200 mm, and the minimum low reach shall no lower than 450 mm above the floor (Figure 20). If the forward reach is over an obstruction, clearances should be as shown in Figures 21 and 22.

g. Knee Space, Toe Clearance and Lap Space for Seated People: A clear knee space at least 685 mm high and 280 mm deep should be provided, as well as a further clear toe space at least 300 mm high and 250 mm deep (Figure 24). Lap clearance should be at least 700 mm high and 600 mm deep (Figure 25).

2.2.4 Illustrations



Figure 3: Clear Floor Space for a Person with a Typical Pram/ Stroller (see Figures 26-31 for additional configura

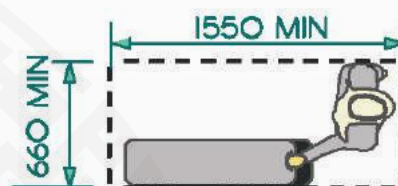

Figure 4: Clear Floor Space for a Person with Luggage



Figure 5: Clear Floor Space for a Person using Crutches



Figure 6: Clear Floor Space for a Person using a Walker

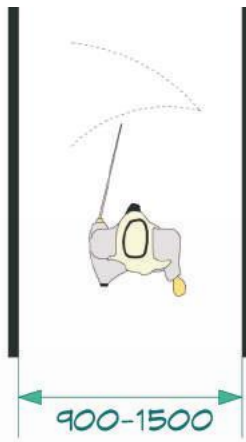

Figure 7: Clear Floor Space for a Person using a Long White Cane

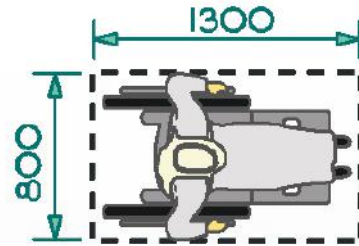

Figure 8: Clear Floor Space for a Person using a Manual Wheelchair

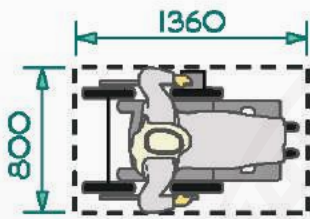

Figure 9: Clear Floor Space for a Person using a Power Wheelchair

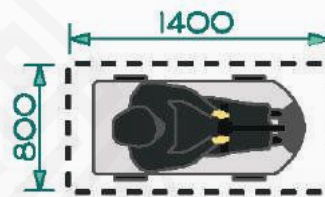

Figure 10: Clear Floor Space for a Person using a Mobility Scooter

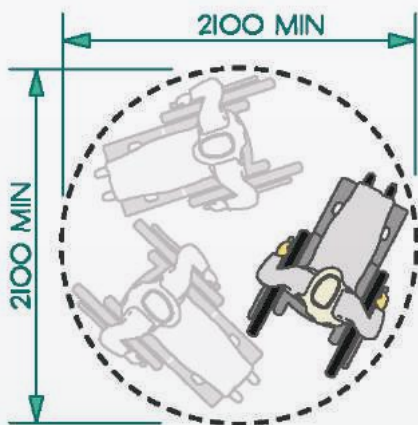

Figure 11: 360° Turning Space for Wheelchair

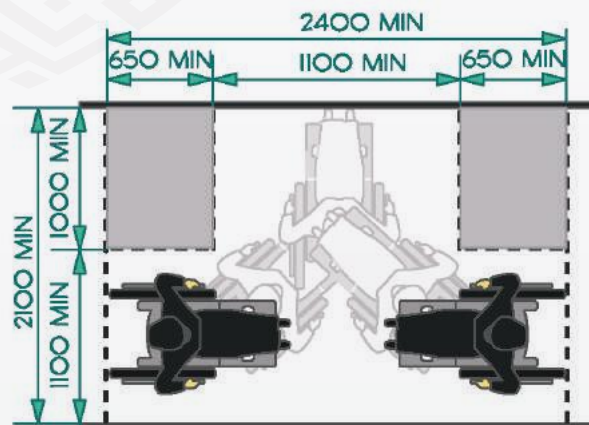
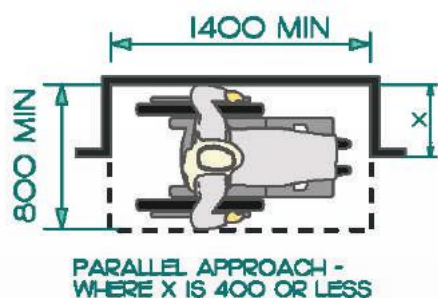
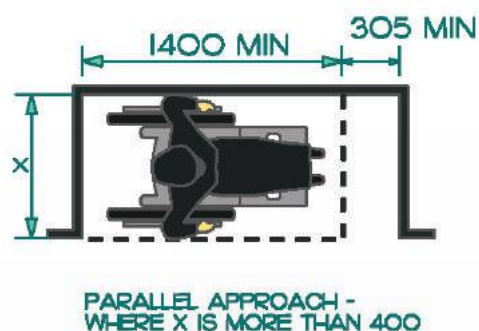

Figure 12: 3-Point Turning Space for Wheelchair or Mobility Scooter



PARALLEL APPROACH -
WHERE X IS 400 OR LESS

Figure 13: Clearances at Alcove



PARALLEL APPROACH -
WHERE X IS MORE THAN 400

Figure 14: Clearances at Alcove

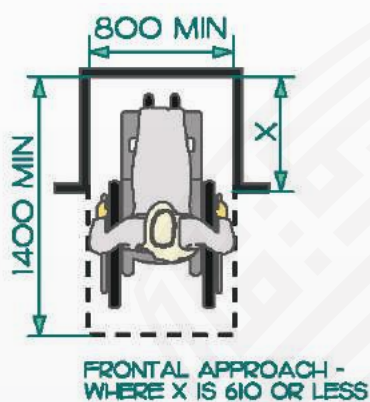

FRONTAL APPROACH -
WHERE X IS 610 OR LESS

Figure 15: Clearances at Alcove

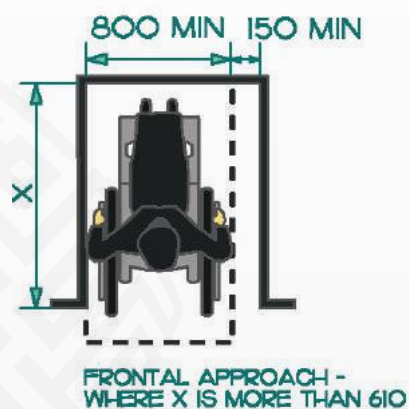

FRONTAL APPROACH -
WHERE X IS MORE THAN 610

Figure 16: Clearances at Alcove

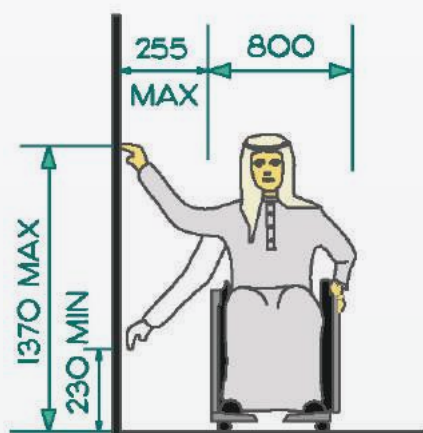

Figure 17: Side Reach

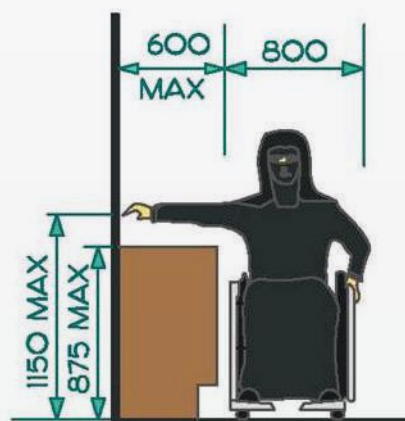

Figure 18: Side Reach over an Obstruction

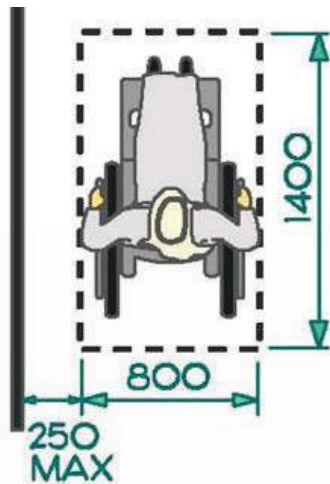

Figure 19: Side Reach - Maximum
Distance to Wheelchair

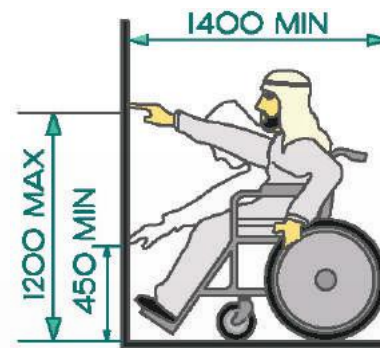

Figure 20: Forward Reach

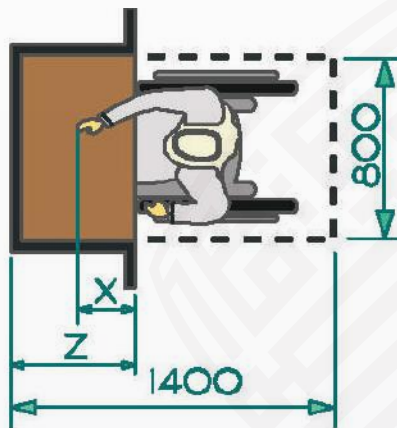

Figure 21: Forward Reach over an
Obstruction

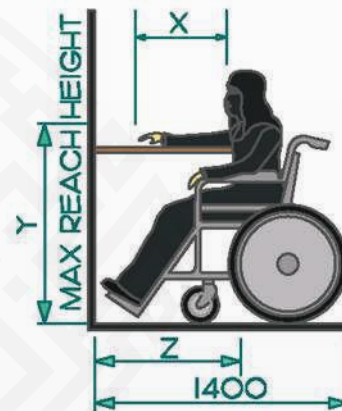

Figure 22: Forward Reach over an
Obstruction

Note: In Figures 21 and 22

- X should be less than or equal to 625 mm: Z should be greater than or equal to X.
- When X is less than 500 mm, then Y should be 1200 mm maximum
- When X is 500 to 625 mm, then Y should be 1100 mm maximum

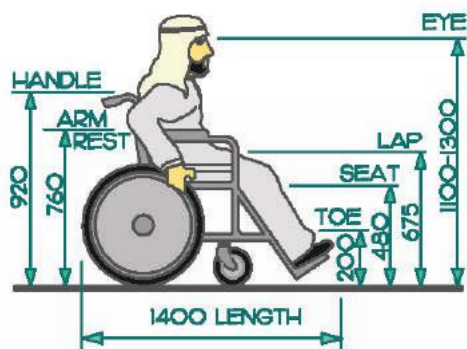

Figure 23: Typical Dimensions of an Adult Manual Wheelchair

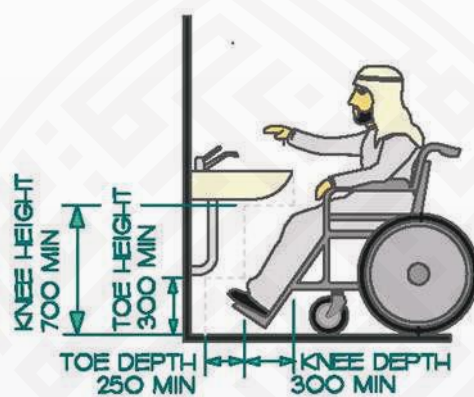

Figure 24: Knee and Toe Clearances

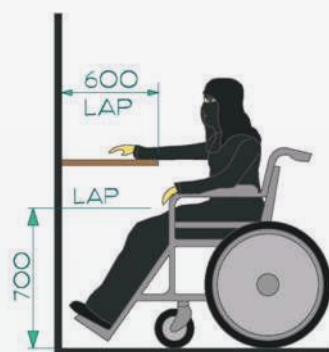

Figure 24: Knee and Toe Clearances

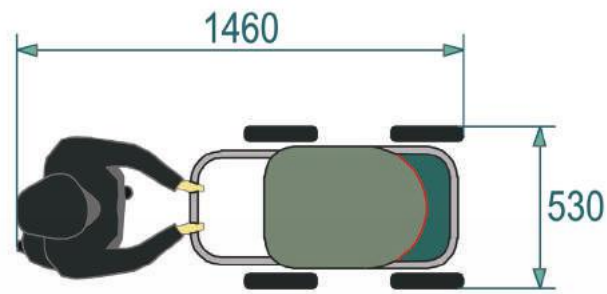

Figure 26: Clear Floor Space for a Single Regular Stroller

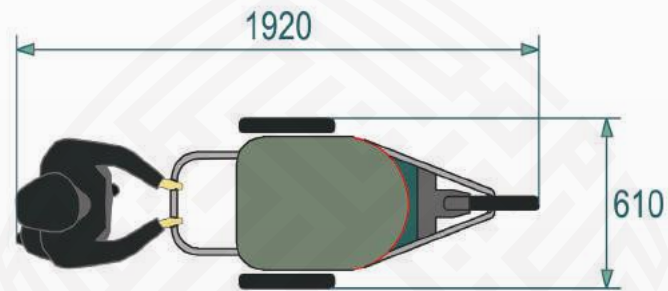

Figure 27: Clear Floor Space for a Single Jogger Stroller

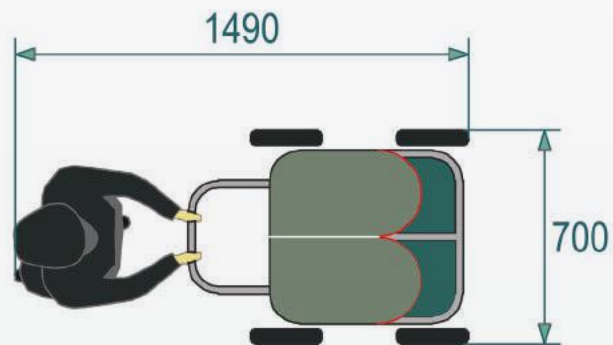

Figure 28: Clear Floor Space for a Twin Side-by-Side Stroller

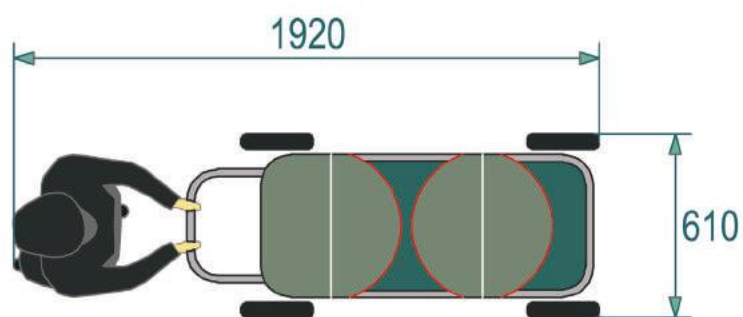

Figure 29: Clear Floor Space for a Twin Tandem Stroller

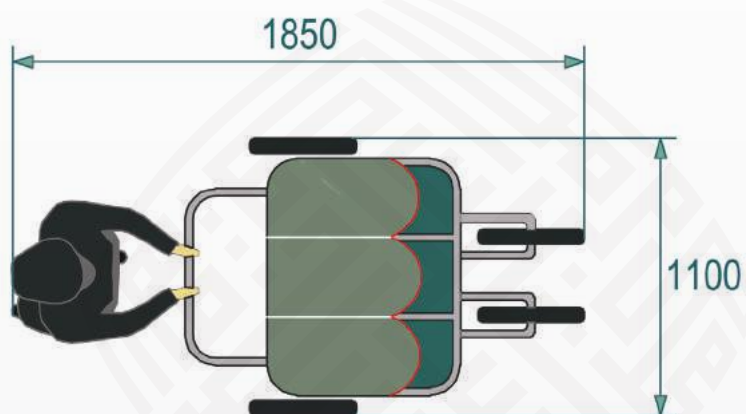

Figure 30: Clear Floor Space for a Triple Side-by-Side Stroller

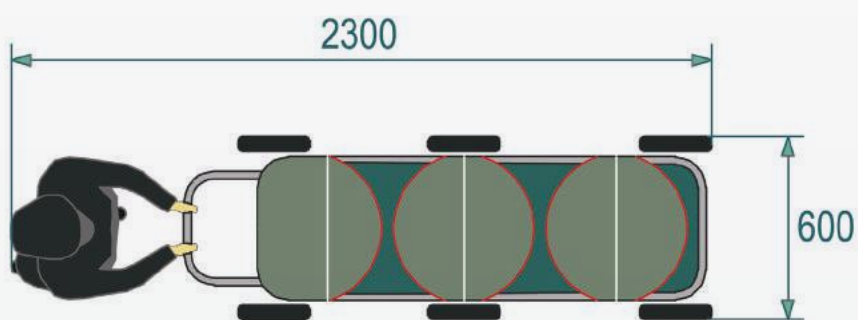

Figure 31: Clear Floor Space for a Triple Tandem Stroller



UABE TECHNICAL & DESIGN GUIDELINES

3.1 Exterior Elements





The Prince Salman Center for Disability Research would like to acknowledge the groundbreaking work undertaken by City of London (Ontario, Canada) in the development of their 2001 and 2007 Facility Accessibility Design Standards (FADS), as well as the City of Winnipeg (Manitoba, Canada) for their 2006 Winnipeg Accessibility Design Standards.

These documents were instrumental in advancing and codifying concepts of universal accessibility, and were a significant part of the inspiration for the KSA Universal Accessibility Built Environment Guidelines.



3.1 EXTERIOR ELEMENTS

3.1.1 Ground Surfaces

3.1.1.1 Design Considerations

The selection of an outdoor ground surface should consider the needs of all potential users into account. The use of irregular surfaces, such as cobblestones, pea-gravel walkways, or pea-gravel finished concrete, can be challenging to people who are using wheelchairs or those individuals who have difficulty walking. Slippery surfaces are hazardous to all individuals, but especially to seniors and those without sure-footing. An unexpected slip or fall can result in serious injury. Unmarked openings in the ground, such as grates or grilles, can catch canes or wheels, while small and uneven changes in the ground level hinder wheelchair use and present tripping hazards for ambulatory persons.



Figure 32: Ground and Floor Surfaces



Figure 33: Ground and Floor Surfaces

Showing stable, firm, glare-free and slip-resistant surfaces.

3.1.1.2 Application Guidelines

Exterior ground surfaces used in areas and routes frequented by staff and the public should comply with this section.



3.1.1.3 Technical Guidelines

a. Ground Surfaces: Ground surfaces should be stable, firm, slip-resistant, and produce no glare. Excessive use of floor patterns that are counter-intuitive to the use and movement within the accessible space, or along the accessible route, should be avoided.

b. Changes in Level: Except for lifts and other elevating devices which should comply with Sections 3.2.5 through 3.2.8, changes in level should comply with *Figures 34, 35 and 36*.

Further requirements apply to other elements as follows: Ramps (Section 3.1.4), Stairs (Section, 3.1.5), Kerb Cuts (Section 3.1.6).

Vertical Rise	Vertical Rise
Up to 6 mm(Figure 35)	No treatment required. i.e. edge may be vertical
Between 7 mm and 13 mm (Figure 36)	Bevelled edge is required; no steeper than a 1:2 ratio. i.e.(50% slope)
Over 13 mm	Not steeper than the ratio of 1:16 (6.25%) & treated as a sloped floor, ramp or kerb cut

Figure 34: Changes in Level

c. Gratings: Openings in gratings should not exceed 13 mm in width in at least one of its axis. Gratings should be placed so that the longest dimension of the opening is perpendicular to the dominant direction of travel. (*Figure 37*)

d. Pavers: Joints between pavers with squared edges at the walking surface should be no greater than 6 mm. Pavers with bevelled edges at the walking surface should have a maximum spacing of 13 mm between the top edges of adjacent bevels.

e. Catch Basins or Drainage Inlets: Catch basins or drainage inlets should not be located in the accessible route and should be relocated if already existing in an accessible route. If relocation of an existing catch basin or drainage inlet is technically infeasible, the basin and inlet covers should comply with clause (c).



3.1.1.4 Illustrations



Figure 35: Changes in Level up to 6 mm

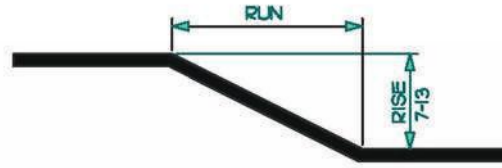

Figure 36: Changes in Level between 7 and 13 mm



Figure 37: Grills and Gratings

3.1.1.5 Other Considerations

- 3.1.3 Sidewalks, Pavements, Paths and Routes
- 3.4.6 Detectable Warning Surfaces

- Appendix B Materials and Finishes
- Appendix B Texture and Color



3.1.2 Overhead and Protruding Objects

3.1.2.1 Design Considerations

Overhead and protruding objects along pedestrian routes and in private and public utilised spaces are hazardous to both sighted and non-sighted people. These areas should be free of protruding objects or freestanding obstacles for the safety of all users. Commonly found design elements positioned above the detection range of a long white cane, such as an overhanging tree branch or a drinking fountain, pose potential threat of injury. Likewise, protruding objects at low levels also present tripping and injury hazards where they cannot be detected. All freestanding obstacles, such as light standards or trees, require warning surfaces to alert all pedestrians to their presence.



Figure 38: Detectable Barrier

Detectable barrier guards area below



Figure 39: Detectable Handrail

*Handrail extensions are cane detectable.
stairs where headroom is low*

3.1.2.2 Application Guidelines

Protruding and overhanging objects including free-standing, wall-mounted and ceiling-mounted objects, should comply with this section.

3.1.2.3 Technical Guidelines

a. Protruding Objects: The leading edge of any protruding object found between 650-2100 mm above the ground should not extend more than 100 mm into pedestrian areas. An object with a leading edge at or below 650 mm from the ground may protrude any distance. *(Figures 40 and 41)*



b. Freestanding Objects: Where overhanging or protruding elements on freestanding objects are between 650-2100 mm above the ground, they should not encroach more than 300 mm into pedestrian areas. The bottom edge of a freestanding object, with a space of more than 300 mm between supports, should not be more than 650 mm above the ground.

c. Width Maintenance: The width of manoeuvring spaces or accessible routes should not be reduced by protruding objects.

d. Headroom: The clear height for headroom in pedestrian areas should be a minimum of 2100 mm above the floor. A doorway clear height of 2100 mm is preferred; however a clear height of 1980 mm at the door is acceptable. (*Figure 42*)

e. Overhead Hazard: Where the headroom of an area that adjoins an accessible route is reduced to less than 2100 mm, a detectable guard, guardrail or other barrier with a leading edge at or below 650 mm above the floor should be provided. The guard should be firmly fixed, color contrasted & have solid or horizontal railings (*Figure 42*).

f. Detectable Ground Surface: A tactile and color contrasted warning surface, located flush with the surrounding walking surface and extending at least 300 mm outward around the entire overhead or protruding hazard, should be provided.

g. Color Contrast: The leading edge of a protruding or overhanging object should be color contrasted to its background and surroundings to enhance the visibility of the protruding and overhanging object.

h. Walkway Widths for People Using Crutches: Walkways utilised by people using crutches typically require 810-920 mm clear width. Where walkways are expected to be utilised by people using crutches, no obstructions or projections should be placed lower than 300 mm above the floor. (*Figure 5*)

i. Detection Space for People Using a Long White Cane: People who use a long white cane to help them manoeuvre, can detect an obstruction within a height range of up to 650 mm from the ground. Depending on the person, the forward detection range can vary from 900-1500 mm. (*Figure 7*)

j. Detection Space for People Using a Walker: The typical ground width dimension for a person using a walker is 710 mm. (*Figure 6*).



3.1.2.4 Illustrations



Figure 40: Limits of Protruding Objects

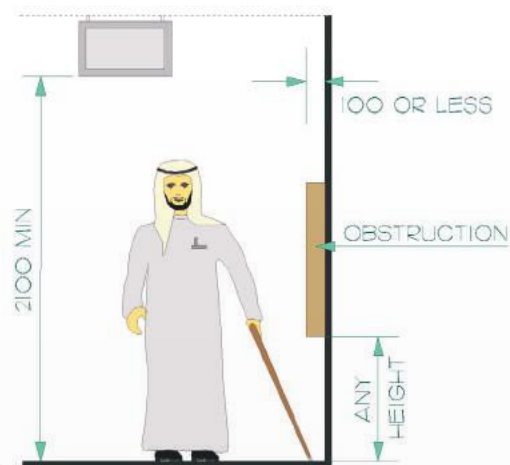

Figure 41: Limits of Protruding and Overhanging Objects

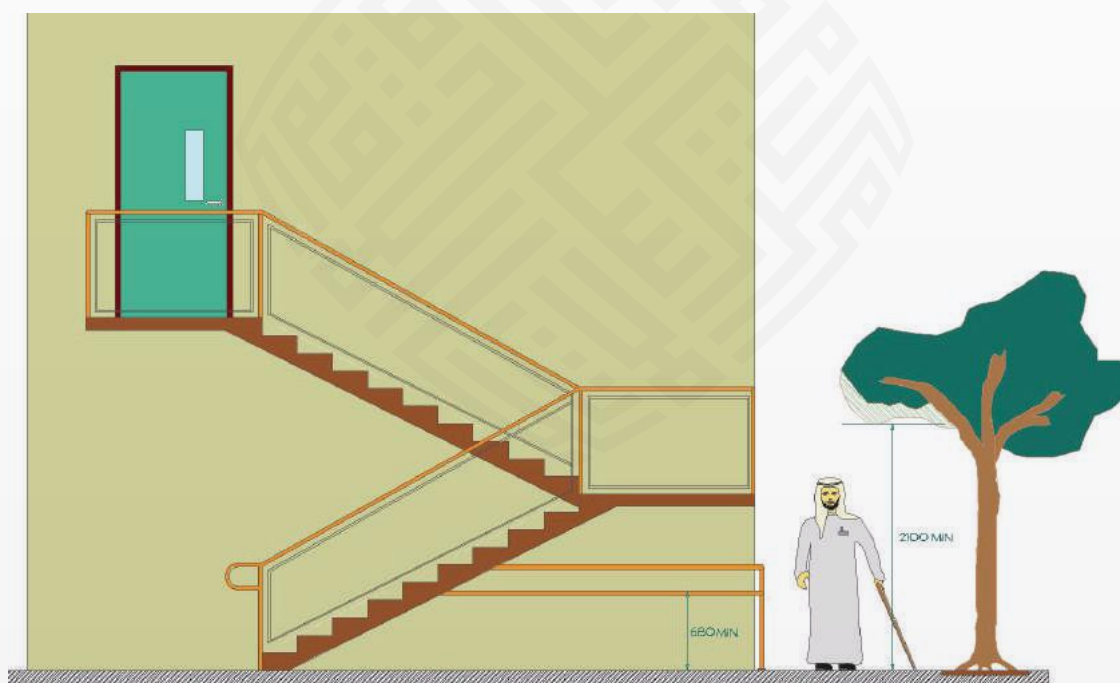

Figure 42: Overhead Obstructions

3.1.2.4. Other Considerations

3.1.3 Sidewalks, Pavements, Paths and Routes *Appendix B Materials and Finishes*

3.4.6 Detectable Warning Surfaces *Appendix B Texture and Color*



3.1.3 Sidewalks, Pavements, Paths and Routes

3.1.3.1 Design Considerations

The design of exterior travel routes should reflect an understanding of the way individuals will use them. An adequate sidewalk, pavement or path width provides space for people using wheelchairs, mobility scooters, those travelling in pairs, and those pushing strollers. The manoeuvrability of assistive devices should be considered in design plans; for example, while a sideway or path may be wide enough for a person to drive a mobility scooter in a straight line, it may not be possible to make a turn. The preferred minimum clear width for accessible routes is 1800 mm. Strong color contrasts and/or tactile surfaces are recommended to provide navigational cues to people with visual impairments. All changes in level should be clearly marked with edge protection.

3.1.3.2 Application Guidelines

All sidewalks, pavements, paths and routes intended for the use of general staff and the public should comply with this section.

Where a difference in elevation exists, accessible routes can include ramps, stairs, kerb cuts, lifts or other elevating devices (as permitted in Sections 3.1.4, 3.1.5, 3.1.6, 3.2.6 and 3.2.7).

3.1.3.3 Technical Guidelines

a. Clear Width: The clear width of accessible routes should be a minimum of 1200 mm. Where space is required for two wheelchairs to pass, the minimum clear width of the accessible route should be 1800 mm. (*Figure 46*)

b. Passing Places: When the clear width of an accessible route is 1800 mm or less, unobstructed passing spaces should be provided and should measure at least 1800 mm in width and 1800 mm in length and be spaced at no more than 30 metres apart.

c. Slope: The running slope of accessible routes should not exceed a 1:25 ratio (4% slope). The cross slope should be avoided but where necessary be no steeper than a 1:50 ratio (2% slope). Note: Accessible sidewalks, pavements, paths or routes with a slope steeper than a 1:25 ratio (4% slope), are classified as a ramp and are to be designed to comply with Section 3.1.4.

d. Kerb Cuts: Where kerb cuts are provided as part of an accessible route, they should comply with Section 3.1.6.



Figure 43: Accessible Exterior Route Photo
Source: City of Winnipeg



Figure 44: Accessible Exterior Route

Showing color contrasted, detectable paths along exterior routes.

e. Edges: If a change in level occurs between the edge(s) of an accessible route and an adjacent surface, and is between 200 mm to 600 mm above the ground, the edge(s) of the accessible route should be protected by a color contrasted kerb, or other material, that is at least 75 mm above the ground (Figure 45). If the change in level is greater than 600 mm, a guard that meets the requirements of the Kingdom of Saudi Arabia Building Code should be installed.

f. Edge Definition: Materials of contrasting color and texture should be used to define the edges of sidewalks, pavements, paths and routes.

g. Change of Direction Signage: Directional signage should be provided where there is a change in direction along an accessible route and the intended destination is not clearly visible, or is obstructed, from the change in direction location; Refer to Section 3.4.1.

h. Illumination: A minimum of 30 lux is required along exterior accessible routes, except in outdoor park settings where routes are not required to be illuminated. Refer to Sections 3.1.4, 3.1.5 and Appendix B for additional illumination guidelines for ramps and stairs.

i. Rest Areas: All sidewalks, pavements, paths and routes should include level rest areas spaced at no more than 50 metres apart. Refer to Section 3.3.7 for further requirements.

j. Surfaces: Wall surfaces along accessible routes should have non-abrasive surfaces. Highly reflective wall surfaces or wall and floor that produce high levels of glare should be avoided. Ground surfaces along access routes should not be heavily patterned or contain counter-intuitive patterning.

k. Landscaping: Landscaping along accessible routes should comply with Section



3.3.14.

3.1.3.4 Illustrations



Figure 45: Edge Protection

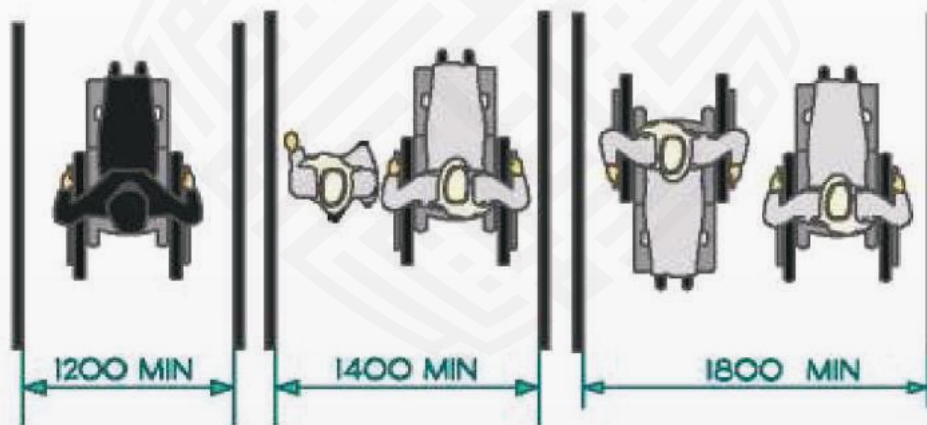

Figure 46: Access Widths

3.1.3.5 Other Considerations

3.1.1 Ground Surfaces

3.1.4 Ramps

3.1.6 Kerb Cuts

3.3.4 Raised Platforms and Stage

3.4.1 Signage

3.4.6 Detectable Warning Surfaces

3.1.12 Street Furniture

Appendix B Glare and Light Sources

Appendix B Illumination

Appendix B Materials and Finishes

Appendix B Texture and Color



3.1.4 Exterior Ramps

3.1.4.1 Design Considerations

Ramps, often traditionally synonymous with wheelchair accessibility, can be dangerous, problematic, and difficult to use if not designed properly. The space required for well designed ramps can make them challenging to integrate into a facility. Designs that minimize the need for ramps are preferred. Where a change in level already exists or cannot be avoided, a well designed ramp can provide access for those using wheelchairs, mobility scooters, moving packages on a trolley, or pushing strollers. The usefulness and safety of a ramp is determined by careful design. Ascending a steep ramp is difficult when using a wheelchair, and can increase the risk of the wheelchair tipping backwards. Descending a steep ramp can also be dangerous. Any cross slope should be avoided as it will increase the effort required to negotiate the ramp. Manoeuvring space at the top and bottom are important usability factors for a ramp. Providing level landing areas at intervals along a long ramp allow for brief rest areas for people with lower stamina. Important safety features include handrails, textured surfaces, and edge protection. Some people have difficulty using slopes so stairs should also be provided in where ramps are necessary.

3.1.4.2 Application Guidelines

Any part of an accessible sidewalk, pavement, path or route that has a running slope steeper than 1:25 (4% slope) is a ramp and should comply with this section. Where ramps are used, an adjacent set of stairs should also be considered.

3.1.4.3 Technical Guidelines

a. General: Accessible ramps should be located on accessible routes in compliance with Section 3.1.3.

b. Running Slope: The running slope of a ramp should be between 1:16-1:25. In a renovation situation, where it is technically infeasible to provide a ramp with a running slope between 1:16-1:25, and a running slope that does not exceed 1:12 may be used. (*Figure 47 and 48*)

c. Horizontal Length of a Ramp: The maximum horizontal length of a ramp, measured between ramp landings, should not exceed 9 meters. (*Figure 47*)

d. Cross Slope: Cross slopes should be avoided. Where they cannot be avoided, the maximum cross slope of ramp surfaces should be 1:50.



e. Ramp and Landing Surfaces: Ramp and landing surfaces should be firm, stable, and slip-resistant. Ramps and the approaching access routes should be designed so that water will not accumulate on walking surfaces.

f. Landing Slopes: Level landing areas should be provided at the top and bottom of all ramps and where the ramp changes direction. The maximum slope in any direction on a landing should be 1:50 to allow for proper drainage.

g. Landing Size at Top and Bottom: The top and bottom landings should be no less than 2100 x 2100 mm. In a renovation situation, where creating a suitably sized landing is technically infeasible, the required landing size may be reduced to 1800 x 1800 mm. (*Figure 47 and 48*)

h. Intermediate Landing Size: Intermediate landings at the switchback of a U-shaped ramp (180° turn), should be a minimum of 1800 mm deep and 2400 mm wide. Where an intermediate landing is located at the corner of an L-shaped ramp (90° turn), the depth and width of the landing should be a minimum of 1800 mm. Where an intermediate landing occurs on a straight ramp, the depth of the landing should a minimum of 1800 mm. (*Figure 47*)

i. Obstructions at Landings: Where windows or doors open across a ramp landing surface, they should not obstruct movement along the ramp or on the landing.

j. Curved Ramps: Curved ramps are difficult for wheelchair manoeuvring and should not be used as part of an accessible route.

k. Edge Protection: Edges of ramps and landings should be protected with a wall or a guard on either side of the ramp. (*Figure 50*)

l. Ramp and Landing Guards: Where a guard is provided on a ramp or ramp landing, it should comply with the requirements of the Kingdom of Saudi Arabia Building Code. In addition, there should be provided a kerb a minimum of 75 mm above the ramp surface on any side of the ramp where no solid enclosure or guard is provided, and either have railings or other barriers that extend to within 50 mm of the finished ramp or a kerb not less than 75 mm above the ramp surface. (*Figure 50*)

m. Ramp Handrails: Handrails should comply with Section 3.3.13. A ramp run that has a rise greater than 150 mm should have handrails located on both sides of the ramp that are mounted at a uniform height above the ramp floor. Handrails should be continuous around the inside edge of a U-shaped or L-shaped ramp. Handrail should extend horizontally at least 300 mm onto the top and bottom landings and then return to the wall, floor, or post (*Figure 49*). Both an upper and lower handrail should be provided on each side of the ramp, with the upper handrail located at 875-925 mm and the lower handrail located 600-750 mm above the ramp surface. A tactile indicator in the form of a domed button should be provided on the top of the handrail located 140-160 mm from the end of the handrail and before an intermediate landing to indicate an upcoming change in slope. Handrails should incorporate



a pronounced color contrast to differentiate them from the surrounding surfaces.

n. Distance between Handrails: The clear width between ramp handrails should be 950-1100 mm apart. On wide ramps, where intermediate handrails are required, the distance between at least one set of handrails should be 950-1100 mm and located adjacent to one side of the ramp.

o. Handrails in Aisle Ways for Fixed Seating: Where a ramp serves as an aisle way for fixed seating, such as in an exterior or open-air performance venue, a ramp handrail is only required on any non seating sides adjacent to the ramp.

p. Illumination: The full run of the ramp including all landings should be evenly illuminated to a minimum of 100 lux.

q. Detectable warning surfaces: A detectable warning surface should be provided at the top of each ramp run. It should begin 300 mm back from the start of the ramp run, be 900 deep, and extend across the full width of the ramp. The detectable warning surface should have color, texture, and resiliency contrasting from the surrounding surface and should comply with Section 3.4.8.

r. Color contrasting strips: Ramps should have a color contrasting strip 40-60 mm wide across the full width of the ramp at the top and bottom of the ramp and at landings where there is a change in slope.

s. Signage: Where a ramp that is not immediate obvious is provided as a part of an accessible route serving a building entrance, signage in compliance with Section 3.4.1 should be installed to indicate the location of the accessible ramp and the entrance.



3.1.4.4 Illustrations

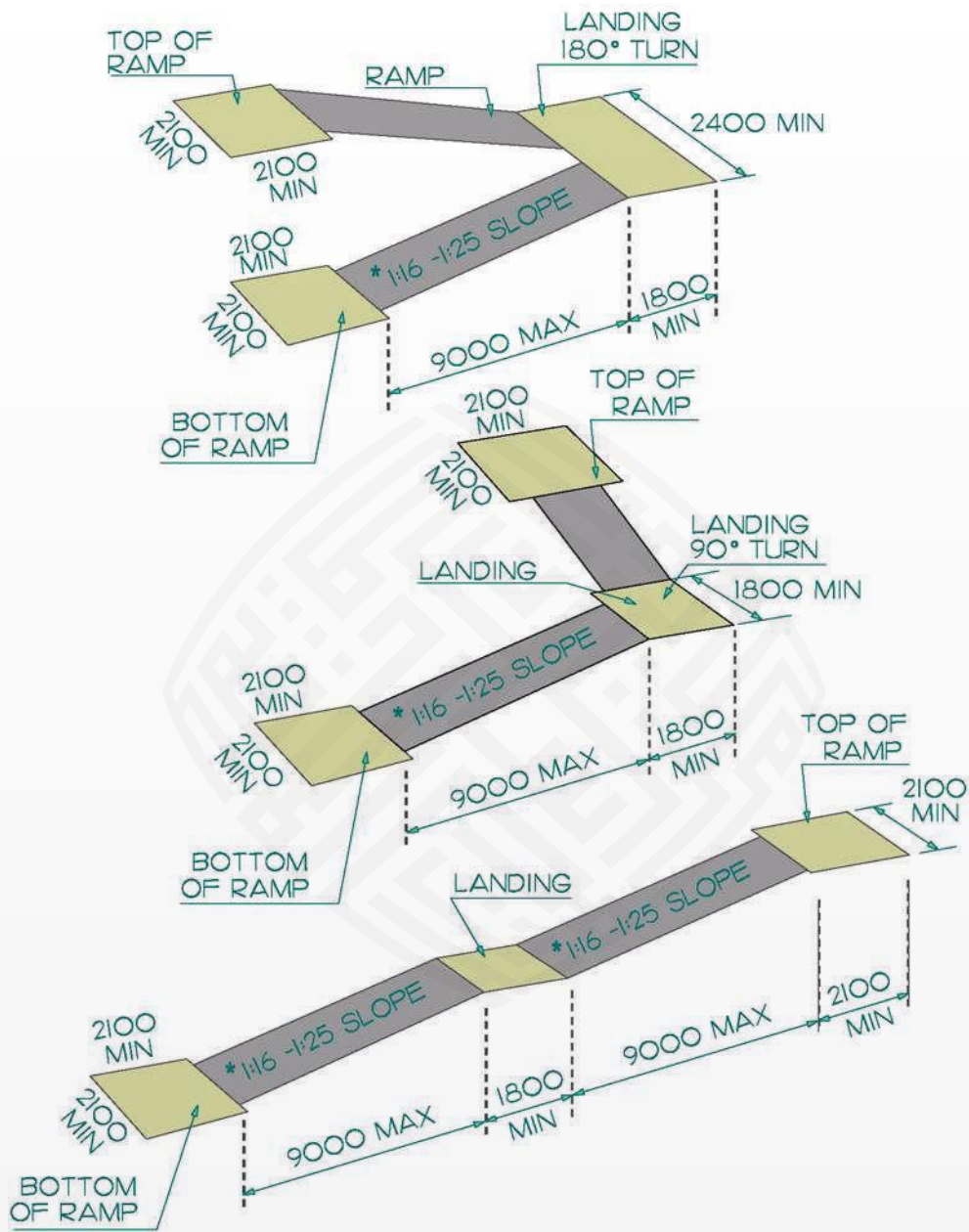

Figure 47: Minimum Ramp Landing Dimensions

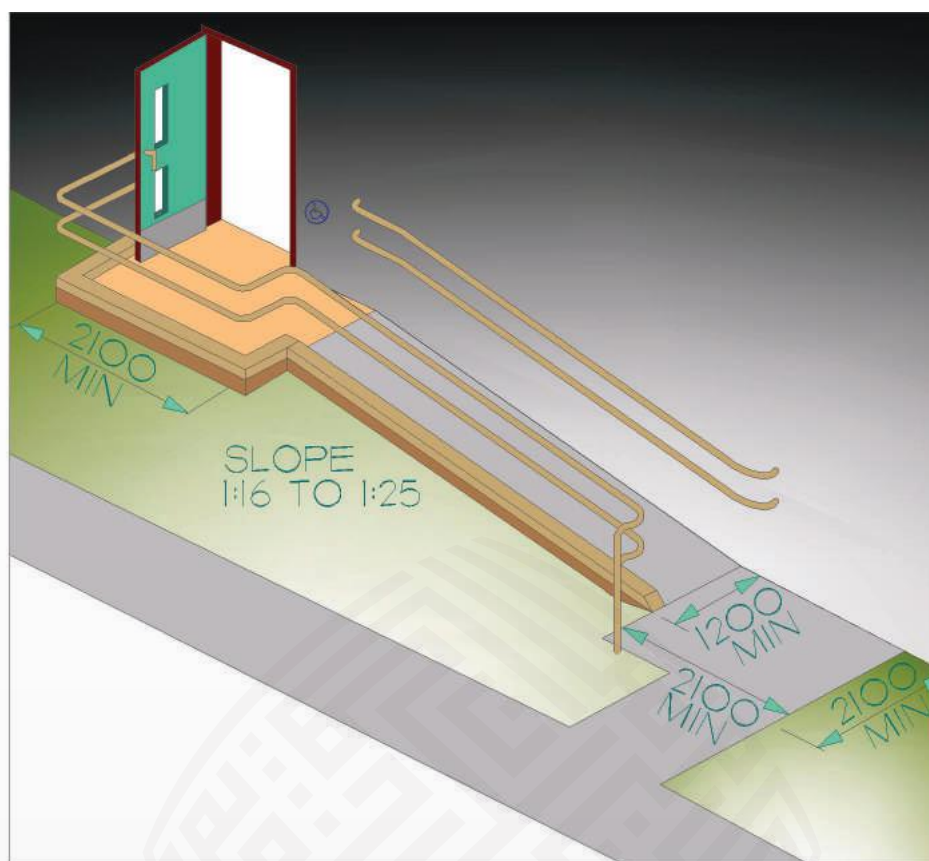

Figure 48: Ramp Criteria

Note: In a renovation where it is technically infeasible to provide a slope of 1:16 to 1:25, the maximum slope may be increased to 1:12.

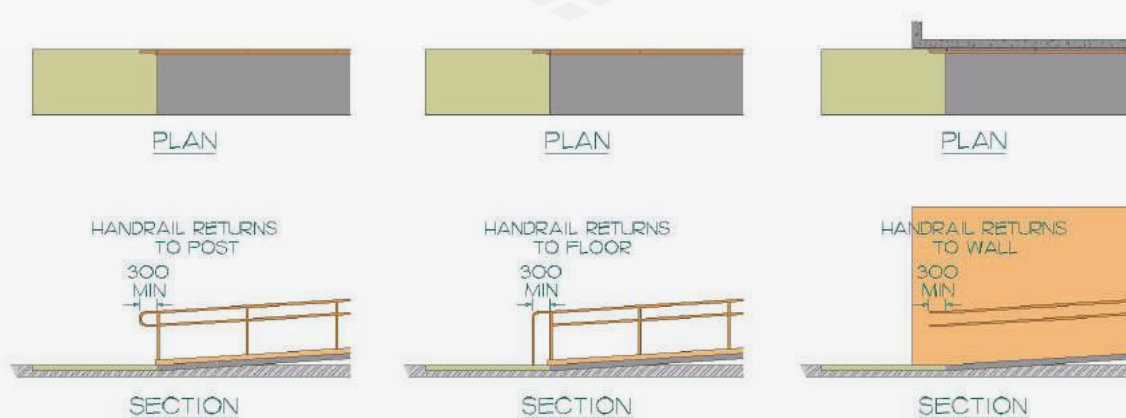
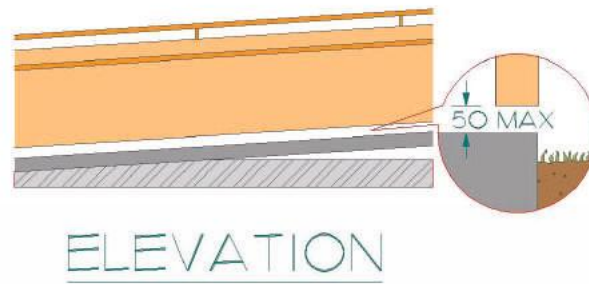
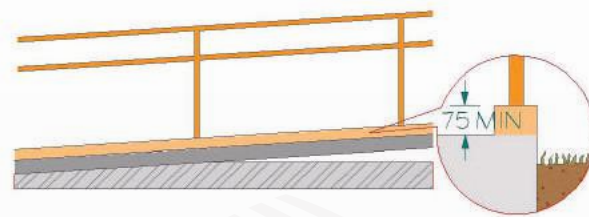

Figure 49: Horizontal Handrail Extensions



ELEVATION



ELEVATION

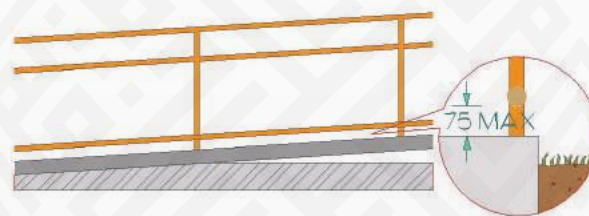

ELEVATION

Figure 50: Edge Protection at Ramps

3.1.4.5 Other Considerations

- | | |
|--|--------------------------------|
| 2.2 Anthropometric Data | 3.4.12 Glare and Light Sources |
| 3.1.1 Ground and Floor Surfaces | 3.4.13 Illumination |
| 3.1.9 Kerb cuts | 3.4.14 Materials and Finishes |
| 3.2.9 Doors | 3.4.15 Texture and Color |
| 3.3.13 Handrails | |
| 3.3.10 Controls & Operating Mechanisms | |
| 3.4.7 Signage | |
| 3.4.8 Detectable Warning Surfaces | |



3.1.5 Exterior Stairs

3.1.5.1 Design Considerations

Stairs can be challenging, especially to children, seniors, people with prosthetic devices or those using canes. Although poorly designed stairs are problematic for all individuals, they are especially hazardous to people who have trouble walking or difficulties with balance. Visual and tactile cues should be incorporated in stair design to warn people with a low or no vision that they are approaching a set of stairs – similarly, color contrast should be provided at stair nosings. In addition, the appropriate design of handrails is an important safety feature for all users.



Figure 51: Stair Configuration



Figure 52: Stair Configuration

Examples of a color contrast at stair nosing and detectable tactile strip at top and bottom of stairs.

3.1.5.2 Application Guidelines

Where new stairs are planned at exterior locations, they should comply with this section. Where existing stairs are to be renovated, the dimensions of existing steps and landings are not expected to comply with these guidelines - however all other design requirements should be met.

3.1.5.3 Technical Guidelines

a. Treads and Risers: Riser heights (rise) and tread depths (run) of stairs should be uniform. The rise should not exceed 180 mm high or be less than 125 mm high. The stair run, measured from riser to riser, should be no more than 350 mm deep and no less than 280 mm deep. Open risers should be avoided on stairs that are part of an accessible route. Stair treads and landings should be finished with non-slip material. (Figure 54)



b. Nosing: When stair nosings are incorporated in a stair design, they should project no more than 40-60 mm beyond the riser face, extend the full width of the tread, and be no more than 25 mm in height. Stair nosings should possess no abrupt underside and have a curved or bevelled leading edge with a 6-10 mm radius. Stair nosings should be sloped to the riser at an angle not less than 60 degrees to the horizontal. All stair treads, including nosings, should be illuminated with a minimum of 100 lux, use slip-resistant materials and make use of color contrast to differentiate between the horizontal and vertical surfaces. (*Figure 55*)

c. Detectable warning indicators: Stairs should incorporate detectable warning surfaces at the top and bottom of all stair flights. Detectable warning surfaces should extend the full width of the stair, have a depth of 600-900 mm commencing 300 mm from the edge of the stair, and comply with Section 3.4.6.

d. Stair Handrails: Dual height handrails should be installed on both sides of exterior stairs and be continuous along the inside edge of stairs that contain a switchback. The upper handrail should be located at a uniform height of 875-925 mm, measured vertically and directly above the stair nosing, and the lower handrail located at a uniform height of 600-750 mm also measured vertically and directly above the stair nosing. Handrails should extend past the top and bottom of all stair flights with the handrails at the bottom of stairs continuing a distance of one tread depth beyond the first riser, then horizontally for not less than 300 mm, at the applicable height required above the floor. Handrails at the top of stairs should continue horizontally for a distance not less than 300 mm, at the applicable height required above the floor. After extending at the top and bottom of stairs, handrails should then return to the wall or post in a way that does not impede or pose hazards to pedestrian travel. Where wide stairs are designed, intermediate handrail/s should be provided. Contrasting colors should be used to distinguish handrails from the surrounding environment and surfaces. In addition, handrails should comply with Section 3.3.13.

e. Illumination: Stairs and stair landings should be evenly illuminated to a minimum of 100 lux at exterior locations.

g. Headroom: In all cases, headroom over stairs should be a minimum of 2100 mm measured vertically from the leading edge of the stair nosing.

h. Windows and Doors: Windows and doors may open onto a stair landing provided they do not obstruct circulation or subtract from required clear widths.

i. Circular Stairs: Circular stairs are not considered to be part of an accessible route and should be avoided.

k. Patterned Surfaces: Surfaces containing a large degree of patterning or counter-intuitive patterning can cause disorientation and confusion, and should be avoided around stairs.



3.1.5.4 Illustrations

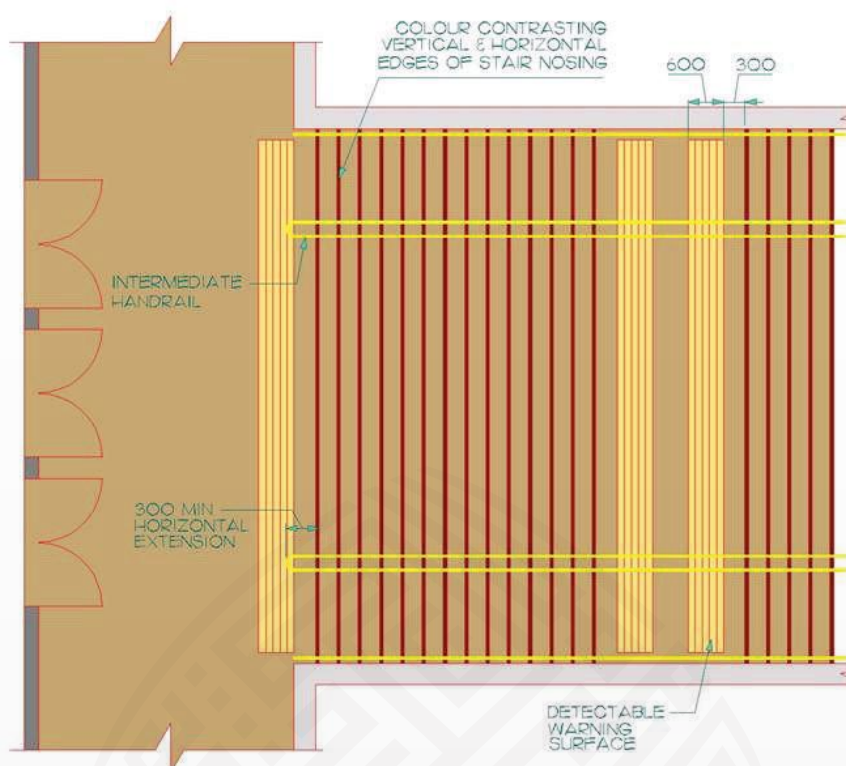

Figure 53: Stair Design Criteria

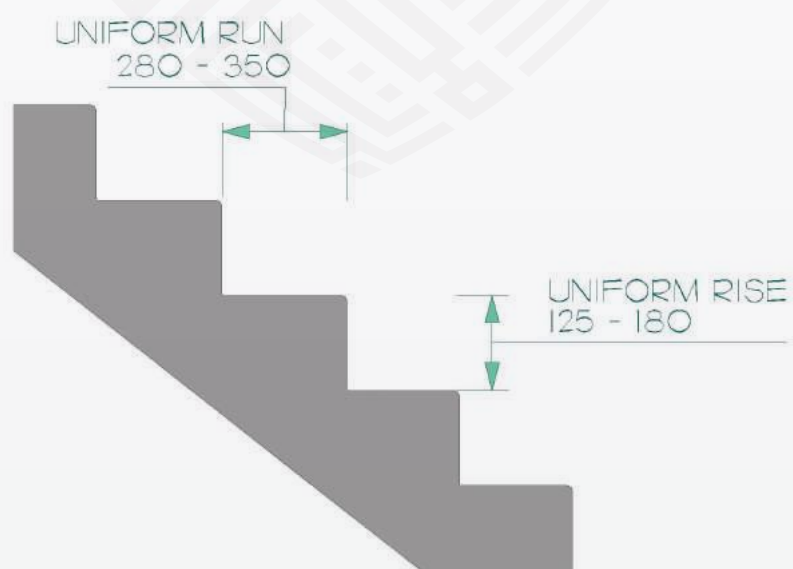

Figure 54: Stair Tread Criteria

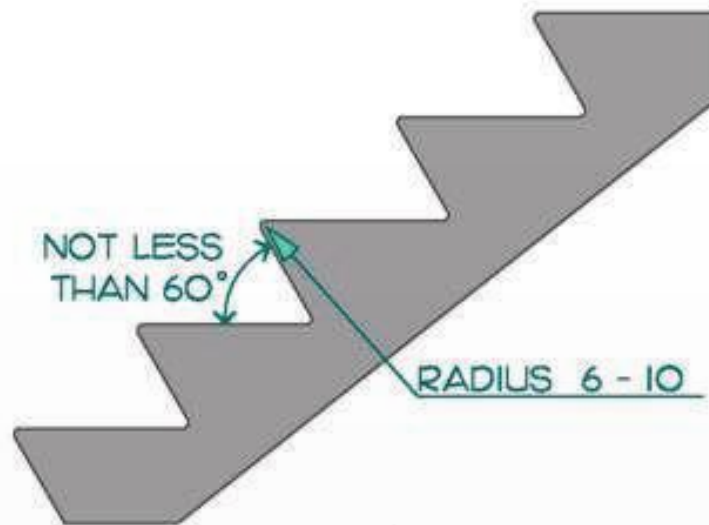

Figure 55: Stair Nosing

3.1.5.5 Other Considerations

- | | | | |
|--------|-----------------------------|------------|-------------------------|
| 2.2 | Anthropometric Data | Appendix B | Glare and Light Sources |
| 3.1.1 | Ground Surfaces | Appendix B | Illumination |
| 3.2.9 | Doors | Appendix B | Materials and Finishes |
| 3.3.13 | Handrails | Appendix B | Texture and Color |
| 3.4.1 | Signage | | |
| 3.4.6 | Detectable Warning Surfaces | | |



3.1.6 Kerb Cuts

3.1.6.1 Design Considerations

Well designed kerb cuts allow people to move safely and efficiently across roadways. An uneven transition or gap between the road surface and kerb cut can negatively impact a kerb cut design. Properly designed flared sides on a kerb cut eliminate the hazard of pedestrians stepping off of an abrupt edge. However, detectable warning, textured, and color contrasting surfaces become important safety features as the sloped surface of a kerb cut's flared edge may be a hazard to a person with a balance problem who may not notice the slope on the flared edge and while the smooth transitions and minimal slope are ideas for someone in a wheelchair, not notice the transition from the pavement to the street is a potential hazard to an individual with a visual impairment.



Figure 56: Detectable Warning Surfaces

Showing an example of a detectable warning surface used at a pedestrian crossing and bicycle path intersection.



Figure 57: Pedestrian Crossing

Showing an example of a pedestrian crossing using color and texture contrast.



3.1.6.2 Application Guidelines

Wherever an accessible route crosses a kerb, and where the ground levels on either side of the kerb are at different elevations, kerb cuts should be provided in compliance with this section.

3.1.6.3 Technical Guidelines

a. Slope: The running slope of a kerb cut should have a ratio between 1:50-1:20 (2%-5% slope). In a renovation situation, where it is technically infeasible to achieve these slopes, a running slope no steeper than 1:12 (8.3%) may be used.

b. Width: The minimum width of kerb cuts, not including any flared sides, should be 1500 mm. (*Figures 58, 59 and 60*)

c. Surface: Surfaces of kerb cuts should be firm, stable, slip-resistant, and incorporate a truncated dome detectable warning surface that complies with Section 3.4.8. Detectable warning surfaces at kerb cuts should be located 150–200 mm back from the kerb, extend the full width of the kerb cut and be 600 mm deep (*Figures 58, 59 and 60*). The transition between the kerb cut and adjacent roadway should be 10-15 mm high. (*Figure 61*)

d. Color Contrast: There should be a visually distinct color contrast between the kerb cut and surrounding surfaces.

e. Flared Sides: Flares on the each side of kerb cuts should be 900 mm in width, measured at the kerb end of the flare. Where pedestrian traffic is expected to cross the kerb cut, kerb cut flares should have a slope ratio of not more than 1:12. The flared sides of a kerb cut should be color contrasted from the surrounding surfaces.

f. Cross Fall: The slope of gutters and road surfaces, located immediately adjacent to the base of the kerb cut and sloping toward the kerb cut (known as cross fall), should have a maximum ratio of 1:20.

g. Drainage: Kerb cuts should be designed to drain water away from the kerb cut and should not allow water to accumulate on the path of travel.

h. Location: Kerb cuts at pedestrian crosswalks should be contained within the area designated for pedestrian use, for example within the boundaries of marked street crossings.



i. Alignment: Where multiple kerb cuts are utilised, such as at a pedestrian crosswalk containing a median, kerb cuts and ramps should be aligned to support continuous straight line travel. Kerb cuts and ramps that wrap around a corner can cause confusion in path direction and should not be utilised. Where it is technically infeasible to avoid the use of a kerb cut or ramp that wraps around a corner, then measures should be taken to assist pedestrians with low or no vision to properly align themselves when negotiating the kerb cut or ramp.

j. Detectable Warning Surfaces: Detectable warning surfaces are required at kerb cuts that serve unprotected pedestrian routes that cross vehicular routes. Detectable warning surfaces should extend along either side of the unprotected pedestrian route, be a minimum of 600 mm wide, and comply with Section 3.4.6.

k. Configuration: Typical kerb cut configurations are shown in Figures 58 to 60.

3.1.6.4 Illustrations

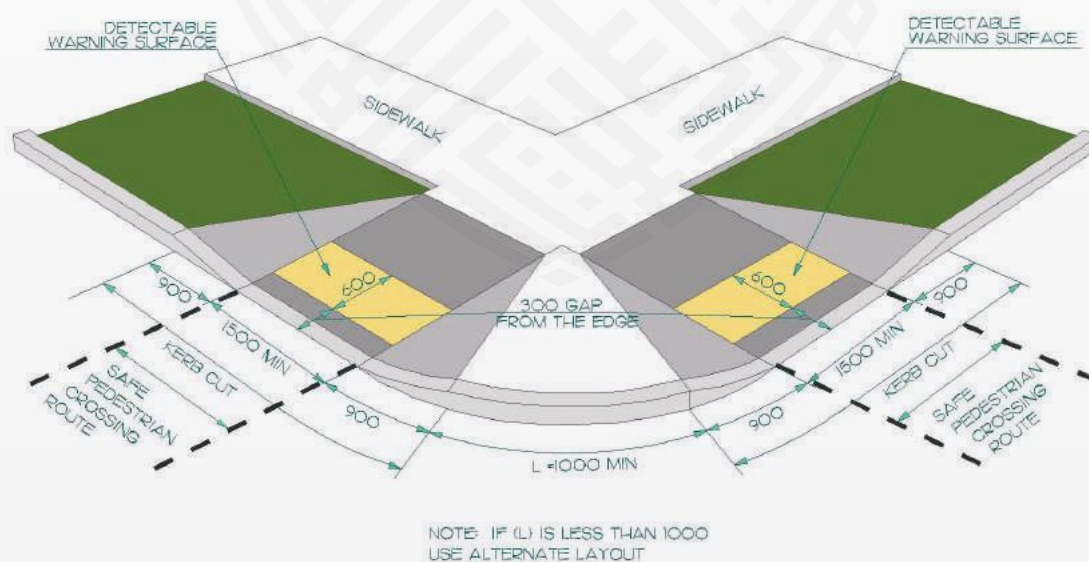

Figure 58: Kerb Cut Configuration at Corner

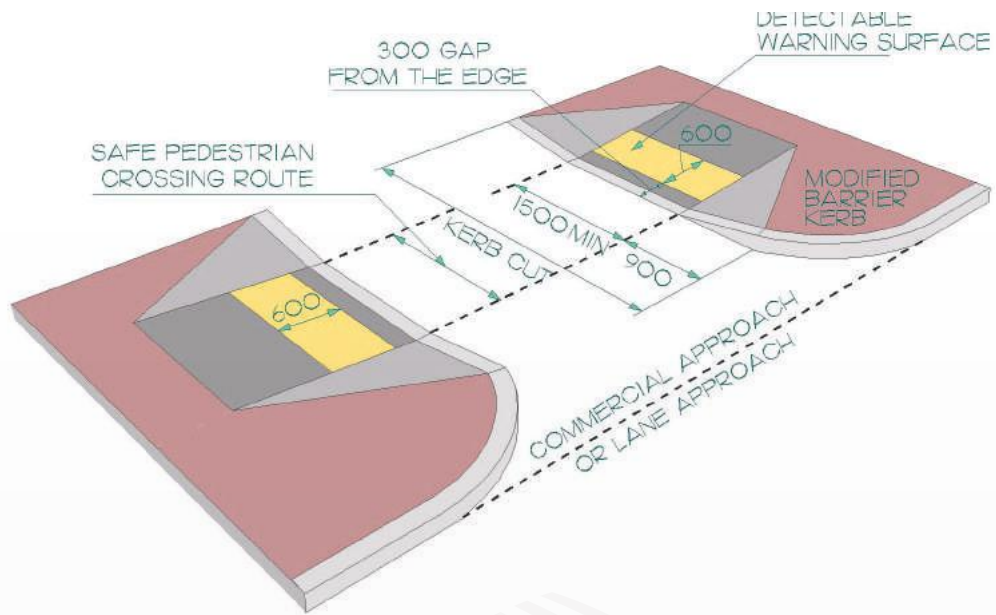

Figure 59: Kerb Cut Configuration Aligned

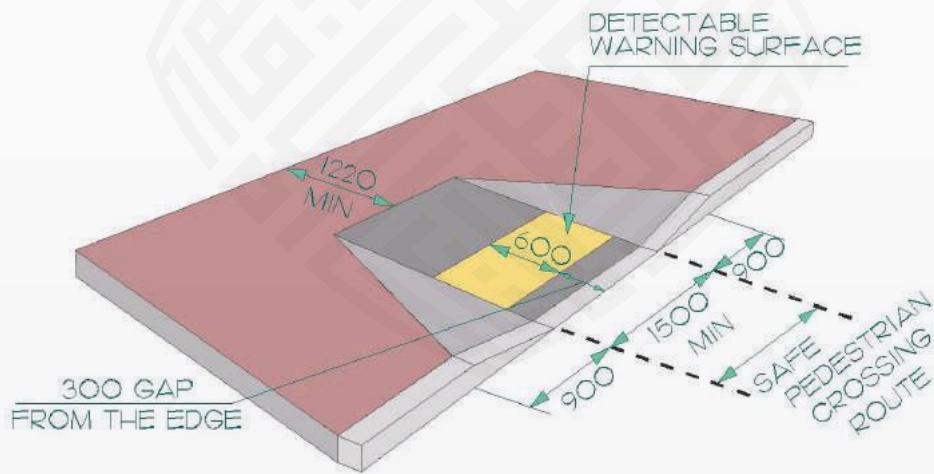

Figure 60: Kerb Cut Configuration Typical

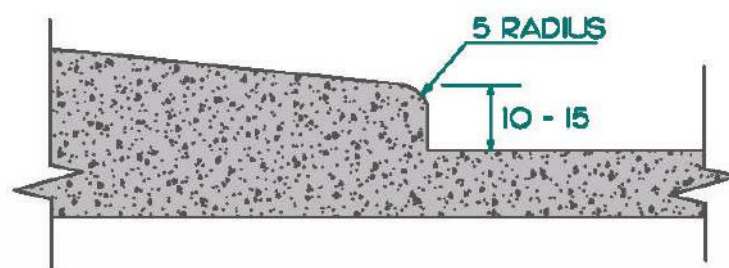
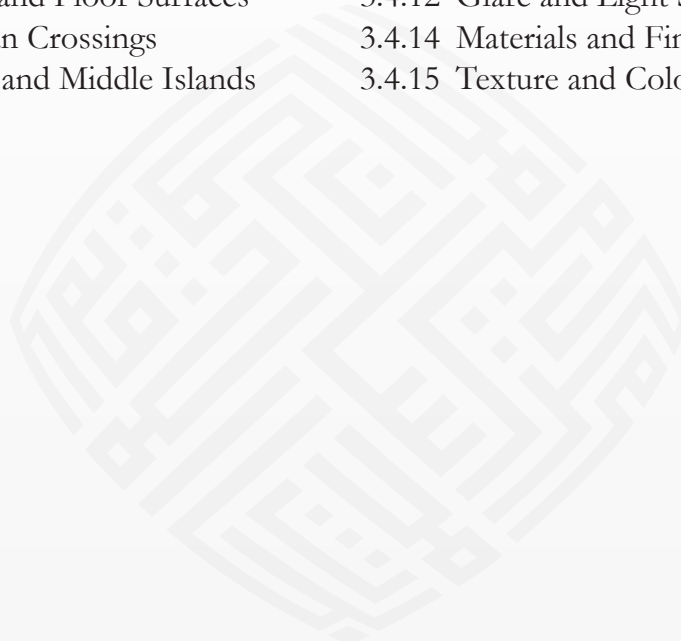

Figure 61: Transition at Base of Kerb cut

3.1.6.5 Other Considerations

- | | | | |
|-------|----------------------------|--------|-----------------------------|
| 2.2 | Anthropometric Data | 3.4.8 | Detectable Warning Surfaces |
| 3.1.1 | Ground and Floor Surfaces | 3.4.12 | Glare and Light Sources |
| 3.1.7 | Pedestrian Crossings | 3.4.14 | Materials and Finishes |
| 3.1.8 | Medians and Middle Islands | 3.4.15 | Texture and Color |





3.1.7 Pedestrian Crossings

3.1.7.1 Design Considerations

Pedestrian crossings should incorporate features to enhance safety for everyone. Crossing should incorporate color and texture contrast to reinforce the separation between people and vehicles. Raised crossings are more pedestrian friendly; however it is critical that continuous tactile warning surfaces be provided to demarcate the edge of the safe crossing route. Where kerb cuts are used in conjunction with pedestrian crossings, they should align with the safe crossing route across the vehicle roadway.

3.1.7.2 Application Guidelines

Where a pedestrian route is required to cross a vehicular roadway or driveway, the pedestrian crossing/crosswalk should comply with this section.

3.1.7.3 Technical Guidelines

- a. Path of Travel:** Pedestrian crossings should provide a minimum 1500 mm wide, continuous, unobstructed and linear path across the vehicular route.
- b. Surface:** Surfaces of pedestrian crossings should be firm, stable, slip-resistant, and produce low or minimal glare. Surfaces should have a texture that is easily distinguishable from the surrounding surfaces.
- c. Kerb cuts:** Where the surface of the pedestrian crossing is at a different elevation to either sidewalk that it connects, kerb cuts that comply with Section 3.1.6 shall be provided.
- d. Drainage:** Pedestrian crossings should be designed to drain water away from the crossing and should not allow water to accumulate on the path of travel.
- e. Markings:** Edge markings should be provided along both sides of pedestrian crossings. Edge markings should extend the entire length of the crossing, a minimum of 300 mm wide, and marked with permanent high-color markings possessing 70% reflectance with the surface of the crossing and the adjacent vehicle roadway.
- f. Traffic Control Signals:** Traffic control signals should provide enough time for people to cross the street safely, based on a slow walking person, and should also include time for people with low or no vision to verify that traffic has stopped. All crossings incorporating traffic control signals should include audible signals in addition to visual signals with one audible signal for the north-south direction of travel and another for



the east-west direction of travel. Audible signals should provide continued directional assistance to vision impaired pedestrians for the entire time period of crossing and be loud enough to be heard over traffic noise.

g. Traffic Control Buttons: Where traffic or pedestrian signals are controlled by a push button, the button should be color contrasted from the surrounding surfaces and a minimum of 100 mm in diameter. Push buttons should be aligned parallel to the traffic signals they service, be mounted 900-1200 mm above the ground, and adjacent to a clear and level area suitable for an approach by a person using a wheelchair, mobility scooter, or walker.

h. Raised Pedestrian Crossing: Raised crosswalks can reduce the height differential from the sidewalk to the pedestrian crossing and potentially eliminate the need for kerb cuts; additionally the raised crosswalk may benefit pedestrian safety by slowing traffic approaching the crosswalk. Raised pedestrian crossings should have a 600 mm wide truncated dome detectable warning surface in compliance with Section 3.4.6 that is continuous along the edges of walking surfaces where they abut the vehicular roadway. The clear width of the walking surface, between the detectable edges, should be no less than 1500 mm. The ground surface of the pedestrian walking area should be visually and tactilely distinguishable from surfaces (Figure 64).

3.1.7.4 Illustrations

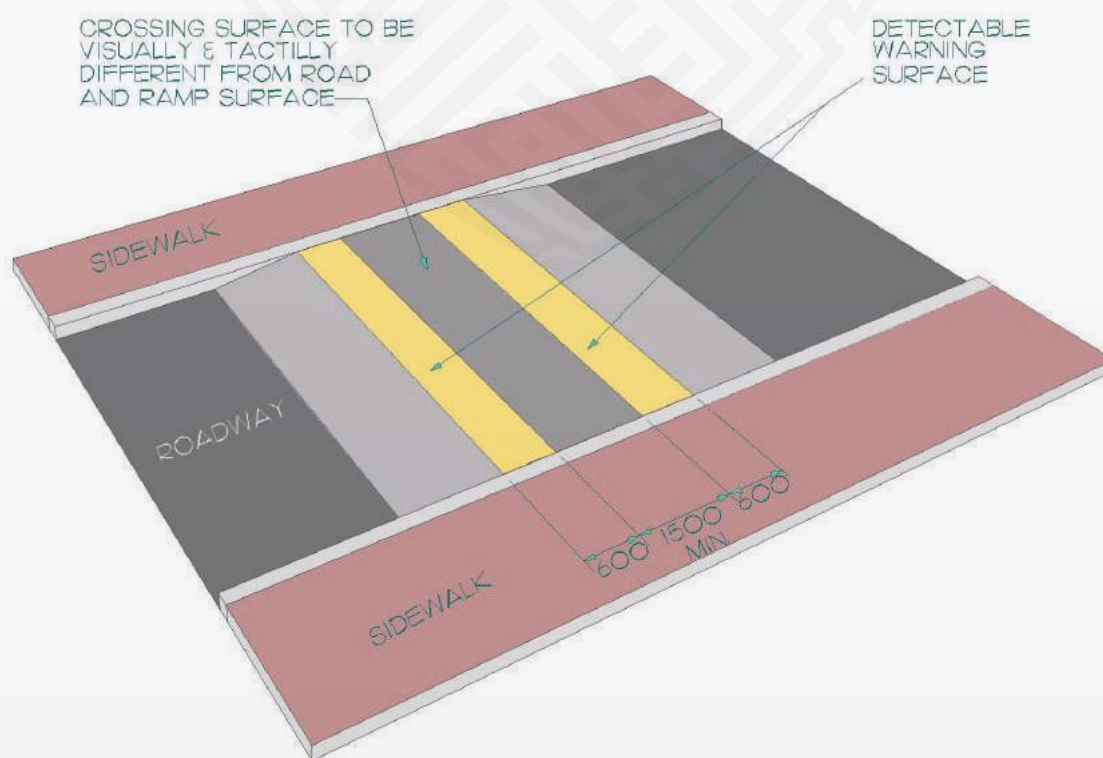

Figure 64: Raised Pedestrian Crossing



3.1.7.5 Other Considerations

- 2.2 Anthropometric Data
- 3.1.1 Ground and Floor Surfaces
- 3.4.8 Detectable Warning Surfaces

- 3.4.12 Glare and Light Sources
- 3.4.14 Materials and Finishes
- 3.4.15 Texture and Color





3.1.8 Medians and Middle Islands

3.1.8.1 Design Considerations

Medians and middle islands provide an area of safety for everyone - they are particularly useful at wide roads. Medians and middle islands should be provided wherever possible; to assist people who cannot walk quickly, or who have stamina limitations and may need to rest partway across a road. The medians and middle islands should be large enough to accommodate a wheelchair or mobility scooters, and should feature detectable warning surfaces to clearly differentiate safe pedestrian area from unsafe traffic areas.

3.1.8.2 Application Guidelines

Where a pedestrian route is required to cross a vehicular roadway where medians or intermediate islands are provided, the medians or intermediate islands should comply with this section.

3.1.8.3 Technical Guidelines

a. Width: The walkway across an island or median should be a minimum of 1500 mm wide and be a minimum 1400 mm deep to ensure that people using mobility devices are not exposed into the roadway on either side.

b. Surface: Surfaces of medians and traffic islands should be firm, stable and slip-resistant. The walkway across a traffic island or median should be color and texture contrasted from the surrounding surfaces.

c. Drainage: Medians and traffic islands should be designed to drain water away from the island and should not allow water to accumulate on the path of travel.

d. Elevation: The path of travel through narrower traffic islands or medians should be level with the pedestrian crossing (*Figure 67*). Wider medians or traffic islands may incorporate kerb cuts, but should have a level area on the median or traffic island at least 1400 mm long (*Figure 68*).

e. Kerb cuts: Kerb cuts should comply with Section 3.1.6.

f. Detectable Warning Surfaces: Where a traffic island, designed as part of a crosswalk, has a surface that is level with the adjacent roadway, a detectable warning surface that complies with Section 3.4.8 should be provided at each location where the island meets the roadway. Detectable warning surfaces should extend the full width of the walkway, be 600 mm in depth and comply with Section 3.4.6.



3.1.8.4 Illustrations

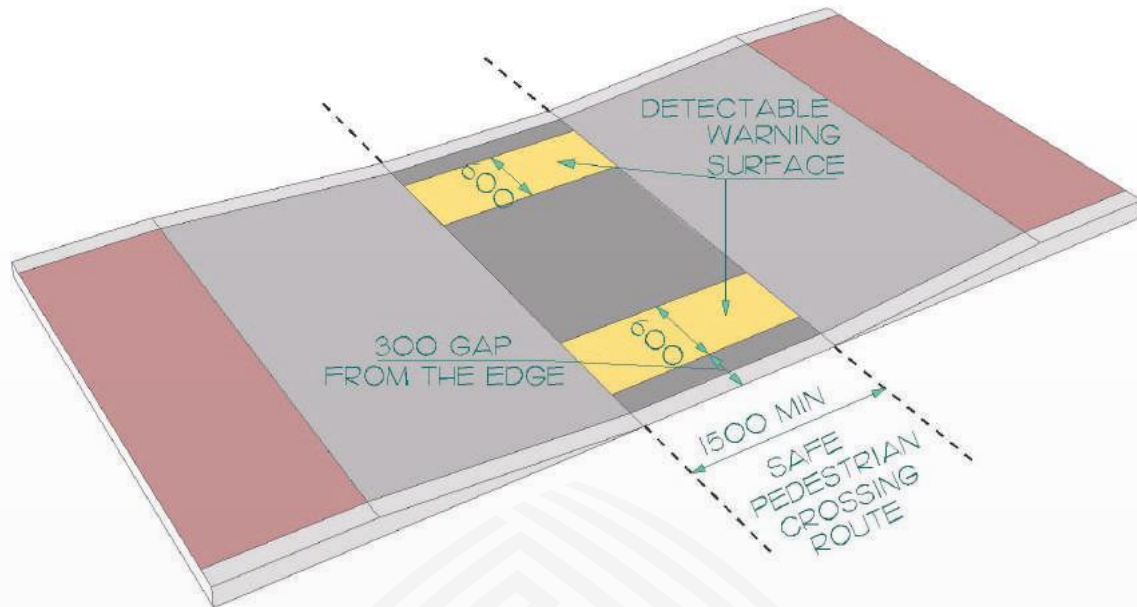

Figure 67: Narrow Median/Traffic Island

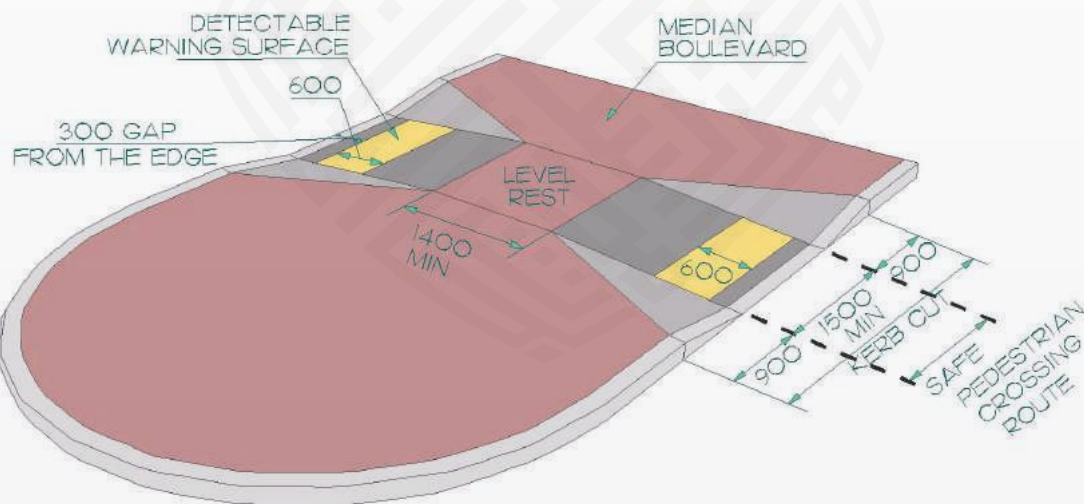

Figure 68: Wide Raised Median

3.1.8.5 Other Considerations

- | | | | |
|-------|-----------------------------|--------|-------------------------|
| 2.2 | Anthropometric Data | 3.4.12 | Glare and Light Sources |
| 3.1.1 | Ground and Floor Surfaces | 3.4.14 | Materials and Finishes |
| 3.4.8 | Detectable Warning Surfaces | 3.4.15 | Texture and Color |



3.1.9 Vehicle Parking

3.1.9.1 Design Considerations

Parking spaces near the entrance to a facility accommodate people with a variety of abilities, as well as, people with limited mobility and those caring for small children. Medical or other conditions, such as arthritis, heart conditions, people who are pregnant, those people using crutches, or the physical act of pushing a wheelchair, all make it difficult to travel long distances. Outdoor travel distances should be minimized as weather conditions and ground surfaces can make travel both difficult and hazardous. The parking area should be directly connected to the entrance of a facility. It should also be clearly marked and free of steps and kerbs.



Figure 69: Accessible Parking Spaces

The size of accessible parking spaces is particularly important. Wider parking spaces are necessary for people who use mobility aids such as a scooters or wheelchairs. Space is required beside the car or van for manoeuvring space to enter or exit the vehicle. Additional space is may also be required to allow people who use mobility aids to operate a lift or ramp through the side or back door of their vehicle. In such situations, space is required for the lift/ramp itself, as well as space beyond to allow people to access the lift/ramp.

People with limited mobility, expectant mothers, caregivers, and people who use walkers, canes, crutches, and strollers can be accommodated by wider courtesy parking spaces near the entrance to a facility - identified in this section as a “Limited Mobility Parking”. People who would benefit from close proximity parking do not all require a designate access aisle adjacent to a designated parking space.



The clear height available along the routes to accessible parking spaces is an important to allow for additional overhead clearances are required for accessible vans with raised roofs. Additionally, speed bumps and pavement slope transitions should incorporate lower tolerances, as the floors of many accessible vans are lowered.

Where increased numbers of people with disabilities are anticipated at a particular facility, an increased number of accessible parking spaces should be considered.

Wherever possible parking signs should be located away from pedestrian routes, where they will not become an overhead and/or protruding hazard.

3.1.9.2 Application Guidelines

These guidelines are intended to apply to all new parking structures and surface parking areas. Where existing parking structures and surface parking areas are being renovated or altered, these standards should be implemented to the greatest extent possible.

Designated parking spaces should include both Accessible Parking and Limited Mobility Parking.

The minimum number of designated parking spaces should be in accordance with Figure 70 below. Additional designated parking spaces should be allocated where a higher frequency occurs of people with disabilities, such as at: hospitals, medical facilities, nursing homes, facilities for the senior and the elderly.

Total Number of Automobile Parking Spaces Provided	Minimum Number of Designated Accessible Parking Spaces	Minimum Number of Designated Limited Mobility Parking Spaces
1 – 50	1	1
51 – 100	2	2
101 – 200	4	2
201 – 300	5	3
301 - 500	6	4
501 and over	6 plus 1 for each 100 over 500	4 plus 1 for each 100 over 500

Figure 70: Designated Accessible Parking Space Guidelines



3.1.9.3 Technical Guidelines

a. Location: Designated accessible spaces should be located at the shortest distance to the accessible entrance that it serves, or the closest accessible entrance where multiple locations are served. Designated parking spaces should be located adjacent to an accessible route that complies with Section 3.1.3.

b. Path of Travel: The path of travel from the designated accessible parking spaces to the accessible entrance should minimize crossing of vehicular and pedestrian traffic flows. Access to the adjacent accessible route from the accessible parking space should be via the required access aisles at the accessible parking space. Where the location of the accessible entrance/s served is not clearly visible from the designated parking spaces, directional signage to the entrances should be provided at the designated parking space area.

c. Identification Signage: Designated parking spaces should be capable of being identified clearly from a distance and should comply with Section 3.4.1. Such signage should measure at least 300 mm wide by 450 mm high and should include the International Symbol of Access. Signs should be mounted vertically on a post that is color contrasted with the surrounding environment and should be installed at a height of at least 2100 mm from the ground, measured to the bottom of the sign. For perpendicular parking spaces, signs should be centred across the parking space, and for parallel parking spaces, signs should be located toward the head of the parking space. Avoid mounting signs on fences or building faces. (*Figure 71*)

d. Directional Signage: At locations of vehicular entry and at intersections located between vehicle entry points and designated parking spaces, where the designated parking spaces are not clearly visible, directional signage should be provided to the designated parking spaces. Directional signage should include the International Symbol of Access, directional arrows and should comply with Section 3.4.1.

e. Pavement Markings: Designated parking spaces should include pavement markings that contain the International Symbol of Access in compliance with Section 3.4.1. Pavement markings should measure 1500 x 1500 mm with a white border and blue background.

f. Layout-Perpendicular Parking: Accessible parking spaces where vehicles are positioned perpendicular to the adjacent accessible route, should measure at least 2400 mm wide by 6100 mm deep. Perpendicular accessible parking spaces should have an access aisle adjacent to it that measures 2100 mm wide and that extends the entire length of the accessible parking space. Access aisles should be clearly marked to prevent obstruction. Adjacent accessible parking spaces are permitted to share an access aisle which should be located adjacent to both. In a renovation situation where it is technically infeasible to provide a 2100 mm wide access aisle, the width of the access aisle may be reduced to a minimum of 1500 mm. (*Figure 72*)



g. Layout-Parallel Parking: Accessible parking spaces where vehicles are positioned parallel to the adjacent accessible route, should measure at least 5400 mm wide and 3900 mm deep. Parallel accessible parking spaces should have an access aisle adjacent to it that measures 2100 mm wide and extends the entire depth of the accessible parking space. Access aisles should be clearly marked to prevent obstruction. Adjacent accessible parking spaces are permitted to share an access aisle which should be located adjacent to both. In a renovation situation where it is technically infeasible to provide a 2100 mm wide access aisle, the width of the access aisle may be reduced to a minimum of 1500 mm. (*Figure 73*)

h. Layout-Angled Parking: Accessible parking spaces where vehicles are positioned at an angle other than perpendicular or parallel to the adjacent accessible route, should measure at least 6350 mm deep and 2900 mm wide. Angled accessible parking spaces should have an access aisle adjacent to it that measures 2100 mm wide and extends the entire length of the accessible parking space. Access aisles should be clearly marked to prevent obstruction. Adjacent accessible parking spaces are permitted to share an access aisle which should be located adjacent to both. In a renovation situation, where it is technically infeasible to provide a 2100 mm wide access aisle, the width of the access aisle may be reduced to a minimum of 1500 mm. (*Figure 74*)

i. Floor and Ground Surface: Floor and ground surfaces at designated parking spaces and adjacent access aisles should have a firm, stable surface with a maximum 1:50 (2%) for both running and cross slopes.

j. Overhead Clearance: The minimum overhead clearance required to extend along the entire route from vehicle entry/exit to the designated parking space location/s should be 2750 mm above the floor. The required minimum overhead clearance may be reduced for indoor parking areas to a minimum of 2600 mm high; Signage should be provided at vehicle entry points clearly indicating the minimum overhead clearance.

k. Limited Mobility Parking: Limited Mobility Parking spaces should be a minimum 2400 mm wide and 6100 mm deep. Limited Mobility Parking spaces should have an access aisle adjacent to it that is at least 1200 mm wide. Access aisles should be clearly marked to prevent obstruction. Adjacent accessible parking spaces are permitted to share an access aisle which should be located adjacent to both. Limited Mobility Parking spaces should include the Limited Mobility symbol complying with Section 3.4.1. (*Figure 75*)



3.1.9.4 Illustrations

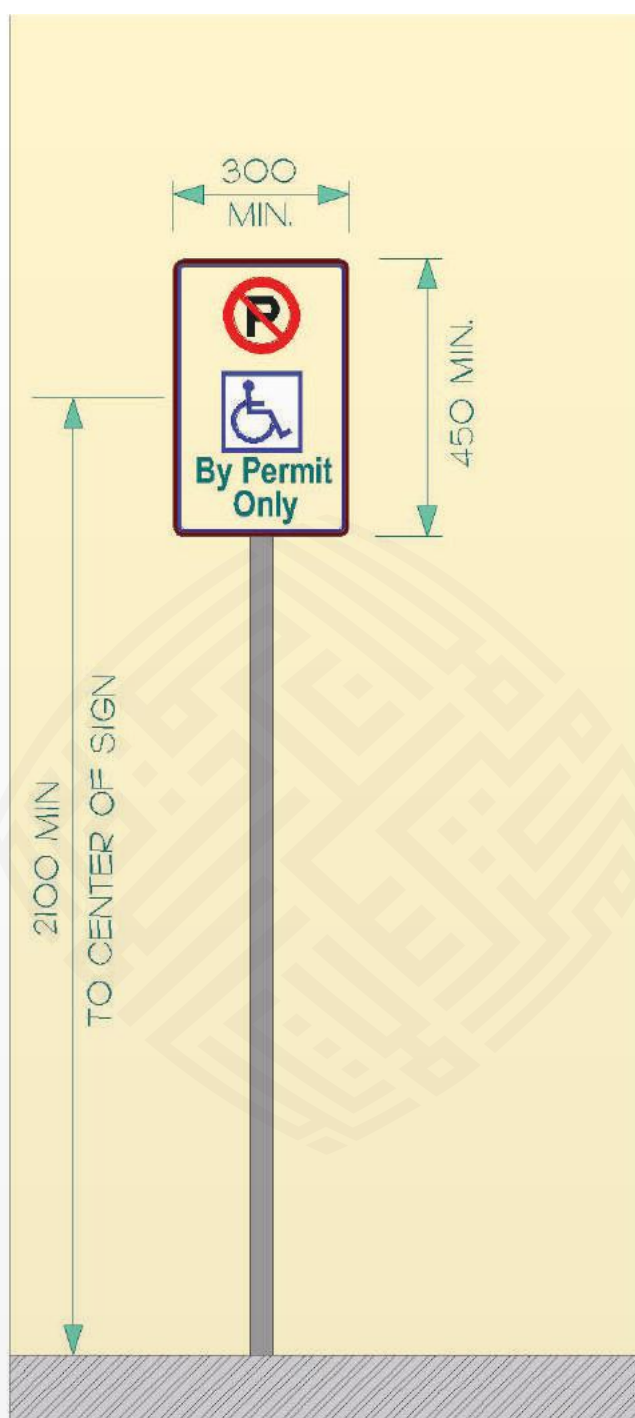

Figure 71: Designated Parking Signage

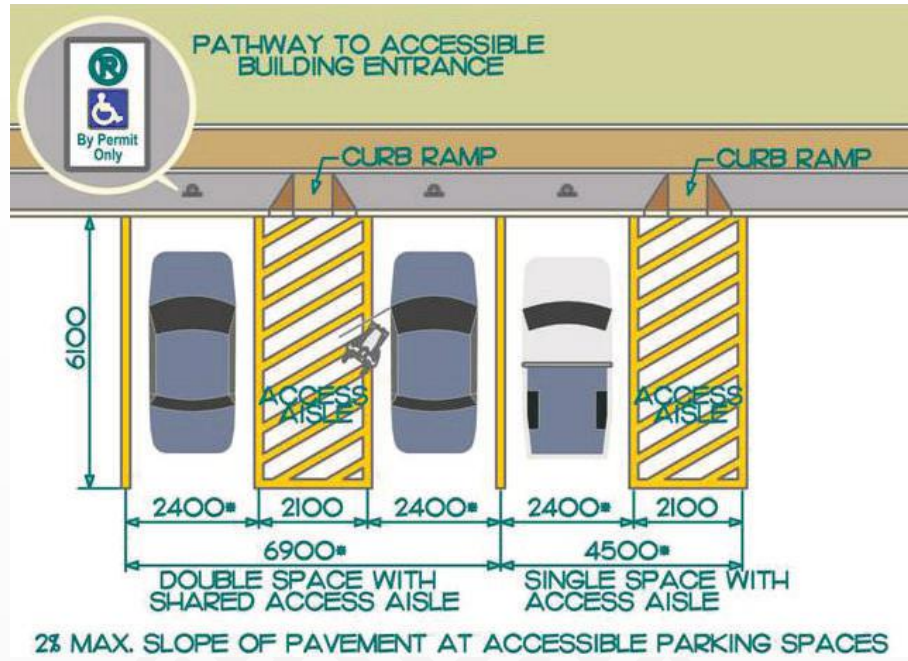

Figure 72: Perpendicular Parking Spaces

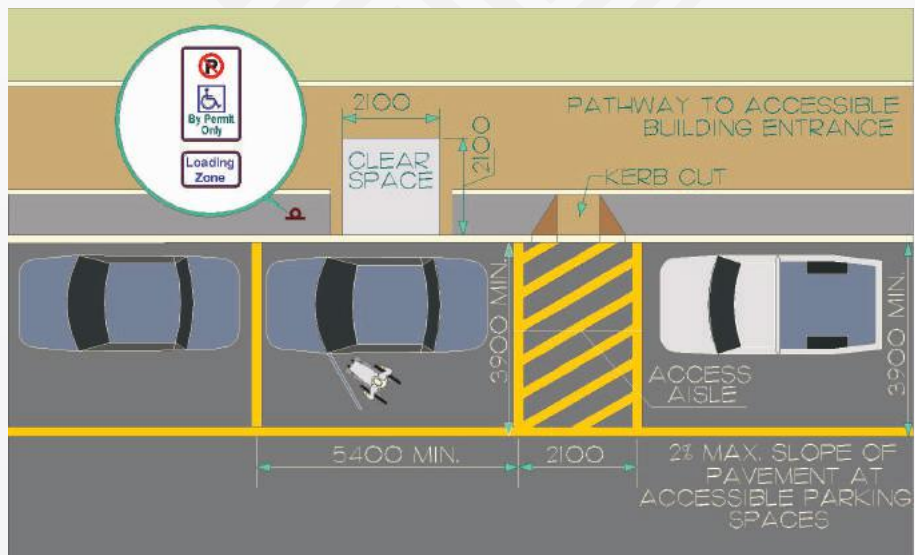

Figure 73: Parallel Parking Spaces

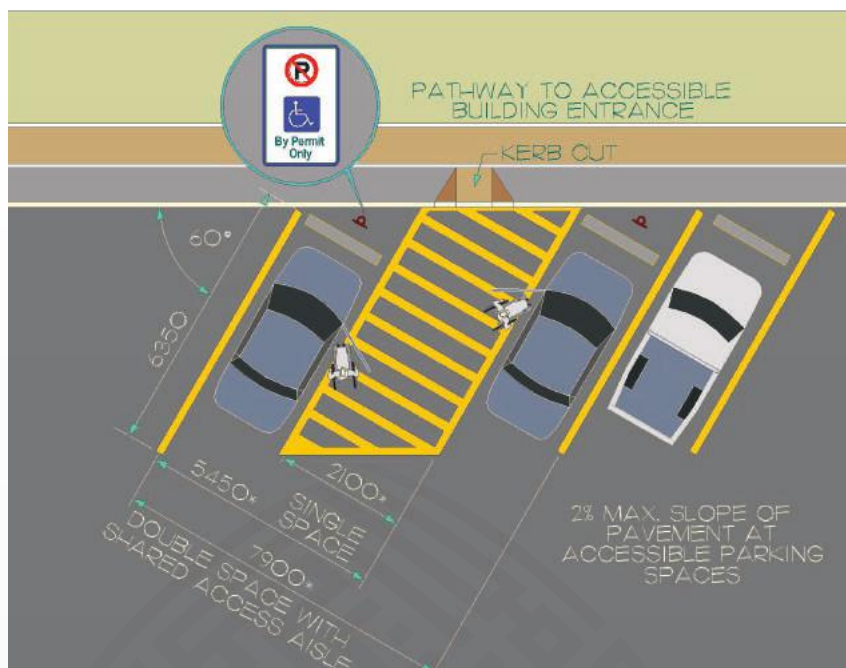

Figure 74: Angled Parking Spaces



Figure 75: Limited Mobility Parking Spaces



3.1.9.5 Other Considerations

- 2.2 Anthropometric Data
- 3.1.1 Ground and Floor Surfaces
- 3.1.2 Overhead and Protruding Objects
- 3.1.3 Sidewalks, Pavements, Paths and Routes
- 3.1.9 Kerb cuts
- 3.4.6 Detectable Warning Surfaces
- 3.4.7 Signage
- 3.4.13 Illumination
- 3.4.14 Materials and Finishes
- 3.4.15 Texture and Color





3.1.10 Passenger Drop-off Areas

3.1.10.1 Design Considerations

It is important to incorporate accessible passenger loading zones for people who are dropped-off, arrive by taxi or use a parallel transit bus. Drop-off areas should be as close as possible to an accessible entrance for individuals who may have difficulty walking distances. Space for the deployment of lifts or ramps, as well as appropriate overhead clearances, should be provided for accessible transit vehicles. All users, especially people using mobility assistive devices, will benefit from weather-protection features such as sun-shades and canopies.

3.1.10.2 Application Guidelines

Passenger drop-off areas should comply with this section.

Signage, complying Section 3.4.1., should be used to identify accessible passenger drop-off areas.

If a passenger drop-off area is also a designated mobility transit stop zone, it should comply with all relevant local bylaws.

3.1.10.3 Technical Guidelines

a. Location: Passenger-loading zones should be on an accessible route complying with Section 3.1.3.

b. Floor and Ground Surface: Floor and ground surfaces at designated parking spaces and adjacent access aisles should have a firm, stable surface with a maximum 1:50 for both running and cross slopes.

c. Signage: Passenger loading/drop-off zones should be clearly identified with signage that complies with Section 3.4.1. Such signage should measure a minimum of 300 mm wide by 450 mm high and should include the International Symbol of Access. Signs should be mounted vertically on a post that is color contrasted with the surrounding environment and should be installed at a height of at least 2100 mm from the ground, measured to the bottom of the sign. Signs should be posted at both ends of the drop-off zone.

d. Overhead Clearance: Passenger loading/drop-off zones should have a minimum overhead clearance of 3600 mm, at the loading/drop-off zone and along the vehicle access route to vehicle entry/exit points. (Figure 76)



e. Off-Street Zone Size: Off-street passenger loading zones should measure a minimum of 2700 mm deep by 7000 mm wide and have an access aisle adjacent to it that is at least 2100 mm wide, extending the entire length of the loading zone. In a renovation situation where providing a 2100 mm wide access aisle is technically infeasible, the access aisle width may be reduced to 1500 mm. (Figure 77)

f. On-Street Zone Size: On-street passenger loading zones should measure a minimum of 3900 mm deep by at least 5400 mm wide, with an adjacent access aisle at least 3900 mm deep by 2100 mm wide. (Figure 78)

g. Kerb cuts: Where there is a kerb between the access aisle and the vehicle pull-up space, a kerb cut should be provided that complies with Section 3.1.6.

h. Weather Protection: Passenger loading zones should provide sufficient protection from harsh weather conditions, including but not limited to, wind, rain, sun and snow.

3.1.10.4 Illustrations

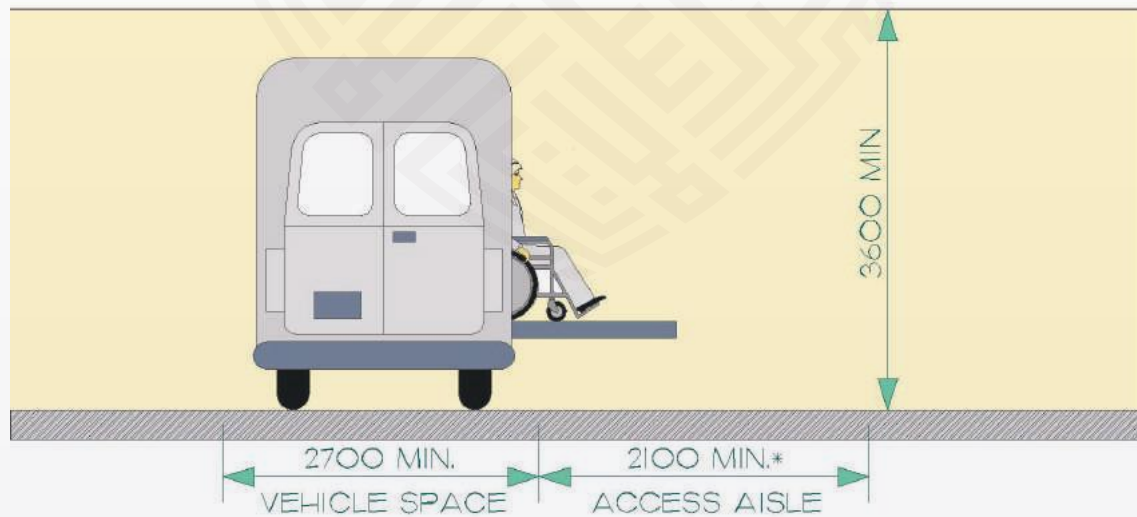

Figure 76: Height Clearance at Passenger Loading Zone

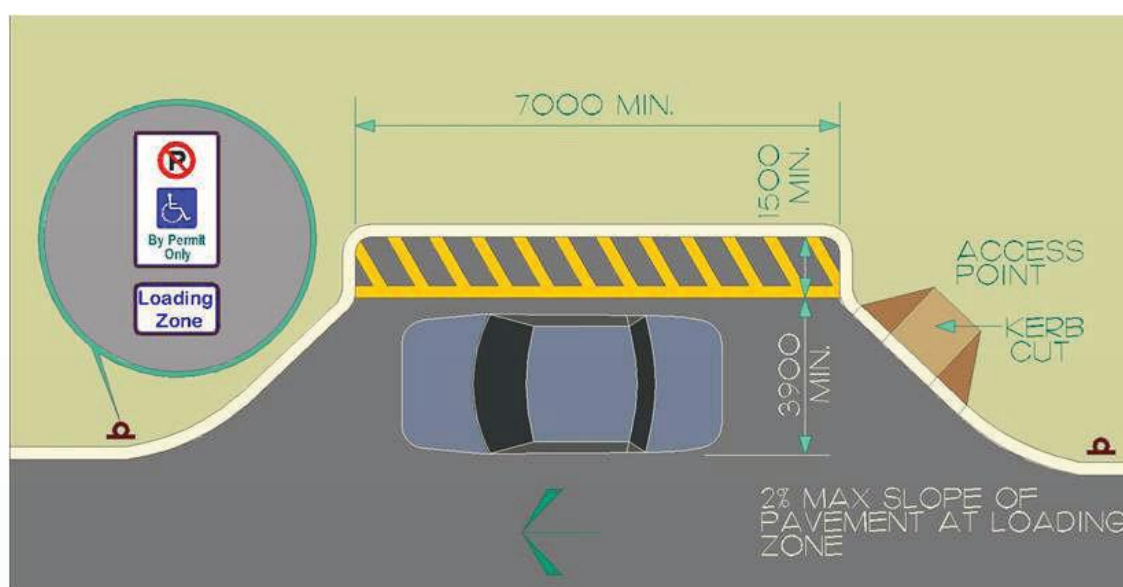

Figure 77: Off-Street Passenger Loading Zone

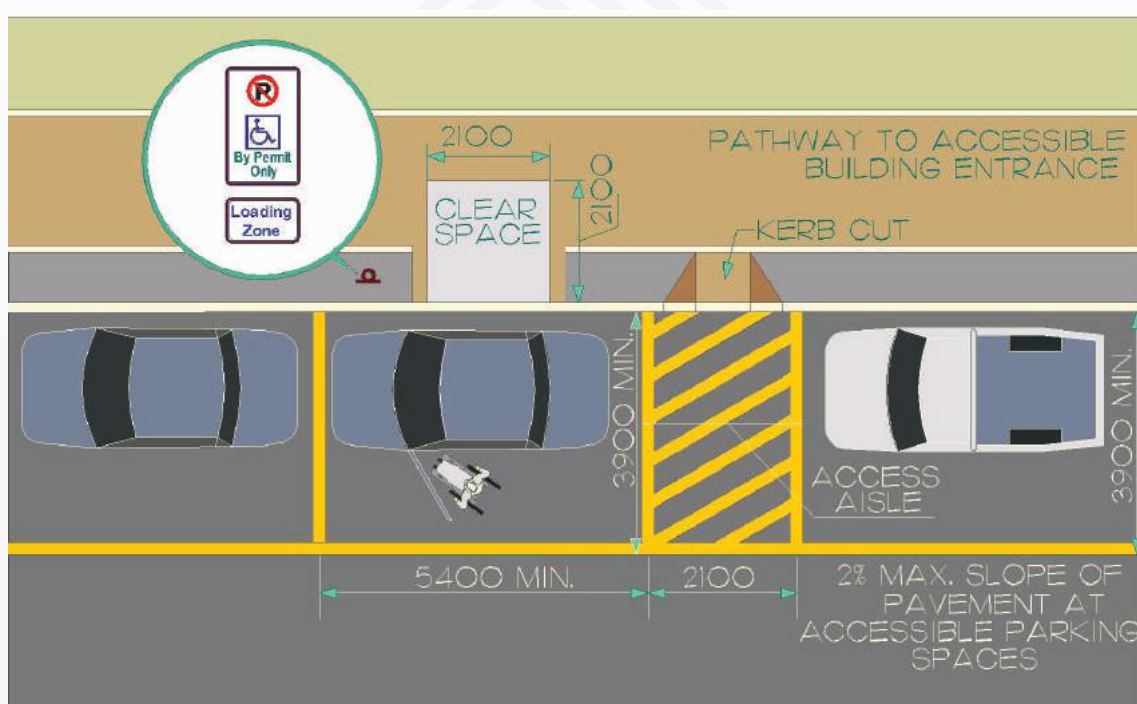

Figure 78: On-Street Passenger Loading Zone

3.1.10.5 Other Considerations

- | | |
|--|-----------------------------------|
| 2.2 Anthropometric Data | 3.4.6 Detectable Warning Surfaces |
| 3.1.1 Ground and Floor Surfaces | 3.4.7 Signage |
| 3.1.2 Protruding and Overhead Objects | 3.4.13 Illumination |
| 3.1.3 Sidewalks, Pavements, Paths & Routes | 3.4.14 Materials and Finishes |
| 3.1.9 Kerb cuts | 3.4.15 Texture and Color |



3.1.11

Landscaping Materials and Plantings

3.1.11.1 Design Considerations

Landscape materials, trees, shrubs, and plants are important features of an accessible outdoor environment. Fragrant plants and shrubs can be strategically placed to provide an olfactory guide for people with visual impairments, while flowers with contrasting colors can be used to mark the edges of pathways.

Plants with thorns and those that drop large seed pods should be avoided to prevent walking hazards and obstructions to wheels. Likewise, overhanging plantings and tree limbs are potentially dangerous, especially to people with visual impairments.

For people who use mobility devices and those who have difficulty bending, raised beds will improve access to plantings.

The use of unit pavers should be avoided unless it can be laid over a structural slab, as the effects of settlement and heave will produce a difficult walking/wheeling surface. In addition, the space between pavers should be limited to prevent excessive vibration to people using mobility devices such as wheelchairs or mobility scooters.



Figure 79: Raised Planters



3.1.11.2 Application Guidelines

All landscaping materials and plantings should comply with this section. Where plant beds are provided for use by the general public, clients, customers, or employees, then 10% of the area of plant beds, but not less than one, should comply with this section.

3.1.11.3 Technical Guidelines

a. Location: Accessible plant beds should be located on accessible routes that meet the specifications of Section 3.1.3.

b. Height of Accessible Plant Beds: Accessible plant beds should be located 440 mm above the ground surface.

c. Kerbs and Guards for Pedestrian Walkways: The edges of planting beds located immediately adjacent to pedestrian walks should be clearly defined. Where variations in grading immediately adjacent to pedestrian walks are potentially hazardous (particularly to people who are visually impaired), the hazardous edges of the walk should incorporate clearly defined, color-contrasting and cane-detectable kerbs at least 75 mm above the walk surface. Different materials could be used to accomplish this requirement including concrete or rocks for example.

d. Hazardous Plants & Materials: A minimum distance of 900 mm should be maintained between shrubs with thorns and sharp edges away from accessible pathways and seating areas. Plants that drop large seed pods should not overhang or be positioned near accessible paths or walkways.

e. Guide Wires: In areas used by clients, customers, general public, or employees, permanent guide wires should not be used. Temporary guide wires, such as those used when planting new trees, may be permitted if they are easily discernable and incorporate strong color contrasts.

f. Overhead Protrusions and Tree Guards: Tree guards should comply with Section 3.1.2. The headroom at any part of a walkway or path should not be reduced to less than 2100 mm by overhanging branches of trees or shrubs.

g. Ground Surfaces: Ground surfaces should comply with Section 3.1.1. Common accessible surfacing materials for pathways include: poured concrete, interlocking stones, paving slabs, asphalt, rubberized surfaces, or crushed stone. Floor and Ground Surfaces should have a maximum cross slope of 1:50.



h. Orientation Cuing: Plantings can be used to provide orientation cues, for example, by lining pathways with colorful flowers or strategic position of fragrant plantings. Fragrant plantings can also provide an environment that can be enjoyed by a broader range of users. Similarly, the use of features such as fountains, provide additional auditory cues to assist with orientation and way-finding. Care should be taken to avoid plants that are common allergens.

3.1.11.5 Other Considerations

- 2.2 Anthropometric Data
- 3.1.1 Ground Surfaces
- 3.1.2 Overhead and Protruding Objects
- 3.1.3 Sidewalks Pavements, Path and Routes





3.1.12

Street Furniture

3.1.12.1 Design Considerations

Street furniture that includes seating, functions as an accessible resting place for people who face difficulties with long distance travelling. All exterior furniture should be designed with strong color contrasts and placed away from pathways, to minimize obstructions to pedestrian traffic flow.



Figure 80: Street Furniture
Street furniture located out of accessible route.



Figure 81: Contrast Border
Texture and color-contrast border at obstacle.

3.1.12.2 Application Guidelines

All street furniture within a site, inside or outside of facilities, should comply with this section. This includes such furniture as waste receptacles, light standards, signs, planters, mail boxes and vending machines.

Waste disposal should be available to people using wheelchairs or other mobility devices, including alternate accessible facilities where waste receptacles are located in unpaved areas of parks, wilderness, beach, unpaved picnic areas. Exception: large industrial containers.

3.1.12.3 Technical Guidelines

a. Location: Street furniture should not reduce the required width of an accessible route that complies with Section 3.1.3. Street furniture should be consistently located to one side of the path of travel. Street furniture should be stable and securely fixed in place. (*Figure 82*)



b. Protruding Objects and Overhead Hazards: Street furniture should be cane-detectable and comply with Section 3.1.2.

c. Waste Receptacles: Waste receptacles should be provided on the exterior side, close to each accessible public entrance. Waste receptacles should be large enough to contain a volume of waste that avoids overflowing of the waste causing potential tripping hazards. Waste receptacles should be mounted on firm, stable, and level pads. Waste receptacles should be clearly identified by lettering that complies with Section 3.4.1. Receptacle lids or openings should be mounted no higher than 1060 mm above the ground surface. Opening mechanisms, where provided on waste receptacles, should comply with Section 3.3.10.

d. Color and Texture Contrast: Street furniture should be color contrasted to the surrounding environment. Along kerb edges containing indicator surfaces and where street furniture is located, the indicator surface should be widened to accommodate and contain all street furniture. (Figure 82)

3.1.12.4 Illustrations

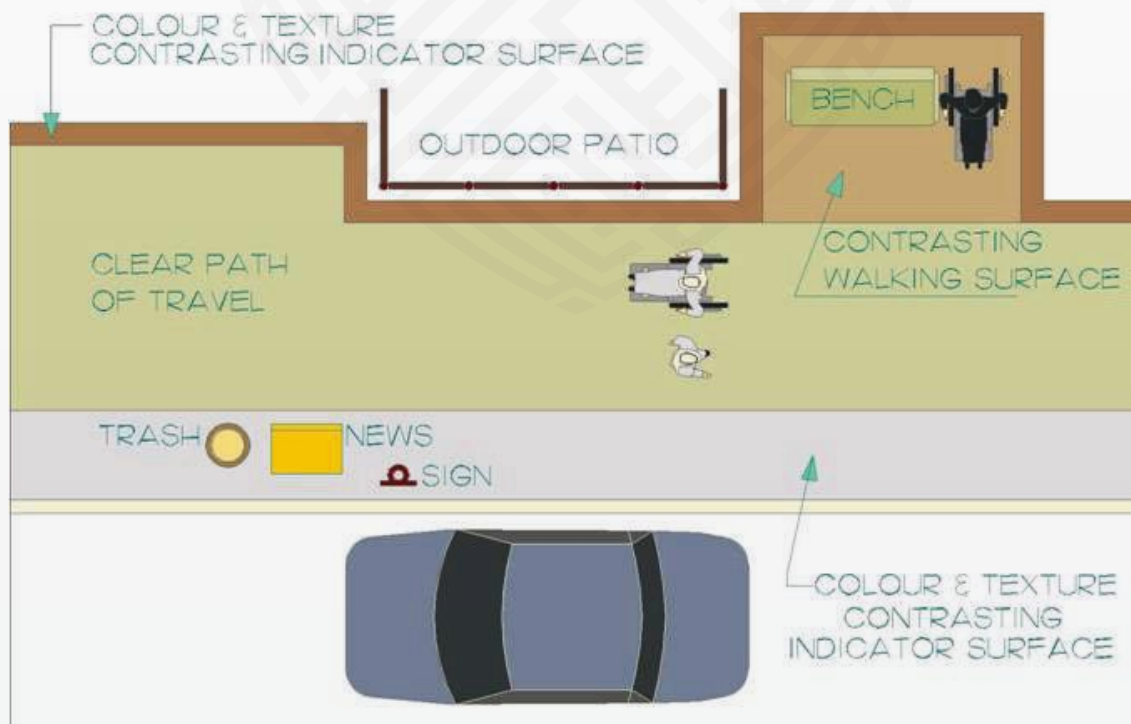

Figure 82: Streetscape

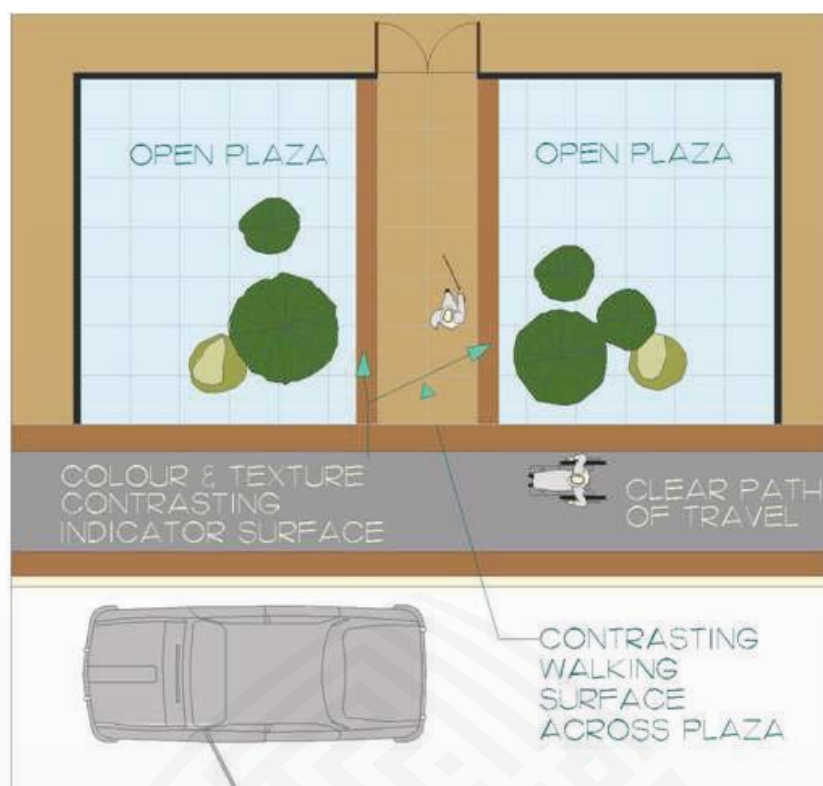

Figure 83: Pathway Across Open Plaza

3.1.12.5 Other Considerations

- 2.2 Anthropometric Data
- 3.2.2 Routes, Corridors and Access Aisles
- 3.4.6 Detectable Warning Surfaces
- 3.2.25 Floor Surfaces
- 3.2.26 Overhanging and Protruding Objects

Appendix B Materials and Finishes

Appendix B Texture and Color



3.1.13 Gates and Turnstiles

3.1.13.1 Design Considerations

Gates and turnstiles should be designed to accommodate a range of individuals with varying abilities. For children, people of short stature and people who use wheelchairs or mobility scooters, the height of single-bar gates should not correspond with face or neck height. People using canes or crutches and those with poor balance will have difficulty negotiating a revolving turnstile, while people who use wheelchairs will be unable to traverse a turnstile at all. An adjacent opening of an accessible width is recommended to address the needs of not only people with wheelchairs and mobility devices including walkers, but also with strollers or delivery carts.



Figure 84: Turnstiles

Showing an accessible turnstile, incorporating color and surface indicators.



3.1.13.2 Application Guidelines

All gates, turnstiles, and openings should comply with this section

3.1.13.3 Technical Guidelines

a. Gates or Openings to Public Use Areas: Gates or openings to public use areas should have a minimum clear unobstructed width of 900 mm. Closing devices where installed at gates or openings should not be spring loaded and hardware where installed should comply with Section 3.3.10. Gates should be cane-detectable and comply with Section 3.1.2. Gates or openings should be identified using the international symbol of accessibility. (Figures 85 and 86)

b. Turnstiles or Other Ticket Controlled Devices: Where turnstiles or other ticket controlled devices are installed, an accessible gate or opening should be provided in close proximity. (Figure 85)

c. Color Contrast: Contrasting colors should be used to differentiate turnstiles from the surrounding environment. Contrasting color should be provided on either side of gates and openings at the supporting members or posts.

3.1.13.4 Illustrations

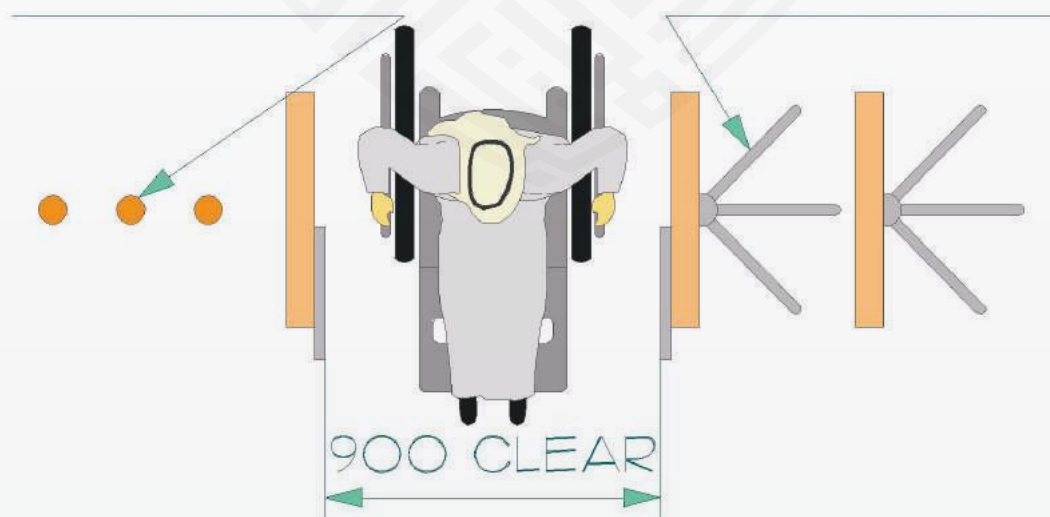

Figure 85: Access at Turnstile

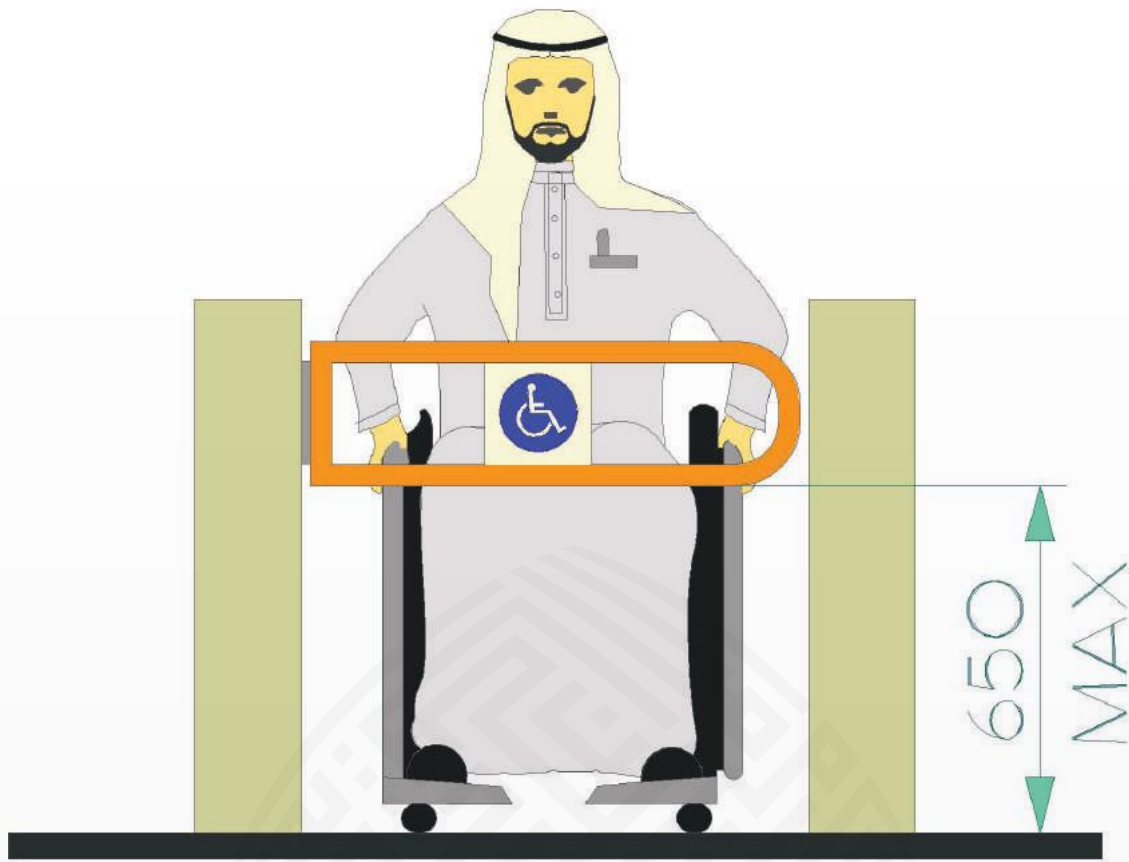

Figure 86: Access at Turnstile

3.1.13.5 Other Considerations

- 2.2 Anthropometric Data
- 3.2.9 Doors
- 3.2.10 Windows, Glazed Screens and Sidelights
- 3.3.10 Controls and Operating Mechanisms
- 3.4.1 Signage
- 3.4.4 Information Systems
- 3.4.5 Card Access, Safety and Security Systems



3.1.14 Courtyards and Balconies

3.1.14.1 Design Considerations

When courtyards and balconies are incorporated into design plans, a range of sun and wind protection options should be considered for individuals who have varying tolerances to the elements. Glazed surfaces should be marked to alert users to their presence. Balcony door thresholds should be minimized as much as possible.

3.1.14.2 Application Guidelines

Courtyards and balconies used by the general public, clients, customers, or employees should comply with this section.

3.1.14.3 Technical Guidelines

a. Location: Balconies and courtyards should be located on accessible route that complies with Section 3.1.3.

b. Depth: Balconies and courtyards should be a minimum of 2100 mm deep. In renovations where the required depth is technically infeasible, the minimum depth may be reduced to 1500 mm.

c. Thresholds: Where exterior balconies, porches, terraces, and patios, are directly accessible from interior spaces and incorporate thresholds, the thresholds should satisfy Section 3.1.1. Level access without thresholds is preferable.

d. Ground Surfaces: The slope of balconies and courtyards should not exceed 1:50.

e. Railings and Guards: Balconies and courtyards should have a railing or guard a minimum of 1070 mm above the floor/ground where the difference in level is more than 600 mm. They should be designed to allow clear vision below the rail for people seated in a wheelchair or mobility scooter, and incorporate pronounced color contrast between the railings and guards and the surrounding environment.

f. Doors: Balcony doors should open against a side wall or rail and comply with Section 3.2.9.

g. Protection from Weather and Environmental Factors: A variety of seating areas in sunny and shaded areas, and those which are protected from rain and wind should be provided.



h. Glazed panels: Where there is extensive use of glazed panels, the top and bottom edge should be defined with a contrasting color. If there are doors using glazed panels, the leading edge of the door should be of a color which contrasts with the surrounding environment and the controls and hardware should be of a contrasting color and comply with Section 3.2.9.

3.1.14.5 Other Considerations

- 2.2 Anthropometric Data
- 3.1.1 Ground Surfaces
- 3.1.3 Sidewalks, Pavements, Paths and Routes

Appendix B Materials and Finishes

Appendix B Texture and Color

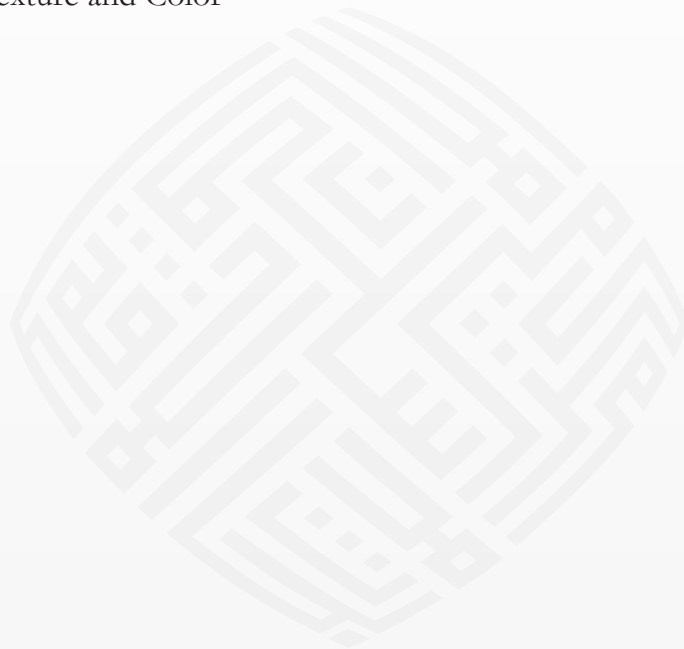

UABE TECHNICAL & DESIGN GUIDELINES

3.2 Interior Elements





3.2 INTERIOR ELEMENTS

3.2.1 Entrances

3.2.1.1 Design Considerations

Entrances should accommodate the full range of people who will use a facility. A separate accessible entrance does not promote the spirit of inclusion and should be avoided to respect the independence and dignity of people with disabilities. Canopies are recommended to make an entrance more obvious to a person with a cognitive disability or someone unfamiliar with the facility, as well as, to provide protection from the elements.



Figure 87: Entrances



Figure 88: Entrances

Entrance featuring a canopy, ramped and step access, as well as automatic doors activated by proximity scanning.



3.2.1.2 Application Guidelines

All entrances intended for use by staff and/or the public should comply with this section. In a renovation situation and where it is technically infeasible to comply fully, primary entrances and at least 50% of remaining staff and public entrances should comply with this section.

Each independent tenancy in a facility should be provided with its own accessible public entrance.

Secured public entrances, such as at police stations and courthouses, should comply with this section in addition to complying with Sections 3.5.7 and 3.5.8.

At least one entrance complying with this section should be provided in each of the following cases, where present: direct access between parking garages and facilities they serve, pedestrian tunnels, walkways and bridges used to connect spaces.

If only one entrance is provided into a facility or tenancy and it is also a service entrance, the entrance should comply with this section.

3.2.1.3 Technical Guidelines

a. General: Pedestrian entrances used by staff and/or the public should be served by an accessible route in compliance with Section 3.1.3.

b. Signage: Accessible entrances should include signage that clearly identifies them from a distance and that complies with Section 3.4.1. Entrances that are not accessible should display signage that provides direction to the closest accessible entrance. Directories and other information systems located at pedestrian entrances should comply with Section 3.4.1.

c. Entrance Protection: Accessible pedestrian entrances should be protected from the weather. The use of canopies or recessed entrances should be considered.

d. Illumination: Pedestrian entrances should be evenly illuminated to a minimum 150 lux at its exterior.

e. Illumination Transition: Immediately inside the entrance door there should be an illumination transition zone where people with visual impairments are able to adjust from a bright outdoors to a more dimly lit interior. The transition zone should have a level of illumination that averages the general exterior and interior levels at the entrance.



f. Rest and Waiting Areas: Rest and waiting areas containing seating that comply with Section 3.3.7 should be provided at pedestrian entrances used by the public.

g. Entrance Intercom: Door entry intercom systems should incorporate both visual and audible signals to indicate when the door has been released. Telephone intercoms provided at entrances should include visual and audible information to indicate when the other party has received the intercom call.

h. Entrance Finish: Entrance area walls and ceilings should be finished in a plain light matt color to help diffuse light and increase visibility.

i. Color Contrast: Accessible paths of travel leading to pedestrian entrances should be marked with color and texture contrast to the surroundings.

3.2.1.4 Other Considerations

2.2 Anthropometric Data

3.2.9 Doors

3.2.10 Windows, Glazed Screens and Sidelights

3.2.27 Gates, Turnstiles and openings

3.3.10 Controls and Operating Mechanisms

3.4.1 Signage

3.4.4 Information Systems

3.4.5 Card Access, Safety and Security Systems

Appendix B Illumination



3.2.2 Routes, Corridors and Access Aisles

3.2.2.1 Design Considerations

The ways individuals will use routes, corridors and access aisles should be reflected in the design. A corridor or aisle provides enough space for all people including those using wheelchairs, mobility scooters, pushing strollers or those travelling in pairs. The full range of motion of assistive devices should be considered in design plans; for example, while a corridor may be wide enough for a person to drive a mobility scooter in a straight line, it may not be possible to make a turn around a corner. The preferred minimum width for accessible routes is 1800 mm.

Strong color contrasts and/or tactile surfaces are recommended to provide navigational cues to people with visual impairments. All changes in level should be marked with edge definition.



Figure 89: Accessible Routes



Figure 90: Accessible Routes

Showing visible and detectable paths along interior routes.



3.2.2.2 Application Guidelines

All interior routes, corridors and access aisles should comply with this section. Exceptions: Accessible routes into and within these rooms and spaces are not expected to comply with these guidelines:

- service rooms
- lift machine rooms
- janitor rooms
- service spaces
- crawl spaces
- attic or roof spaces
- within portions of a floor area with fixed seats in an assembly occupancy where these portions are not part of an accessible route to spaces designated for wheelchair use; or
- within suites of residential occupancy except as noted in 3.5.9.

Where differences in floor elevations exist, interior accessible routes are permitted to include ramps, stairs, lifts or other elevating devices.

3.2.2.3 Technical Guidelines

a. Clear Width: The minimum clear width of accessible routes should be 1200 mm (Exception: At doors - refer to Section 3.2.9 for door requirements). When an accessible route is 1800 mm or less, unobstructed passing spaces measuring at least 1800x1800 mm should be provided at a distance of not more than 30 metres apart. Anywhere space is required for two wheelchairs to pass, the minimum width of the accessible route should be 1800 mm wide. (Figure 92)

b. Slope: The running slope of accessible routes should be no steeper than 1:25 (4%) and the cross slope should be no steeper than 1:50 (2%).

c. Edges: Where the floor elevation of an interior accessible route, corridor or access aisle is higher than an adjacent surface by 200-600 mm, the edge(s) of the accessible route should be protected by a color contrasting kerb that is at a minimum of 75 mm high (Figure 91). If the difference of floor elevation is greater than 600 mm, a guard that meets the requirements of the Kingdom of Saudi Arabia Building Code should be installed.

d. Change of Direction Signage: Directional signage that complies with Section 3.4.1 should be provided where a change in direction occurs along an accessible route and the intended destination is not clearly visible from that location.



e. Illumination: A minimum of 50 lux is required along interior accessible routes.

f. Slope: Accessible routes, corridors and access aisles with a running slope steeper than 1:25 are considered to be ramps and should be designed to comply with Section 3.2.3.

g. Rest Areas: All routes, corridors and access aisles should include level rest areas spaced not more than 50 metres apart in compliance with Section 3.3.7.

h. Surfaces: Wall surfaces along accessible routes should be non-abrasive from the floor to a minimum of 2000 mm above the floor. Use of highly reflective wall surfaces or wall and floor surfaces that produce high-glare should be avoided along accessible routes. Floor surfaces should not be heavily patterned or contain counter-intuitive patterning along accessible routes.

i. Color Contrast: Color contrast should be used between base boards, walls and doors to delineate edges along the access route. Walls located at the end of corridors should be contrasted in color or brightness from adjacent walls and floor.

j. Line-up or Queuing Areas: Line-up and queuing areas should comply with Section 3.3.2.

3.2.2.4 Illustrations



Figure 91: Edge Protection

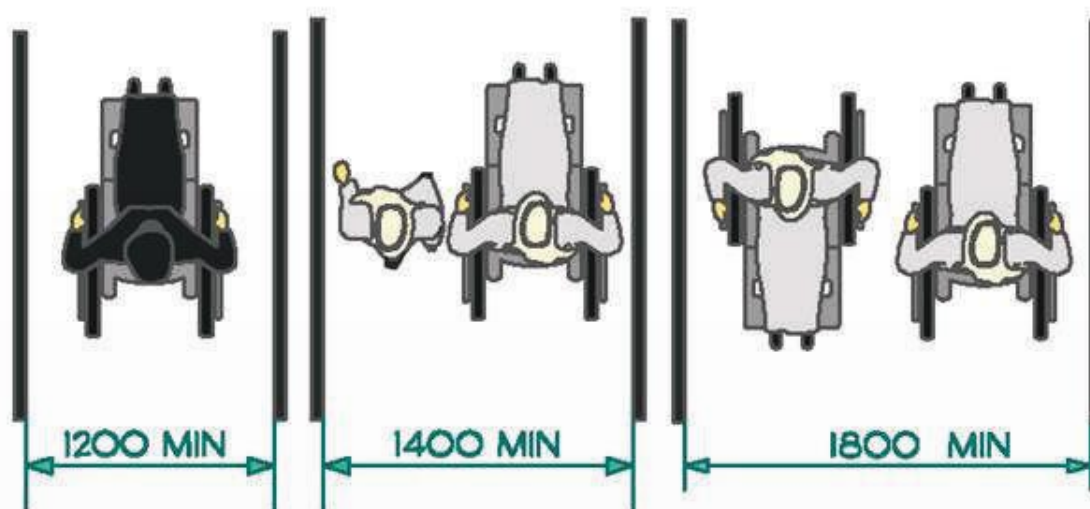

Figure 92: Access Widths

3.2.2.5 Other Considerations

- 3.2.3 Interior Ramps
- 3.2.25 Ground Surfaces
- 3.3.4 Raised Platforms and Stage
- 3.4.1 Signage
- 3.4.6 Detectable Warning Surfaces
- 3.2.26 Overhanging and Protruding Objects

Appendix B Glare and Light Sources

Appendix B Illumination

Appendix B Materials and Finishes

Appendix B Texture and Color



3.2.3 Interior Ramps

3.2.3.1 Design Considerations

Ramps, often synonymous with wheelchair accessibility, can be dangerous, problematic and difficult to use if not design properly. The space required for well design ramps can make them challenging to integrate into a facility. Designs that minimize the need for ramps are preferred. Where a change in level already exists or cannot be avoided, a well designed ramp can provide access for those using wheelchairs, mobility scooters, moving packages or a trolley or pushing strollers.

The usefulness and safety of a ramp is determined by careful design. Ascending a steep ramp is difficult when using a wheelchair and can increase the risk of the chair tipping backwards. Descending a steep ramp can also be dangerous. Any cross slope should be avoided as it will increase the effort required to negotiate the ramp. Manoeuvring space at the top and bottom are important usability factors for a ramp. Providing level landing areas at intervals along a long ramp allow for brief rest areas for people with lower stamina.

Important safety features include handrails, textured surfaces, and edge protection. Some people have difficulty using slopes so stairs should also be provided in where ramps are necessary.

3.2.3.2 Application Guidelines

Any part of corridor, route or access aisle that has a running slope steeper than 1:25 (4% slope) is a ramp and should comply with this section.

Where ramps are used, an adjacent set of stairs should also be considered.

3.2.3.3 Technical Guidelines

a. General: Accessible ramps should be located on accessible routes in compliance with Section 3.1.3.

b. Running Slope: The running slope of a ramp should be between 1:16 and 1:25. In a renovation situation, where it is technically infeasible to provide a ramp with a running slope between 1:16 and 1:25, a running slope that does not exceed 1:12 may be used. *(Figure 93 and 94)*

c. Horizontal Length of a Ramp: The maximum horizontal length of a ramp, measured between ramp landings, should not exceed 9 meters. *(Figure 93)*

d. Cross Slope: The maximum cross slope of ramp surfaces should be 1:50.



e. Ramp and Landing Surfaces: Ramp and landing surfaces should be firm, stable, and slip-resistant.

f. Landing Slopes: Level landing areas should be provided at the top and bottom of all ramps and where the ramp changes direction. The maximum slope in any direction on a landing should be 1:50.

g. Landing Size at Top and Bottom: The top and bottom landings should be a minimum of 2100 x 2100 mm. In a renovation situation, where creating a suitably sized landing is technically infeasible, the required landing size may be reduced to 1800 x 1800 mm. (Figures 93 and 94)

h. Intermediate Landing Size: Intermediate landings at the switchback of a U-shaped ramp (180° turn), should not be less than 1800 mm in deep and not less than 2400 mm wide. Where an intermediate landing is located at the corner of an L-shaped ramp (90° turn), the width and depth of the landing should not be less than 2100 mm. In a renovation situation, where creating a suitably sized intermediate landing at the corner of an L-shaped ramp (90° turn) is technically infeasible, the required landing size may be reduced to 1800 x 1800 mm. Where an intermediate landing occurs on a straight ramp, the depth of the landing should not be less than 1800 mm. (Figure 93)

i. Obstructions at Landings: Where windows or doors open across a ramp landing surface, they should not obstruct movement along the ramp or on the landing.

j. Curved Ramps: Curved ramps are difficult for wheelchair manoeuvring and should not be used as part of an accessible route.

k. Edge Protection: Edges of ramps and landings should be protected with a wall or a guard on either side of the ramp. (Figure 96)

l. Ramp and Landing Guards: Where a guard is provided on a ramp or ramp landing, it should comply with the requirements of the Kingdom of Saudi Arabia Building Code. In addition, there should be provided a kerb of at least 75 mm above the ramp on any side where no solid enclosure or guard is provided; Railings or other barriers that extend to within 50 mm of the finished ramp should also be provided, or have a minimum kerb 75 mm above the ramp surface. (Figure 96)

m. Ramp Handrails: A ramp run that has a rise greater than 150 mm should have handrails located on both sides of the ramp that are mounted at a uniform height above the ramp floor. Handrails should be continuous around the inside edge of a U-shaped or L-shaped ramp. Handrail should extend horizontally at least 300 mm onto the top and bottom landings and then return to the wall, floor, or post (Figure 95). Both an upper and lower handrail should be provided on each side of the ramp,



with the upper handrail located at 875-925 mm and the lower handrail located 600-750 mm above the ramp surface. Handrails should comply with Section 3.3.13. A tactile indicator in the form of a domed button should be provided on the top of the handrail located 140-160 mm from the end of the handrail and before an intermediate landing to indicate an upcoming change in slope. Handrails should incorporate a pronounced color contrast, to differentiate them from the surrounding surfaces.

n. Distance between Handrails: The clear width between ramp handrails should be 950-1100 mm apart. On wide ramps, where intermediate handrails are required, the distance between at least one set of handrails should be 950-1100 mm and located adjacent to one side of the ramp.

o. Handrails in Aisle Ways for Fixed Seating: Where a ramp serves as an aisle way for fixed seating, such as in a performance venue, a ramp handrail is only required on any non seating sides adjacent to the ramp.

p. Illumination: The full run of the ramp including all landings should be evenly illuminated to a minimum of 100 lux.

q. Detectable warning surfaces: A detectable warning surface should be provided at the top of each ramp run. It should begin 300 mm back from the start of the ramp run, be 900 deep, and extend across the full width of the ramp. The detectable warning surface should have color, texture, resiliency, be a contrasting color from the surrounding surface and should comply with Section 3.4.8.

r. Color contrasting strips: Ramps should have a color contrasting strip 40-60 mm wide across the full width of the ramp at the top and bottom of the ramp and at landings where there is a change in slope.

s. Signage: Where a ramp is provided as a part of an accessible route leading to a building entrance and the intended destination is not clearly visible from that location, signage in compliance with Section 3.4.1 should be installed to indicate the location of the accessible ramp and the entrance.



3.2.3.4 Illustrations

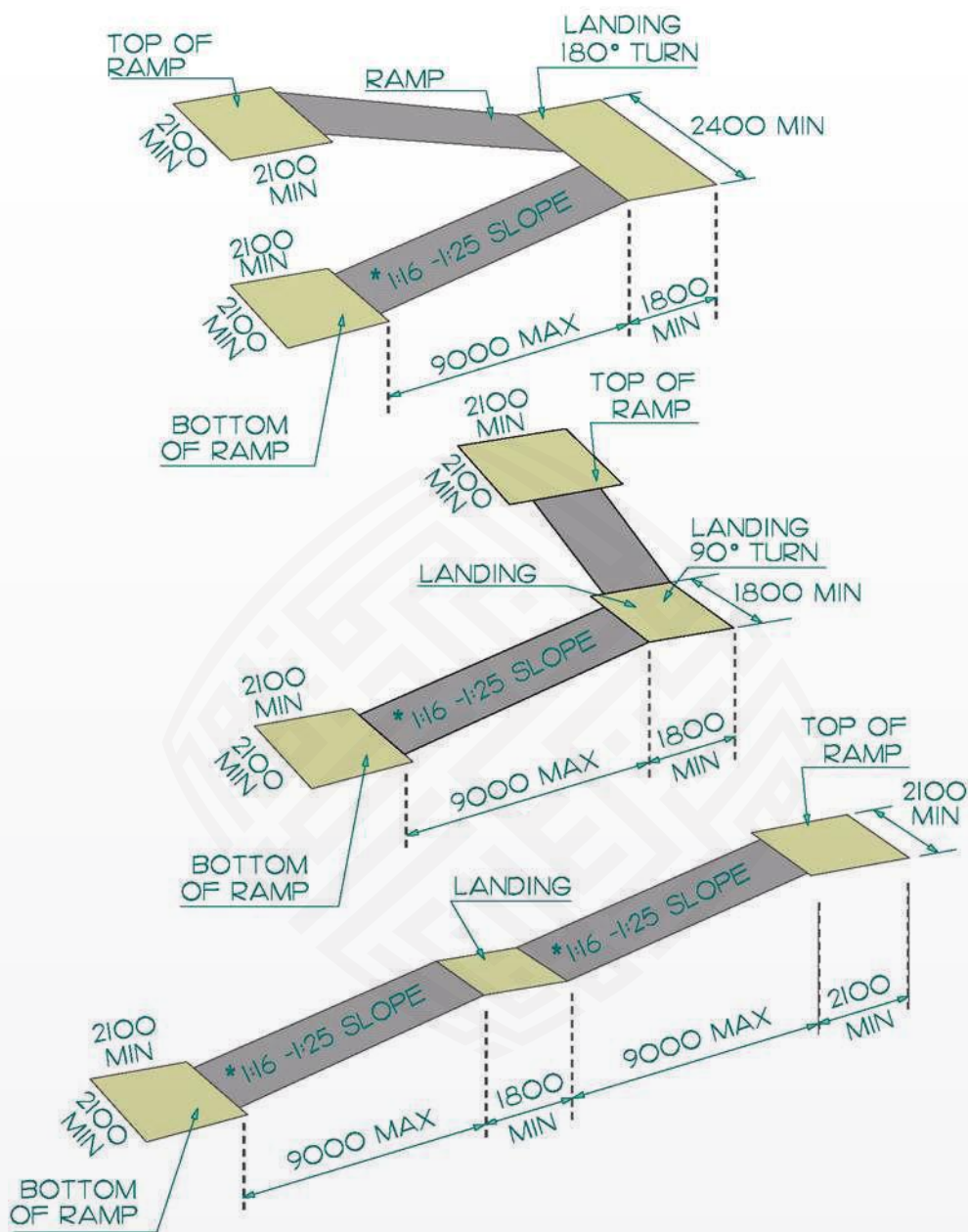

Figure 93: Minimum Ramp Landing Dimensions

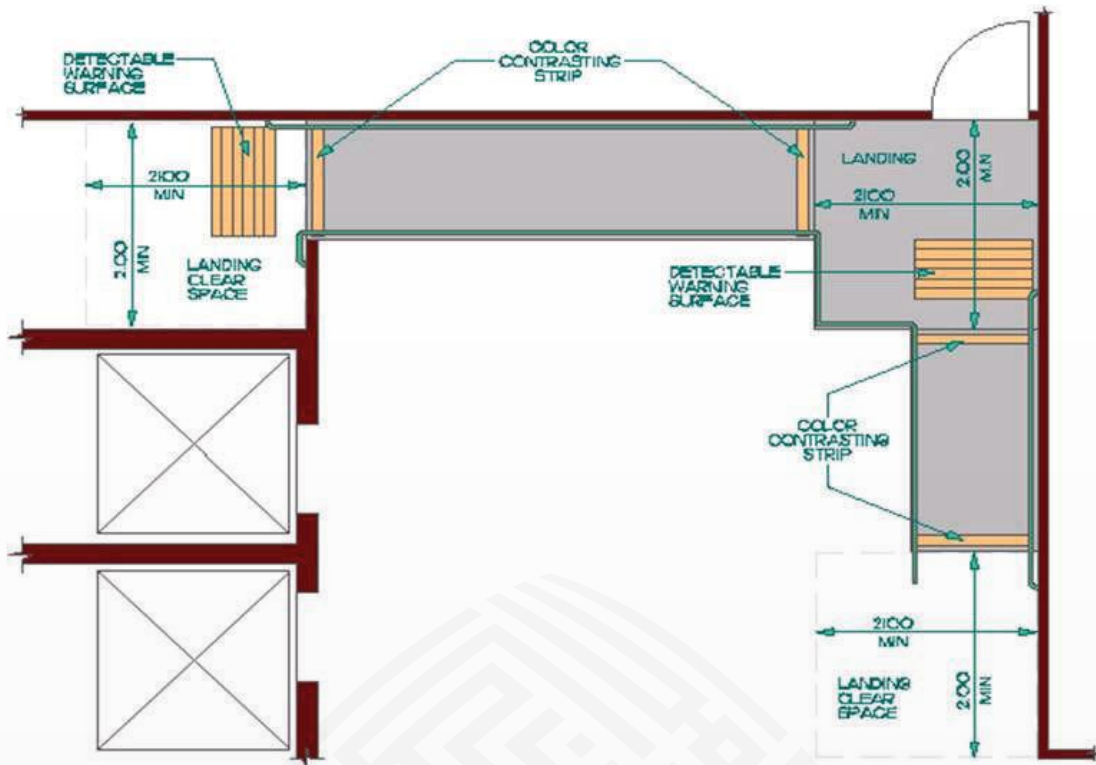

Figure 94: Ramp Criteria

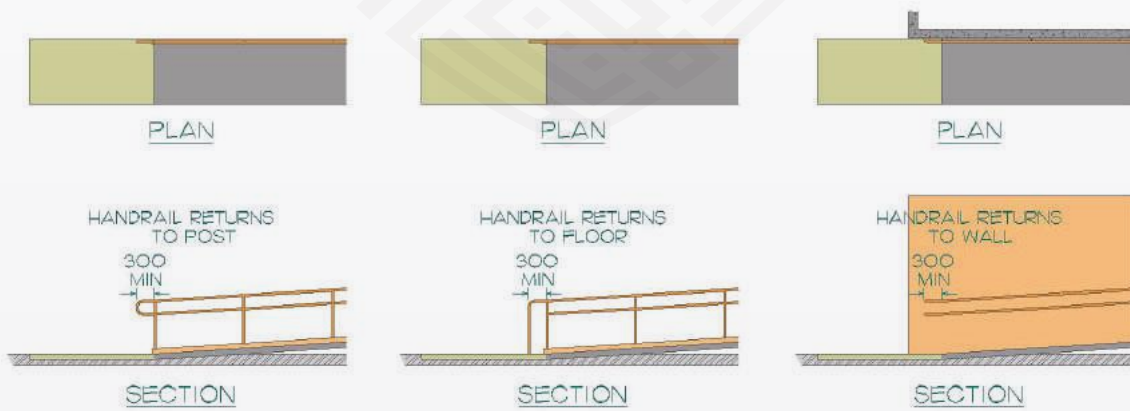
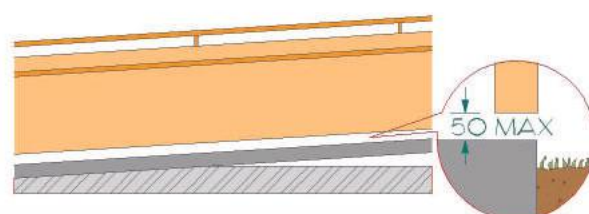
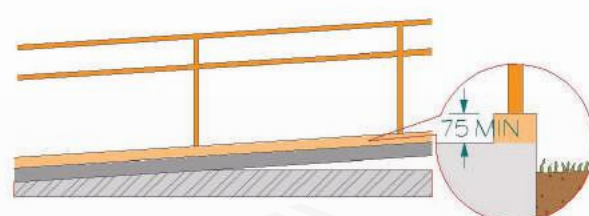

Figure 95: Horizontal Handrail Extensions



ELEVATION



ELEVATION

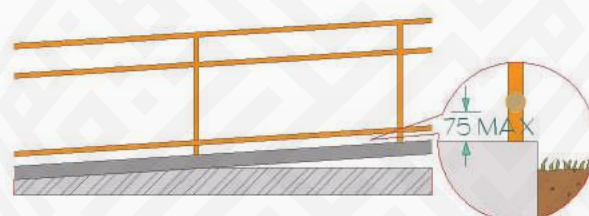

ELEVATION

Figure 96: Edge Protection at Ramps

3.2.3.5 Other Considerations

- 2.2 Anthropometric Data
- 3.2.9 Doors
- 3.2.25 Floor Surfaces
- 3.3.10 Controls and Operating Mechanisms
- 3.3.13 Handrails
- 3.4.7 Signage
- 3.4.6 Detectable Warning Surfaces

- Appendix B Glare & Light Sources
- Appendix B Illumination
- Appendix B Materials and Finishes
- Appendix B Texture and Color



3.2.4

Interior Stairs

3.2.4.1 Design Considerations

Stairs can be challenging, especially to children, seniors, people with prosthetic devices or those using canes. Although poorly designed stairs are problematic for all individuals, they are especially hazardous to people who have trouble walking or difficulties with balance.

Visual and tactile cues should be incorporated in stair design to warn people with a low or no vision that they are approaching a set of stairs – similarly, color contrast should be provided at stair nosings. In addition, the appropriate design of handrails is an important safety feature for all users.



Figure 97: Stair Configuration

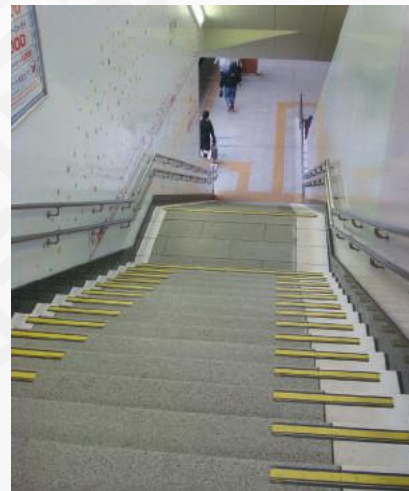

Figure 98: Stair Configuration

Showing an example of a color contrast at nosing and detectable tactile strip at top and bottom.



3.2.4.2 Application Guidelines

Where new stairs are planned at interior locations, they should comply with this section.

Where existing stairs are to be renovated, the dimensions of existing steps and landings are not expected to comply with these guidelines - however all other design requirements should be met.

3.2.4.3 Technical Guidelines

a. Treads and Risers: Riser heights (rise) and tread depths (run) of stairs should be uniform. The rise should not exceed 180 mm high or be less than 125 mm high. The stair run, measured from riser to riser, should be no more than 350 mm deep and no less than 280 mm deep. Open risers should be avoided on stairs that are part of an accessible route. Stair treads and landings should be finished with non slip material. *(Figure 100)*

b. Nosing: When stair nosings are incorporated in a stair design, they should project no more than 40-60 mm beyond the riser face, they should extend the full width of the tread and be no more than 25 mm in height. Stair nosing should possess no abrupt underside and should have a curved or bevelled leading edge with a 6-10 mm radius. Stair nosings should be sloped to the riser at an angle not less than 60 degrees to the horizontal. All stair treads, including nosings, should be illuminated with a minimum of 100 lux, use slip-resistant materials and make use of color contrast to differentiate between the horizontal and vertical surfaces. *(Figure 101)*

c. Detectable warning indicators: Stairs should incorporate detectable warning surfaces at the top and bottom of all stair flights. Detectable warning surfaces should extend the full width of the stair, have a depth of 600-900 mm, commence 300 mm from the edge of the stair, and should also comply with Section 3.4.6.

d. Stair Handrails: Dual height handrails should be installed on both sides of interior stairs and should be continuous along the inside edge of any stairs that contain a switchback. The upper handrail should be located at a uniform height of 875-925 mm, measured vertically and directly above the stair nosing, and the lower handrail located at a uniform height of 600-750 mm also measured vertically and directly above the stair nosing. Handrails should extend past the top and bottom of all stair flights. Handrails at the bottom of stairs should continue a distance of one tread depth beyond the first riser, then horizontally for not less than 300 mm, at the applicable height required above. Handrails at the top of stairs should continue horizontally for a distance not less than 300mm, at the applicable height required above. After extending at the top and bottom of stairs, handrails should then return to the wall or post in



a way that does not impede or pose hazards to pedestrian travel. Where wide stairs are designed, intermediate handrail/s should be provided. Contrasting colors should be used to distinguish handrails from the surrounding environment and surfaces. In addition, handrails should comply with Section 3.3.13.

e. Illumination: Stairs and stair landings should be evenly illuminated to a level of at least 100 lux.

g. Headroom: Headroom over stairs should be at least 2100 mm measured vertically from the leading edge of the stair nosing.

h. Windows and Doors: Windows and doors may open onto a landing provided they do not obstruct circulation or subtract from required clear widths.

i. Circular Stairs: Circular stairs are not considered to be part of an accessible route and should be avoided.

k. Patterned Surfaces: Surfaces containing a large degree of patterning or counter-intuitive patterning can cause disorientation and confusion, and should be avoided around stairs.

3.2.4.4 Illustrations

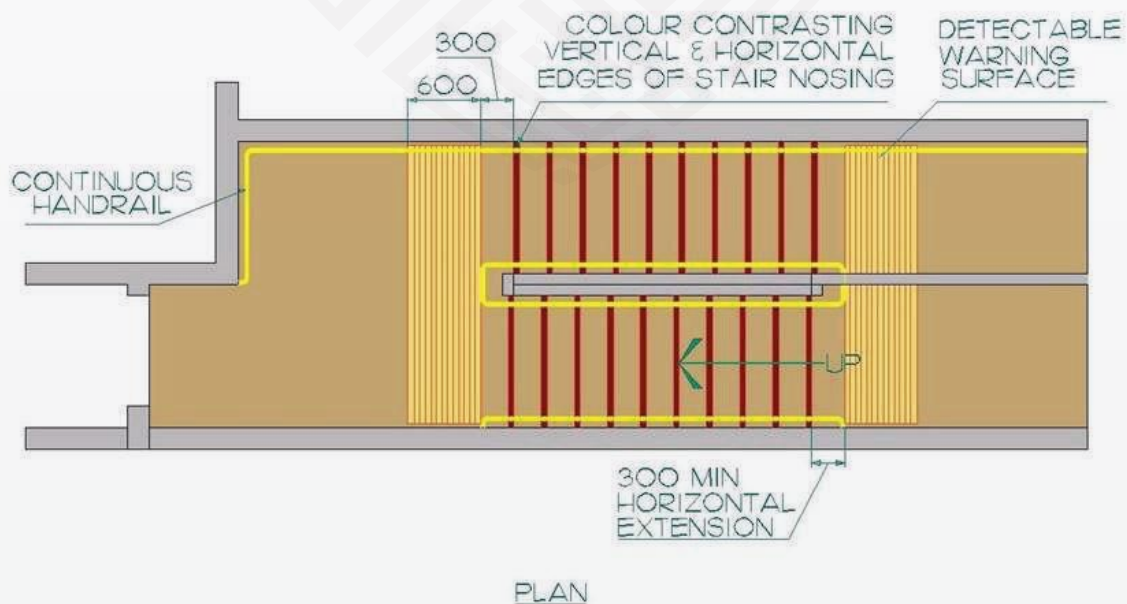

Figure 99: Stair Design Criteria

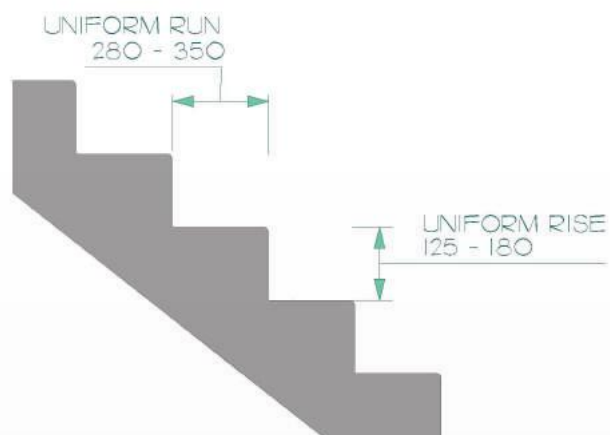

Figure 100: Stair Tread Criteria

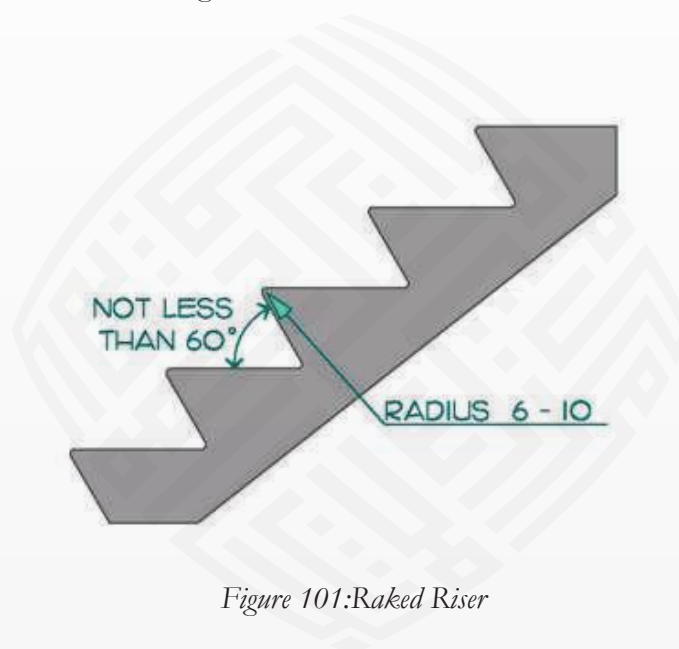

Figure 101: Raked Riser

3.2.4.5 Other Considerations

- 2.2 Anthropometric Data
- 3.2.9 Doors
- 3.2.25 Floor Surfaces
- 3.3.13 Handrails
- 3.4.1 Signage
- 3.4.6 Detectable Warning Surfaces

- Appendix B Glare and Light Sources
- Appendix B Illumination
- Appendix B Materials and Finishes
- Appendix B Texture and Color



3.2.5 Escalators

3.2.5.1 Design Considerations

For people who have difficulty with timing, agility or balance, stepping on and off an escalator can be an intimidating challenge. All steps should be marked with color contrasting strips to help users discern step positions and judge the escalator's speed. In addition, detectable warning surfaces should be placed in front of entrances and exits to alert pedestrians to an escalator's presence, especially people with visual impairments.

3.2.5.2 Application Guidelines

Where escalators are installed, they should comply with this section.

3.2.5.3 Technical Guidelines

a. Alternative Accessible Route: Escalators are not considered to be a part of an accessible route, an alternate accessible route, complying with Section 3.2.2, should be provided in proximity to escalators.

b. Color Contrast: The tread edges and nosing of escalators should be marked with strong/high color contrasts.

c. Detectable Warning Surfaces: Detectable warning surfaces that comply with Section 3.4.6 should be provided at the head and foot of escalators.

d. Surface: Matte finishes should be used on the escalator tread surfaces to minimize reflection and glare.

e. Lighting: Escalators should be evenly illuminated at a minimum of 200 lux using low-glare light sources.

3.2.5.5 Other Considerations

2.2	Anthropometric Data	Appendix B Glare and Light Sources
3.2.25	Floor Surfaces	Appendix B Illumination
3.4.1	Signage	Appendix B Materials and Finishes
3.4.6	Detectable Warning Surfaces	Appendix B Texture and Color



3.2.6 Lifts

3.2.6.1 Design Considerations

Lifts may be considered part of an accessible route and should incorporate appropriate accessible features to meet the requirements of the wide range of the people who will use them.

The design of buttons should anticipate a range of abilities in reach, dexterity and vision. Individuals with a visual impairment require audible cues that identify floor levels and the direction of travel. Doors should be equipped with a delay to allow people using mobility devices ample time to reach, enter or exit the lift car. A mirror is recommended to assist individuals using mobility devices as they back out a lift where there is insufficient space to turn around.



Figure 102: Lift

Showing an example of lowered and large interior call buttons, and color definition on the floor.



Figure 103: Lift Control Panel

Showing an example of a lift control panel featuring color contrast and tactile bilingual text, buttons and symbols.

3.2.6.2 Application Guidelines

Every level in multi-storey facilities, including mezzanines, serviced by a passenger lift should comply with this section.

When more than one lift is provided, each passenger lift should comply with this section.

Freight lifts are exempt from the requirements of this section, unless the only lift provided is both a passenger and freight lift used by the public and employees.

Lift access is not required:

1. in lift pits, lift penthouses, mechanical rooms, and piping or equipment catwalks;
2. when accessible ramps in compliance with 3.2.3 are used in lieu of a lift;
3. to levels of fire stations and ambulance stations not served by grade-level entry, which do not contain public use facilities; and
4. when platform lifts (wheelchair lifts) in compliance with 3.2.7 and applicable Codes, are used in lieu of a lift. Platform lifts may be used only under the following conditions:
 - to provide an accessible route to a performing area in an assembly occupancy;
 - to comply with wheelchair viewing position line-of-sight and dispersion requirements of 3.3.3;
 - to provide access to incidental occupied spaces and rooms that are not open to the general public and which house no more than five persons, including, but not limited to, equipment control rooms and projection booths; and
 - to provide access to raised judges' benches, clerks' stations, speakers' platforms, jury boxes and witness stands or to depressed areas, such as the well of a court.



3.2.6.3 Technical Guidelines

a. General: Accessible lifts should be located on accessible routes that comply with Section 3.2.2. Where a lift serves only two floors, it should be provided with a system to sense entry into the cab and to move automatically to the next floor without the need for manual activation. Lifts should comply with all applicable current standards for installation.

b. Signage: Accessible lifts should be labelled with signage that complies with Section 3.4.1.

c. Clear Width of Doors: The clear width between lift doors, when in the open position, should be a minimum of 900 mm. In a renovation situation and where it is technically infeasible to provide the required minimum clear width, the minimum clear width between doors may be reduced to 850 mm.

d. Color Contrast: Lift doors should be color contrasted to adjacent surfaces. Lift sills should be color contrasted to adjacent floor surfaces.

e. Hoist Way Entrances Floor Designations: Floor designation characters should be provided on both exterior door jambs in raised characters and Braille. Characters should be at least 50 mm high, should protrude a minimum of 0.75 mm above the jamb surface and be fixed at 1475-1525 mm above the floor, measured to the centerline of the characters. (Figure 105)

f. Doors and Opening Time: Lift doors should slide horizontally, and open/close automatically. Lift doors should remain open for a minimum of 8 seconds under automatic operation with an optional manual close button to allow users to override the waiting time.

g. Lift Levelling Device: Lifts should incorporate a two-way automatic-levelling device to maintain the cab floor elevation to within ± 13 mm of the floors that it serves.

h. Door Re-opening Device: Doors should include a door re-opening device that will automatically re-open the lift door and an adjacent hoist way door to a minimum of 900 mm. Door re-opening devices should activate automatically without contacting obstructions that are between 100-150 mm and 700-760 mm above the floor.

i. Interior Cab Dimensions: The lift cab interior width, measured between opposing side walls should be a minimum of 1725 mm wide, measured between the rear wall and door, excluding return panels, a minimum of 1525 mm deep (Figure 104). In high occupancy public facilities, such as arenas, libraries or entertainment complexes, the minimum interior width of the elevator cab should be increased to 2025 mm. In renovation situations where it is technically infeasible to provide the required cab dimensions, a Limited Use/Limited Application (LU/LA) elevating device may be used with a minimum platform length of 1525 mm.



j. Cabs Floors: Cab floors should be firm and slip-resistant.

k. Handrails: Handrails should be installed on all cab walls that do not have a door. Handrails should be mounted at a height of 800-900 mm above the cab floor and should have a 40-45 mm space between the rail and the cab wall surface.

l. Lift Interior Controls: Lift controls located at the interior of the cab should be positioned to permit easy access for people in wheelchairs. Floor register button design may be raised, flush or recessed, and should have a minimum size of 19 mm across measured in any direction. Where flush or recessed buttons are used, the depth for activation or the depth of the recess should not exceed 10 mm. Lift control buttons should be located between 900-1200 mm above the lift floor, measured to the centerline of the button. When activated, each call should be confirmed with visual and audible indicators and when a call is answered, the visual indicator should be extinguished. (*Figure 106 and 107*)

m. Control Markings: All controls located at the interior of the cab should include markings consisting of Grade 2 Braille in addition to raised characters for letters, numbers, and standard cab symbols. Markings should be located to the immediate left of the buttons to which they apply, and measure a minimum of 16 mm across in any direction. Raised characters only, are permitted to be located on the control button surface. Raised characters should project from the surface at least 0.75 mm.

n. Emergency Car Controls and Door-Operating Buttons: Emergency car controls and door-operating buttons should be grouped together at the bottom of the control panel.

o. In Cab Indicator: An illuminated display should be provided in the lift cab that displays the floor level that the lift cab is stopped at or passing. The illuminated display should have characters that are at least 16 mm high and are displayed against a color contrasted background.

p. Illumination: The car controls, landing sill, and floor should be illuminated by a minimum of 200 lux, measured at the control, sill, and floor levels. The illumination level of cars should be equivalent to adjacent lobby spaces.

q. Hall Call Buttons: Lift call buttons located at the exterior of the lift cab (Hall Call buttons) should measure a minimum of 20 mm across in any direction. Hall call buttons should be mounted one above the other, with the centre line of the configuration between 900-950 mm above the floor. (*Figure 105*)

r. Hall Visual Indication: An illuminated display should be provided at the exterior of the lift cab, that displays the floor level where the lift cab is stopped or passing.



s. Hall or In-Car Lanterns: Lanterns should be provided at the exterior and interior of lift cabs that display the lifts direction of travel. Lanterns should be installed at a minimum height of 1825 mm above the floor. Lanterns should measure a minimum of 60 mm in any direction.

t. Audible Signals and Voice-Annunciation: An audible signal should be provided in the hall when a lift makes a stop at a floor level. In addition, voice-annunciation technology should be used to announce floors and direction of travel within lift cars.

u. Emergency Call System: All lifts should be linked directly to a monitored location through an emergency call system featuring two-way communication. Symbols adjacent to the emergency call buttons should measure a minimum of 35 mm high and project from the surface a minimum of 0.75 mm; permanently attached plates are acceptable. When a handset is provided as part of the emergency call system, the length of the cord connecting the handset to the panel should be a minimum of 750 mm in length. Additionally the handset should incorporate a receiver that generates a magnetic field in the area of the receiver cap, and the handset should have a volume control. Where the emergency call system is located in a closed compartment, the compartment door and hardware should conform to Section 3.3.10. The emergency call system should be capable of functioning without voice communication.

v. Mirrors: When mirrors or similar materials are installed inside lift cabs, they should not be located lower than 2000 mm above the floor. Mirrors or similar materials should not be installed on the wall opposite the door, unless any interior cab dimension is less than 1525 mm; then an angled mirror should be provided on the wall opposite the door to assist people using mobility devices to back out.



3.2.6.4 Illustrations

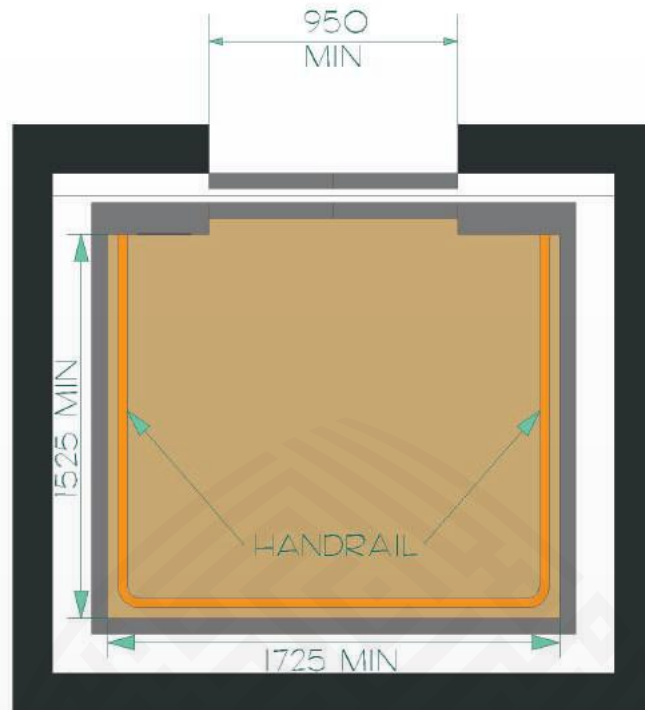

Figure 104: Lift Dimensions

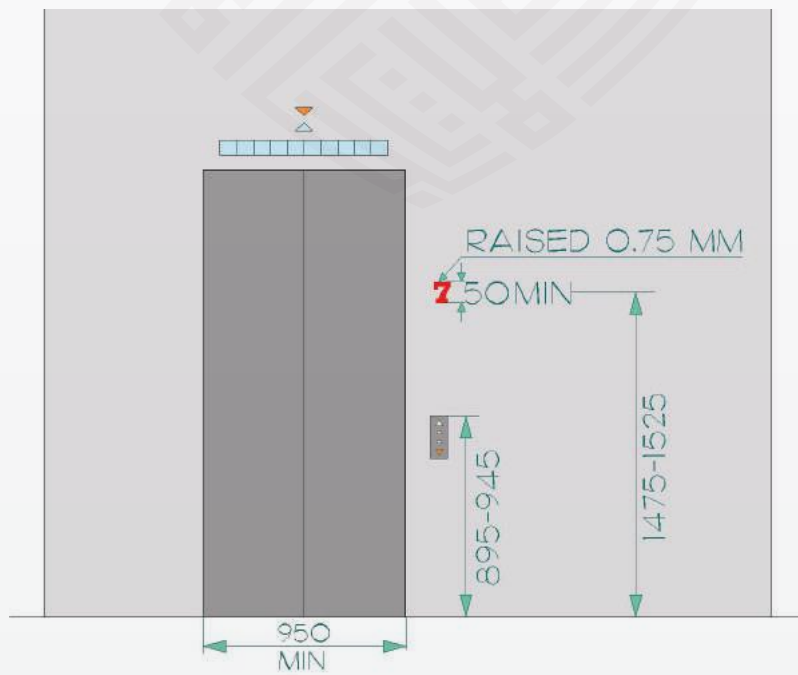

Figure 105: Lift Entry

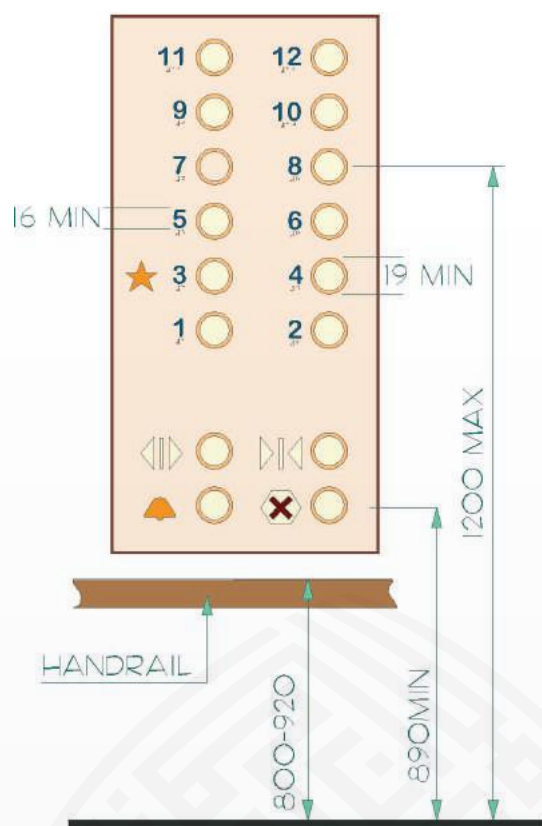

Figure 106: Control Panel

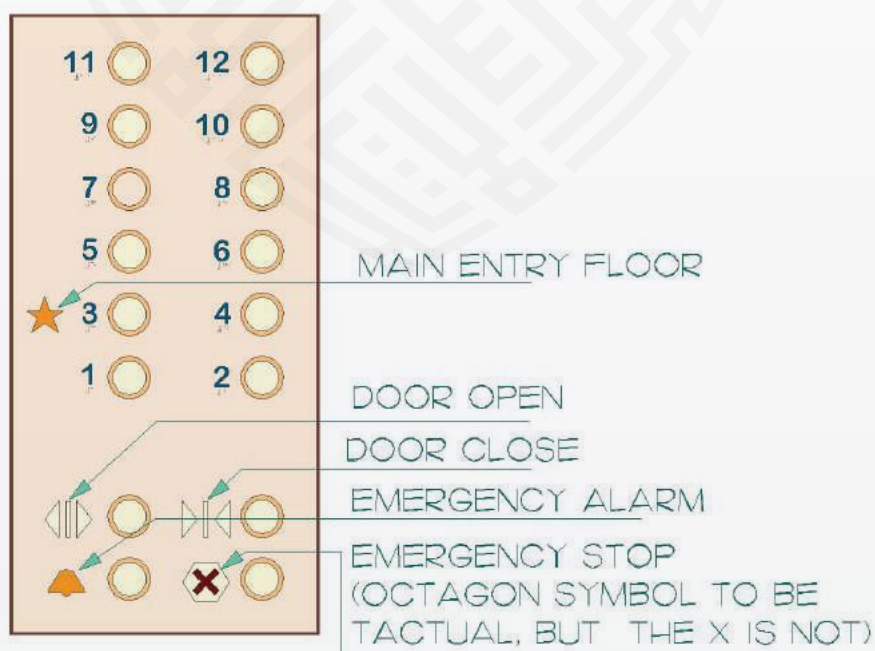
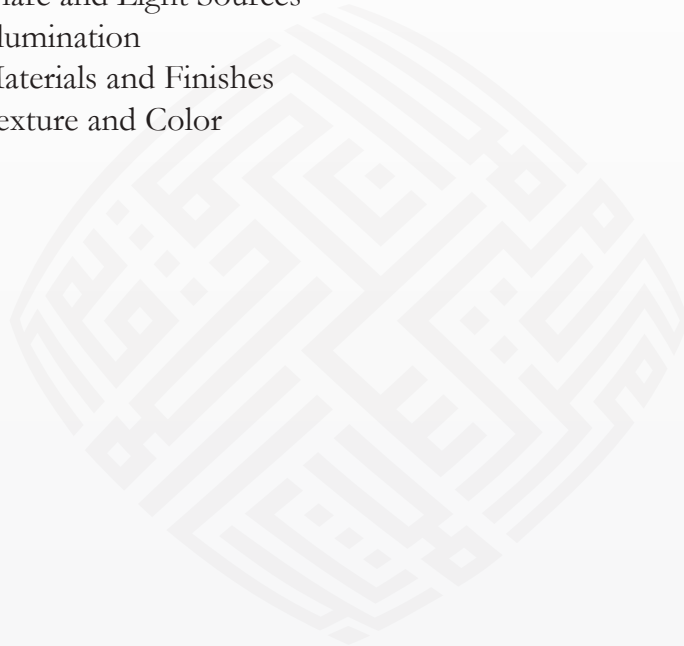

Figure 107: Tactile Symbols



3.2.6.5 Other Considerations

- 2.2 Anthropometric Data
 - 3.2.7 Inclined and Vertical Platform Lifts
 - 3.2.9 Doors
 - 3.2.25 Floor Surfaces
 - 3.3.10 Controls and Operating Mechanisms
 - 3.3.13 Handrails
 - 3.4.1 Signage
 - 3.4.3 Public Address Systems
 - 3.4.5 Card Access, Safety and Security Systems
-
- Appendix B Glare and Light Sources
 - Appendix B Illumination
 - Appendix B Materials and Finishes
 - Appendix B Texture and Color





3.2.7 Inclined and Vertical Platform Lifts

3.2.7.1 Design Considerations

Passenger lifts that can be accessed by all facility users are preferred over inclined or vertical platform lifts. Platform lifts segregate people with disabilities and often limit space at entrance and stair locations. They are often controlled by key operation, meaning that the independence of users is compromised. Therefore, ramping or integrated passenger lift access should be used whenever possible.

If there are no suitable alternatives, inclined and vertical platform lifts can be considered as a strategy to accommodate people with mobility impairments. However, it should be noted that inclined and vertical platform lifts may not accommodate the spatial requirements of larger mobility devices, such as mobility scooters.



Figure 108: Platform Lift

Showing an example of a lift positioned adjacent to the stairs with independent user operations.



3.2.7.2 Application Guidelines

Inclined platform lifts, vertical platform lifts and Limited Use/Limited Application (LU/LA) lifts should comply with this section. A LU/LA lift, or other accessible lifting device, may be used only where it is technically infeasible to install a passenger lift in compliance with Section 3.2.6 or a ramp in compliance with Section 3.2.3.

3.2.7.3 Technical Guidelines

a. General: Platform lifts should be located on an accessible route that complies with Section 3.2.2. The platform lift should comply with all current applicable standards relating to installation.

b. Signage: Platform lifts should be identified with signage that complies with Section 3.4.1.

c. Platform Size: The minimum platform size of a lift should be 890 mm wide and 1525 mm deep.

d. Floor Finishes: Floor finishes used on lift platforms should be slip resistant and should comply with Section 3.2.25.

e. Guards: Safety guards should be provided along all edges of lift platforms.

f. Doors: Doors to platform lifts should be designed to permit unassisted entry, operation, and exit from the lift and should comply with Section 3.2.9.

g. Controls and Operating Mechanisms: Lift controls should be located between 900-1200 mm above the lift floor, measured to the centerline of the control. Controls and operating mechanisms should not require keys to be operated and should comply with Section 3.3.10.

h. Emergency Call System: Platform lifts should be linked directly to a monitored location through an emergency call system featuring two-way communication. When a handset is provided as part of the emergency call system, the length of the cord connecting the handset to the panel should be a minimum of 750 mm in length. Where the emergency call system is located in a closed compartment, the compartment door and hardware should conform to Section 3.3.10. The emergency call system should be capable of functioning without voice communication.



3.2.7.4 Illustrations

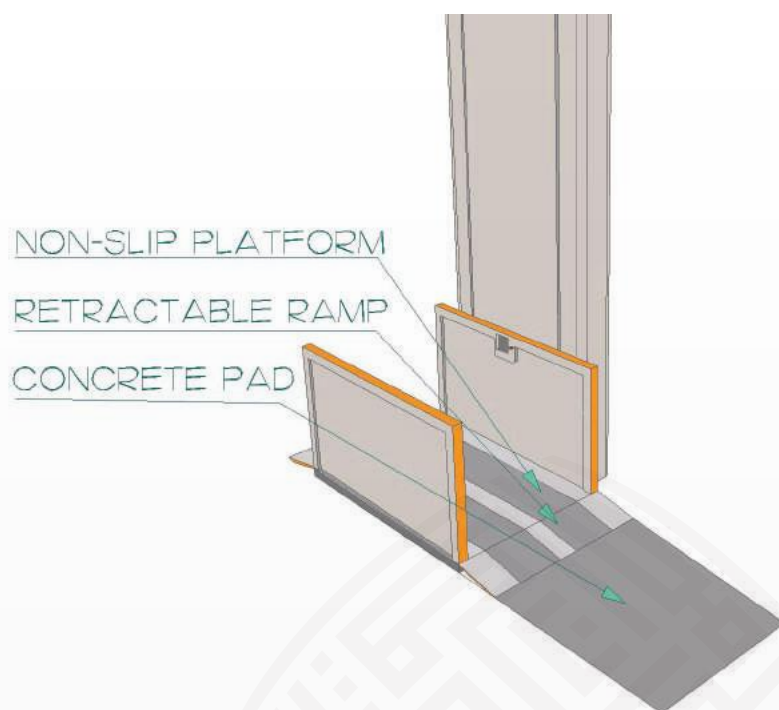

Figure 109: Vertical Platform Lift

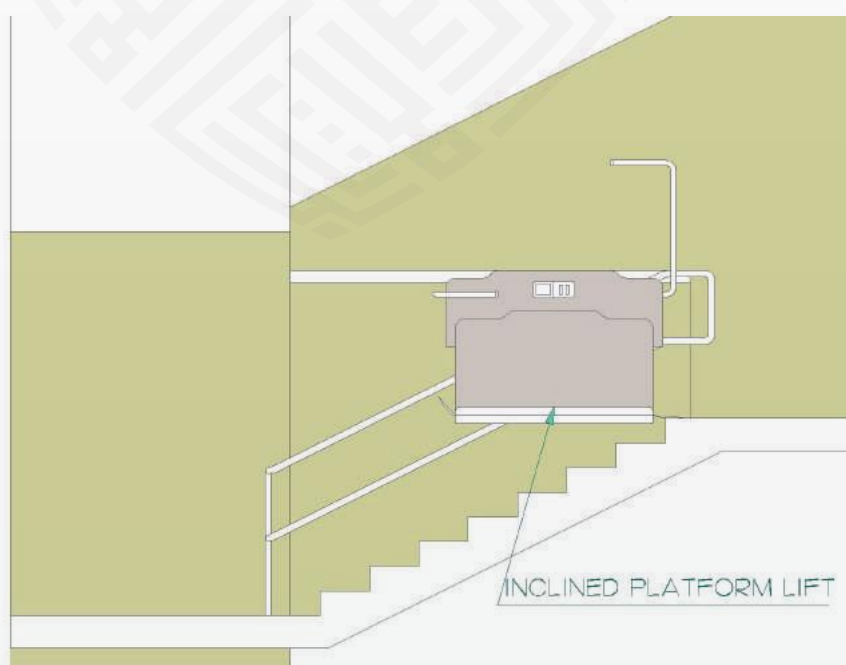

Figure 110: Inclined Platform/Stair Lift



3.2.7.5 Other Considerations

- 2.2 Anthropometric Data
- 3.2.6 Lifts
- 3.2.9 Doors
- 3.2.25 Floor Surfaces
- 3.3.10 Controls and Operating Mechanisms
- 3.3.13 Handrails
- 3.4.1 Signage
- 3.4.3 Public Address Systems
- 3.4.5 Card Access, Safety and Security Systems

- Appendix B Glare and Light Sources
- Appendix B Illumination
- Appendix B Materials and Finishes
- Appendix B Texture and Color



3.2.8 Moving Walks

Note: This section of the guidelines is substantially based upon Clause 6.2 of ASME A17.1/CSA B44, Safety Code for Lifts and Escalators.

3.2.8.1 Design Considerations

Moving walks increase walking speeds and reduce the challenges of traveling long distances. The design of moving walks should account for people with mobility impairments who used non-motorised mobility devices, elderly persons, people who are blind and people with low vision.

The angle of an inclined moving walk should fall within a safe range to protect people with limited balance and to prevent wheelchairs and other mobility devices from tipping backwards.

Audio cues for entry and exit points should be present for people with visual impairments. Similarly, visual reminders of an entrance or exit should be available for people who are deaf, deafened or hearing impaired, as well as people who are distracted or not paying attention.



Figure 111: Inclined Walk

Showing a front view of inclined walk, Bangkok International Airport.



Figure 112: Inclined Walk

Showing a side view of inclined walk, Bangkok International Airport.

3.2.8.2 Application Guidelines

Moving walks should comply with this section.

Moving walks should be installed as part of interior circulation routes where pedestrian travel distances are greater than 30 meters long, such as within terminal buildings.

3.2.8.3 Technical Guidelines

a. General: Moving walks should be on an accessible route complying with Section 3.2.2. Moving walks should comply with current applicable standards relating to installation.

b. Width: The minimum clear width along a moving walkway should be 1000 mm.

c. Handrails: Handrails should be provided along both sides of the moving walk and be located between 850-1100 mm above the moving walk floor surface. Moving walk handrails should move at the same speed as the floor and should extend at least 300 mm beyond the entry and egress comb plates located at the ends of the moving walk. Handrails should be color-contrasted to their surroundings.

d. Height: A minimum clear height of 2100 mm should be provided along the full length of the walk.



e. Angle of Inclination: The angle of inclination for moving walk floors should not be more than 3-degrees to the horizontal at any point within 900 mm of the entrance or exit of the moving walk, and should not be more than 4-degrees at any other point along the length of the walk.

f. Speed: The speed of moving walkways should be between 0.5–0.75 meters per second.

g. Visual and Audible Warnings: Moving walks should have visual and audible warning signals provided that are identifiable before entering and exiting the walkway.

h. Detectable Warning Surfaces: A color-contrasting detectable warning surface should be provided at the entrance and exit of the walk. The detectable warning surface shall extend the full width of the landing plate and have a depth of 600-900 mm, commencing 300 mm from the beginning of the landing plate.

i. Distinction between Comb and Floor Tread: There should be a visual and textural contrast between the tread comb and floor tread.

j. Slip Resistance: Landing plates and tread comb plates, located at each end of the moving walk, should be slip resistant if wet.

k. Illumination: Moving walks shall be evenly illuminated to at least 100 lux at the walkway floor surface.

l. Emergency Stop Button Configuration: A red emergency stop button should be located at the landings at each end of the moving walk. Emergency stop buttons should be visually identifiable, be mounted on the right-hand side of the landing, and should be facing the walk. The buttons should be covered with a transparent cover that can be easily lifted or pushed aside and comply with Section 3.3.10. When the cover is moved, an audible warning signal should be activated. The signal should be at least 80 dBA at the button location. The cover should be marked “EMERGENCY STOP,” “MOVE COVER” (or equivalent such as “LIFT COVER” or “SLIDE COVER”) and “PUSH BUTTON”. “EMERGENCY STOP” shall be in letters not less than 15 mm high. Other required wording shall be a minimum of 6 mm high. The cover should be self-resetting.

m. Emergency Stop Button Operation: The operation of an emergency stop button should completely shut down the moving walk in the direction of travel that the button serves. Once stopped, it should not be possible to restart the moving walk by releasing the emergency stop button alone.

n. Entry/Egress Caution Signs: A caution sign should be provided on approach to the start and end landings of the moving walk. Caution signs should be clearly visible in advance to embarking and disembarking users and should include the following



wording:

- a. “Caution”
- b. “Passengers only”
- c. “Hold Handrail”
- d. “Attend Children”
- e. “Avoid Sides”

The sign shall be standard for all moving walkways, and shall be identical in format, size, color, wording and pictorials. The sign should comply with the visual characteristics specified in Section 3.4.1.

o. Signs: Signs, in addition to entry and egress caution signs, that caution or warn users of the moving walk, should be clearly visible and unobstructed. Signs should not be located in an area that begins 3 meters from the end of the moving walk handrail extension to a point 900 mm measured from tread-comb toward the entry of the moving walk. Signs should be located so that they do not disrupt pedestrian flow or otherwise cause people boarding the moving walk to suddenly pause or stop.

3.2.8.4 Illustrations

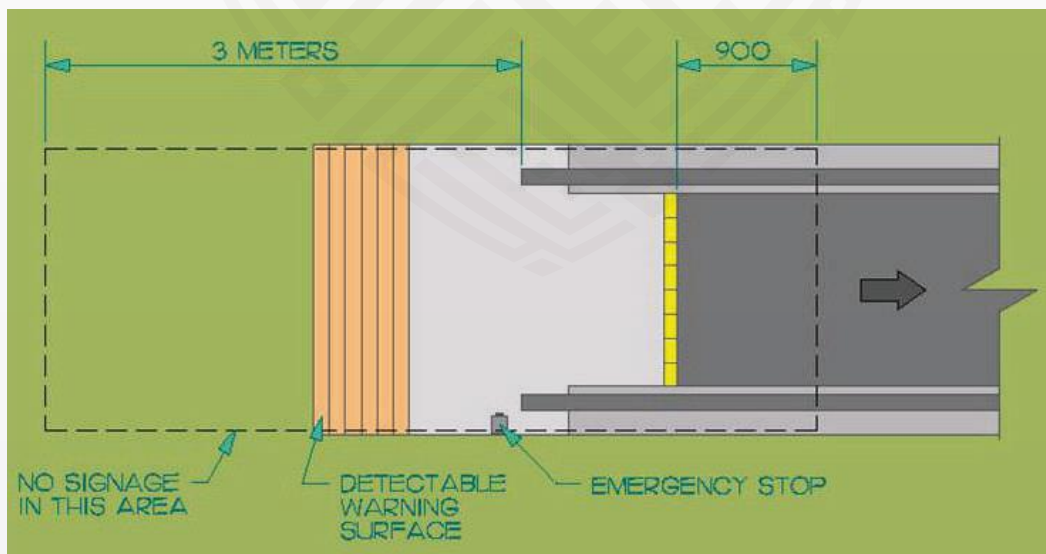

Figure 113: Moving Walk - Entry

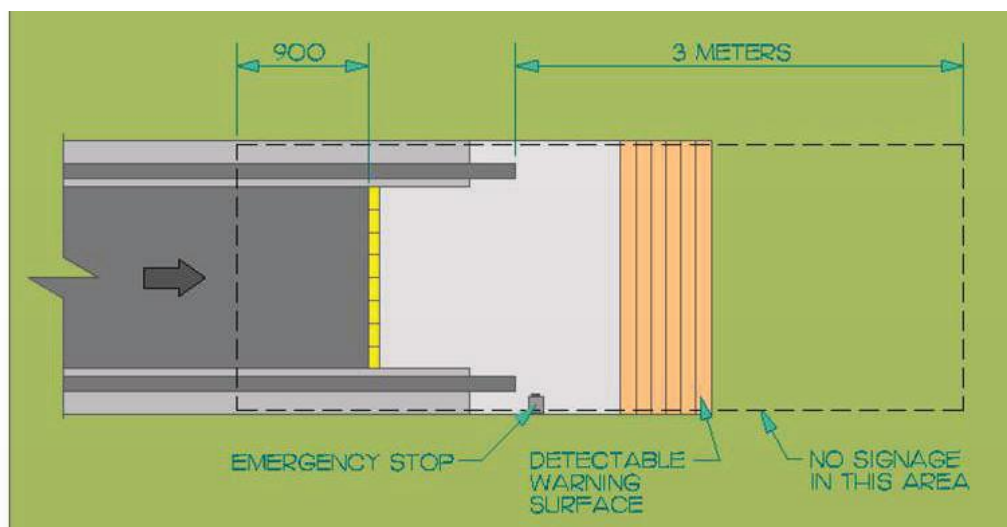

Figure 114: Moving Walk - Egress

3.2.8.5 Other Considerations

- 2.2 Anthropometric Data
- 3.2.25 Floor Surfaces
- 3.3.10 Controls and Operating Mechanisms
- 3.3.13 Handrails
- 3.4.1 Signage

- Appendix B Glare and Light Sources
- Appendix B Illumination
- Appendix B Materials and Finishes
- Appendix B Texture and Color



3.2.9 Doors

3.2.9.1 Design Considerations

Doorways should be designed to also accommodate the widely-varying dimensions of wheelchairs, mobility scooters, strollers and delivery carts. The opening of doors should not require the assistance from others. Consideration should be given to the installation of automatic door openers throughout a facility.

The height of thresholds should be minimised as much as possible to eliminate tripping hazards and prevent obstruction to device wheels.

Heavy doors should be avoided as they are challenging for people using wheelchairs and other mobility devices, people with strollers, children, seniors, or even someone carrying packages. Revolving doors are not accessible for people using wheelchairs or strollers, and the coordinated act of timely pushing may be beyond the capabilities of children or people with a cognitive disability. Whenever possible, entrances without doors are preferred.

Accessible doors should be one hand operable. When swinging doors are used, the direction of the door swing should be configured to maximise the usability of a space and limit hazards to other pedestrians. Sliding doors should be considered for ease of use and to reduce the space requirements for people using wheelchairs and other mobility devices.

Glazed doors should be marked with strips across the glass, mounted at eye level. The use of color-contrasting doorframes and door hardware will benefit people with visual impairments.

3.2.9.2 Application Guidelines

All doors used by the public or staff should comply with this section.

Exception: Where doors are accessed from one side only, such as at closets and other shallow storage spaces, the clear opening may be reduced to no less than 500 mm.

In a renovation situation where it is technically infeasible to make all doors accessible, at least one door that complies with this section should be provided into each accessible space.

All doors located at emergency exits, fire evacuation zones and areas of rescue assistance should comply with this section and Section 3.4.9.



If a single doorway incorporates multiple door leaves then at least one of the door leaves should comply with this section.

Power door operators should be installed at the following locations:

- building entrances, including both outer and inner vestibule doors (where provided)
- family toilet rooms
- at least one male and one female toilet facility per floor, that contains an accessible stall, when there is no family toilet room on the same floor
- change rooms that contain accessible toilet and shower facilities
- private accessible change rooms
- doorways connecting primary circulation routes, with the exception of doors that are held-open using electromagnetic devices.

Door mats and sunken/recessed mats should comply with this section.

Hardware installed on all doors, including those not located on accessible routes or entering accessible spaces, should comply this section.

3.2.9.3 Technical Guidelines

a. General: Accessible doors should be located on accessible routes that comply with Section 3.2.2. Where appropriate and permitted, rooms without doors are preferred.

b. Clear Opening: The minimum clear opening of doorways should be 900 mm, measured between the face of the door, or panic hardware if installed, and the opposing door stop when the door is opened to 90 degrees. In pre-existing conditions, off set or swing clear hinges can be installed to increase the clear opening of a door without enlarging the frame. In a renovation situation where it is technically infeasible to provide the required clearance, the minimum clear opening of doorways may be reduced to 850 mm. Doors that are not intended for user passage, such as at closets, may have a minimum clear opening of 500 mm.

c. Manoeuvring Space: Doors should provide wheelchair manoeuvring space on both sides of the door that complies with Figure 115. Wheelchair manoeuvring space should be unobstructed for the full height of the door. Wheelchair manoeuvring space is not required on the inactive side of a door, i.e. where access is intended to be from one side only such as at a closet. (*Figures 116-119*)

d. Thresholds: Thresholds should never be more than 13 mm higher than the surrounding surfaces, and should comply with Section 3.2.25. Flush thresholds are preferred. (*Figures 122 and 123*)



e. Door Hardware: All door hardware including handles, pulls, latches, and locks, should be operable by one hand and not require fine finger control, tight grasping, pinching, or twisting of the wrist to operate. Door hardware should be mounted between 900-1000 mm above the floor. Lever type handles should be used on latched doors where panic hardware is not required as the use of “U” shaped door levers will reduce the risk of snagging or injury from the exposed lever end. The use of “D” shaped handles on unlatched doors is acceptable. (Figure 124) Operating hardware on sliding doors should be extended above the surface of the door and should be usable from both sides when sliding doors are fully opened. Doors leading to hazardous areas, such as loading platforms and mechanical / electrical rooms should have a roughened or knurled texture on the handle as a tactile warning for people with visual impairments.

f. Opening Force: The maximum force required for opening a door by either pushing or pulling should be 38 N for exterior hinged doors, 22 N for interior hinged doors, and 22 N for sliding or folding doors.

g. Door Closers: Door closers (where installed) should be adjusted to comply with the maximum opening force in Clause (f). The sweep (closing) period of door closers should be adjusted so that, from an open position of 90 degrees, the door will take a minimum of 3 seconds to move to a partially closed position of approximately 12-degrees.

h. Kick plates: Kick plates at least 300 mm high should be provided on the push side of doors, to prevent damage from wheelchair footrests.

i. Power-Operated Hinged Doors: Power-operated hinged doors should take a minimum of 3 seconds to move from the closed position to the fully open position and should require a maximum force of 66 N to stop the door movement.

j. Entrance Vestibule Mats and Metal Gratings: Permanently fixed or installed mats and metal gratings at entrances, vestibules, or where provided, should be sunken or recessed so that the top surface of the mat or grating is level with the top of adjacent floor surfaces. Occasional or non-fixed mats, for example those installed and removed seasonally, should be level with the floor surface or have a gently bevelled edge that complies with Section 3.2.25.

k. Power Door Operators: Controls for power operators should be located to allow a person using a mobility device to stop immediately adjacent to the control. Power operator controls should be located at least 700 mm from any inside corner and if located on the hinge side of a door, should be located not less than 700 mm beyond the door swing. Controls should be clearly visible and include activation pads that measure a minimum of 150 mm in any direction. Activation pads should be marked with the International Symbol of Access for Persons with Disabilities. Two activation



pads should be provided on each side of the door and should be located at both 900 mm and at 225 mm above the floor, measured to their centreline. Alternatively, a vertical linear activation bar may be used, spanning the height of 225-900 mm above the floor. In areas of high pedestrian traffic, doors should be automatically activated. Alternatively, pressure-sensitive mats, overhead beams, or proximity scanners may be used to activate door operators. Proximity scanning should be used to detect pedestrian and wheelchair traffic within the door-opening arc, deactivating the opener until the area is clear.

l. Guards: Where hinged doors open across pedestrian travel routes, safety guards should be provided on either side of the door outward swing. Guards should extend a minimum of 300 mm perpendicular to the wall that the door is installed and should be cane detectable in compliance with Section 3.2.26. (*Figure 125*)

m. Revolving Doors or Turnstiles: Where revolving doors or turnstiles are installed, an alternate means of passage such as a gate or hinged door, should be provided adjacent to it in compliance with Section 3.1.13.

n. Frameless Glass Doors And Or Sidelights: Doors and sidelights that do not have a frame attached to all edges are not considered to be accessible, and should be avoided along accessible routes in compliance with 3.2.10.

o. Multiple-leaf Doorways: If doorways have more than one independently operated leaf, at least one active leaf should comply with this section. Where an accessible door is located within a bank of doors, it should be identified using the International Symbol of Access.

p. Two Doors in Series: The distance between two hinged or pivoted doors in series should be at least 1400 mm plus the width of any door swinging into the space. (*Figures 120 & 121*)

q. Security Viewers: Where security viewers are installed in a door, two should be provided with one at a height of 1100-1300 mm above the floor for seated & small stature people, and another at 1500 mm above the floor for standing people.

r. Color Contrast: Where doors are not equipped with a closing device, the vertical edge of the door should be color contrasted to the face of the door. Doors and door frames should incorporate pronounced color contrast, to differentiate them from the surrounding environment. Door handles and other operating mechanisms should incorporate pronounced color contrast, to differentiate them from the door itself. Power activation door pads should be color contrasted from their surroundings. (*Figure 126*)



s. Door Glazing / Vision Panels: Except where visual privacy is a legitimate concern (such as at washrooms and change rooms), doors should have a vision panel or adjacent sidelight installed. Vision panels and sidelights should have their lowest edge located a minimum of 750 mm above the floor, and be located a maximum of 250 mm from the latch side of the door. The glazing should not extend below 300 mm above the floor, to prevent damage from wheelchair footrests. Where a door incorporates glazing or is fully glazed, it should comply with Section 3.2.10.

Figure 115: Manoeuvring Space at Doors			
Floor Space Required (in mm)			
	Depth	Width	Space beside latch
Hinged door - Front approach (Figure 118)			
Pull side	1500	1600 (*1500)	600
Push side	1400	1250 (*1200)	300
Hinged door - Latch-side approach (Figure 117)			
Pull side	1400 (*1200)	1600 (*1500)	600
Push side	1400 (*1200)	1500	600
Hinged door - Hinge-side approach (Figure 116)			
Pull side	2100 (*1500)	2100 (*1500)	600
Push side	1400 (*1200)	1800	450
Sliding door (Figure 119)			
Pull side	1400	1200	50
Push side	1400 (*1200)	1550 (*1400)	600

Note: In renovation situations where it is technically infeasible to provide the required clearances at doors, the clearances may be reduced as indicated by the dimension noted above in the parentheses with an asterisk (*).



3.2.9.4 Illustrations

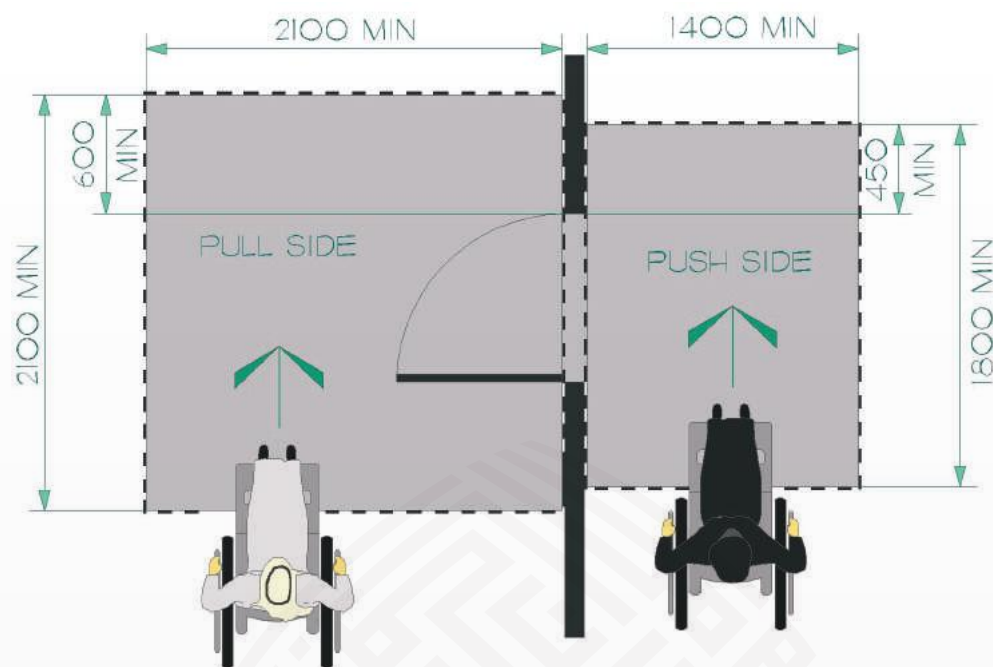

Figure 116: Hinge Side Approach at Hinged Doors

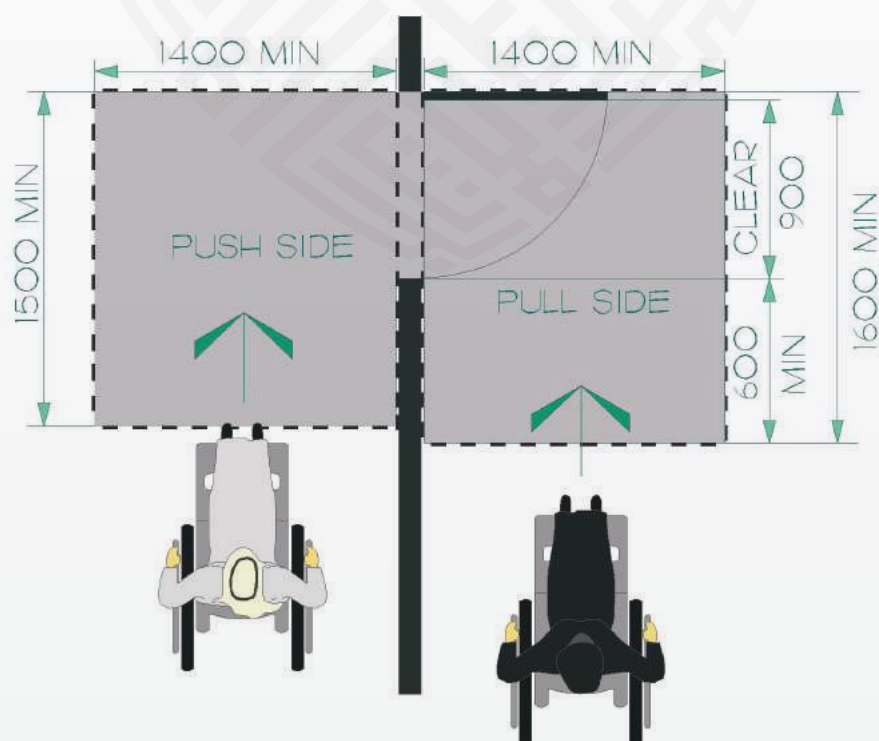

Figure 117: Latch Side Approach at Hinged Doors

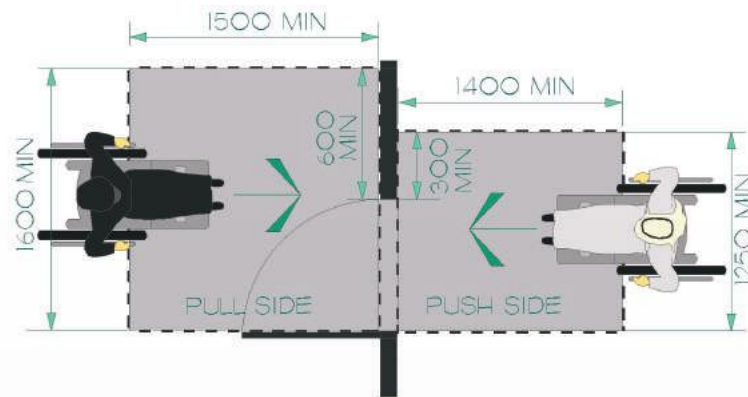

Figure 118: Front Approach at Hinged Doors

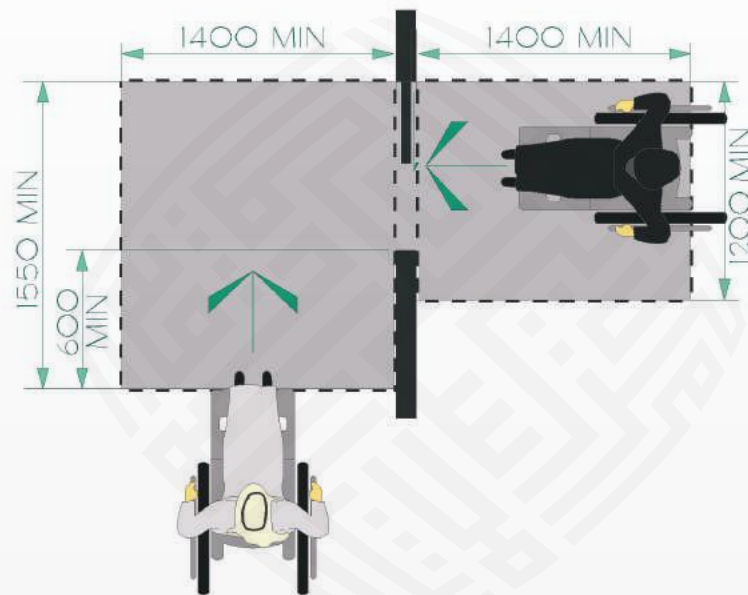

Figure 119: Front and Side Approach at Sliding Doors

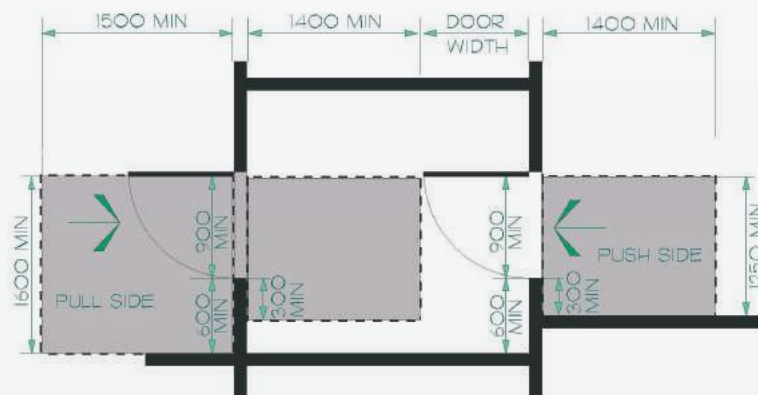

Figure 120: Manoeuvring Space at Doors in Series

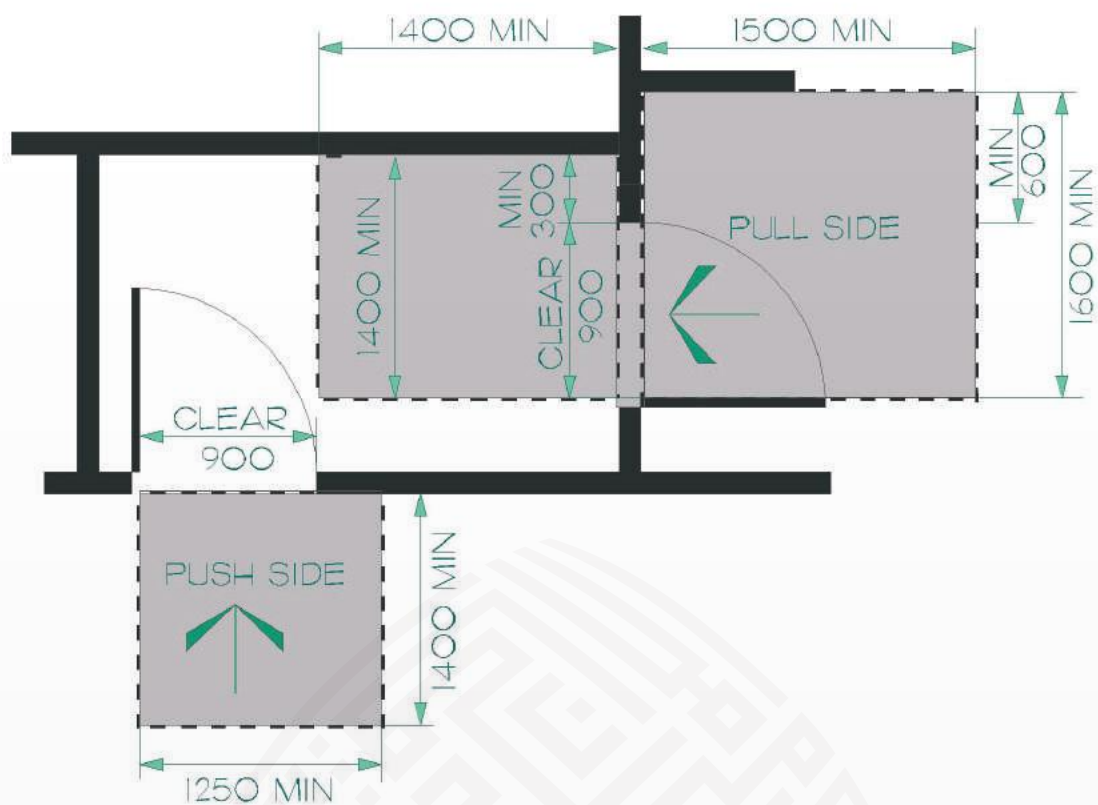

Figure 121: Manoeuvring Space at Doors in Series

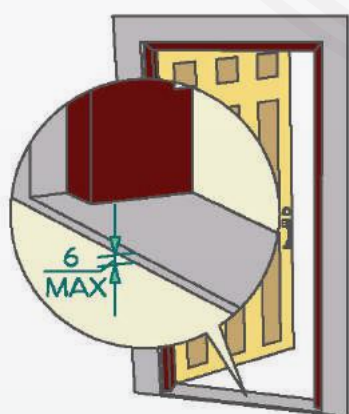

Figure 123: Door Threshold

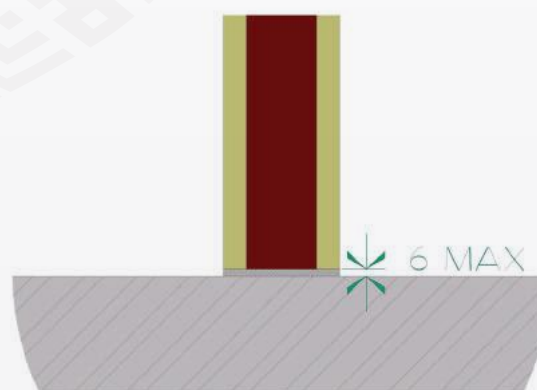

Figure 122: Door Threshold

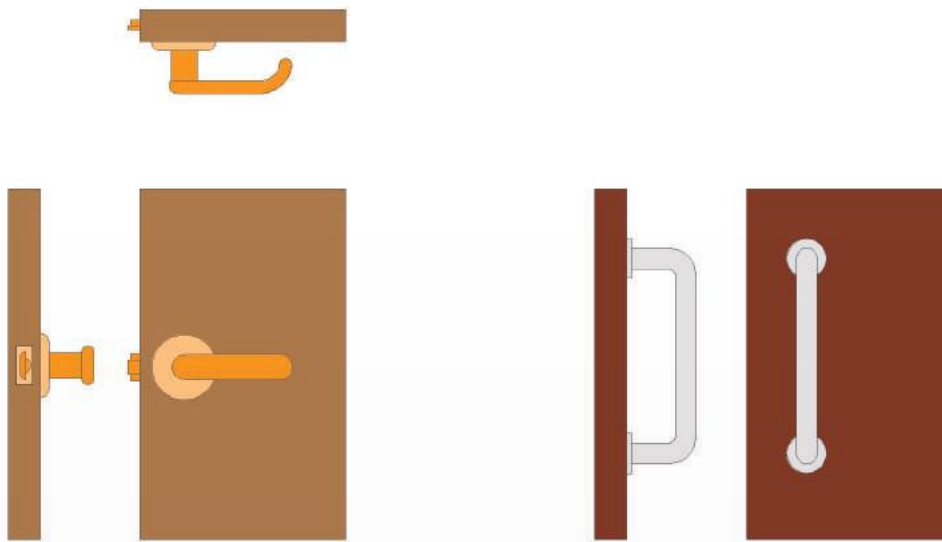

Figure 124: "U" shaped lever and "D" shaped handle.

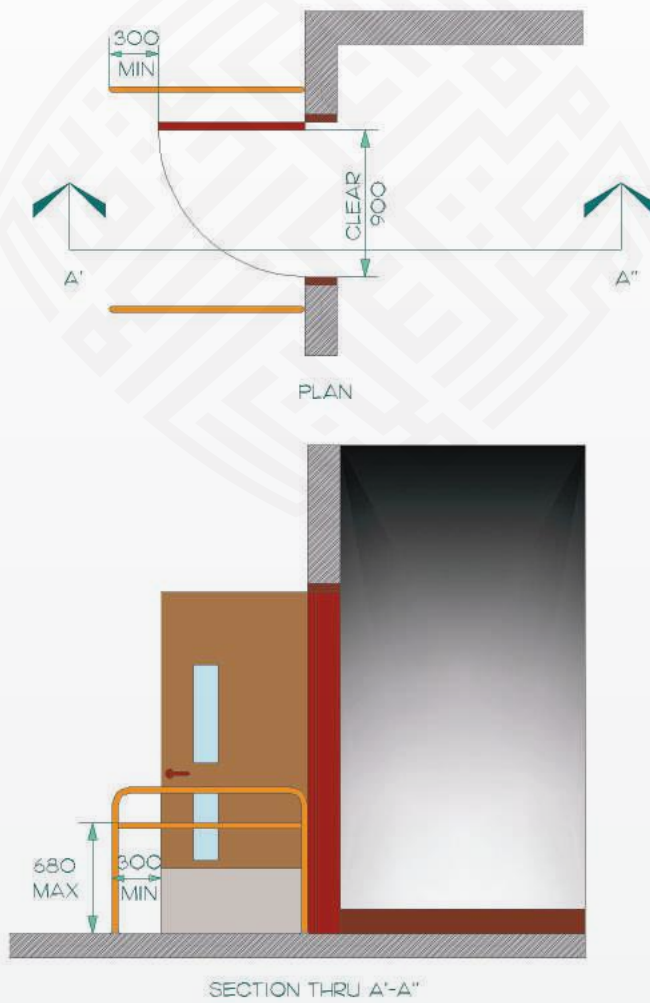

Figure 125: Detectable Guards

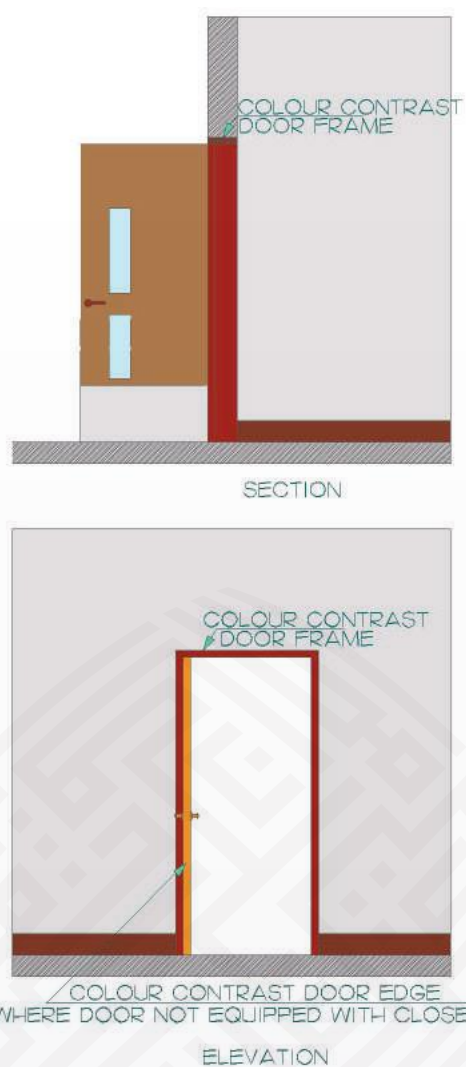

Figure 126: Color Contrast at Doors

3.2.9.5 Other Considerations

- 2.2 Anthropometric Data
- 3.2.10 Windows, Glazed Screens and Sidelights
- 3.2.27 Gates, Turnstiles and Openings
- 3.3.10 Controls and Operating Mechanisms
- 3.4.1 Signage
- 3.4.4 Information Systems
- 3.4.5 Card Access, Safety and Security Systems



3.2.10 Windows, Glazed Screens and Sidelights

3.2.10.1 Design Considerations

The use of glazing in doors, sidelights, and screens can be difficult to detect particularly for people with visual impairments, as well as individuals who are in a hurry or distracted. Window sills and operating mechanisms should be placed at an appropriate height to accommodate the lowered eye level and decreased reach range of people using wheelchairs or mobility devices. Window operating mechanisms should be designed to address limitations in hand strength and/or dexterity.

3.2.10.2 Application Guidelines

All windows, glazed screens, fully-glazed sidelights, fully-glazed doors, and vision panels in doors should comply with this section.

3.2.10.3 Technical Guidelines

a. Decals & Warning Stripes: All glazed doors and sidelights should be marked to draw attention to the presence of glazing. Markings should comprise of two horizontal rows of decals or continuous stripes that include contrasting colors and that have a minimum width of 50 mm. One row of markings should be located 1475-1525 mm above the floor, and the second at 1175-1225 mm, each measured to the centerline of the rows. Alternatively, a regular pattern of individual decals can be used to identify the glazing. Decals should measure a minimum of 50 mm across in any direction and may be of any shape, such as a logo, provided the solid portion of the decal incorporates color contrast to the background. Decals should be spaced at a maximum of 150 mm apart, measured from centre to centre. Markings having pronounced color contrast should also be provided where etched or patterned glass is used. (Figure 128)

b. Frameless Glass Doors and Vision Panels: Frameless glass doors and vision panels should be avoided wherever possible. Vertical safety tape should be applied to wrap the edges of any exposed glass panels.

c. Viewing Windows or Vision Panels: The sill height for viewing windows or vision panels should be a maximum of 750 mm above the floor. Horizontal transoms should not be positioned between 1000-1225 mm above the floor. (Figure 127)

d. Window Opening Hardware: Window opening hardware, where installed, should be mounted 400-1200 mm above the floor and comply with Section 3.3.10.



3.2.10.4 Illustrations

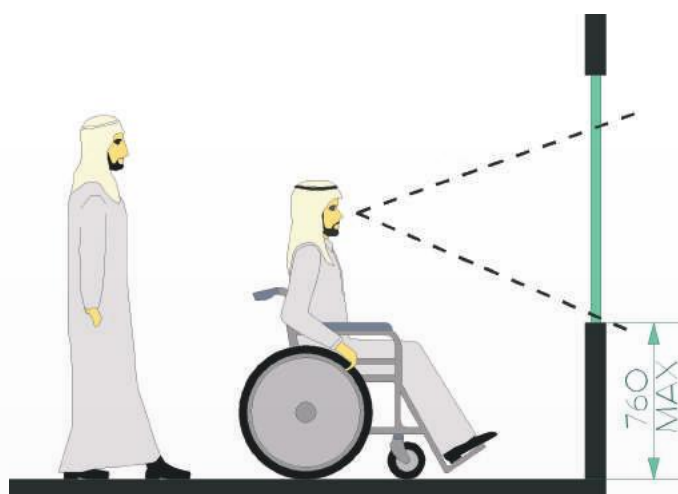

Figure 127: Window Sill Height

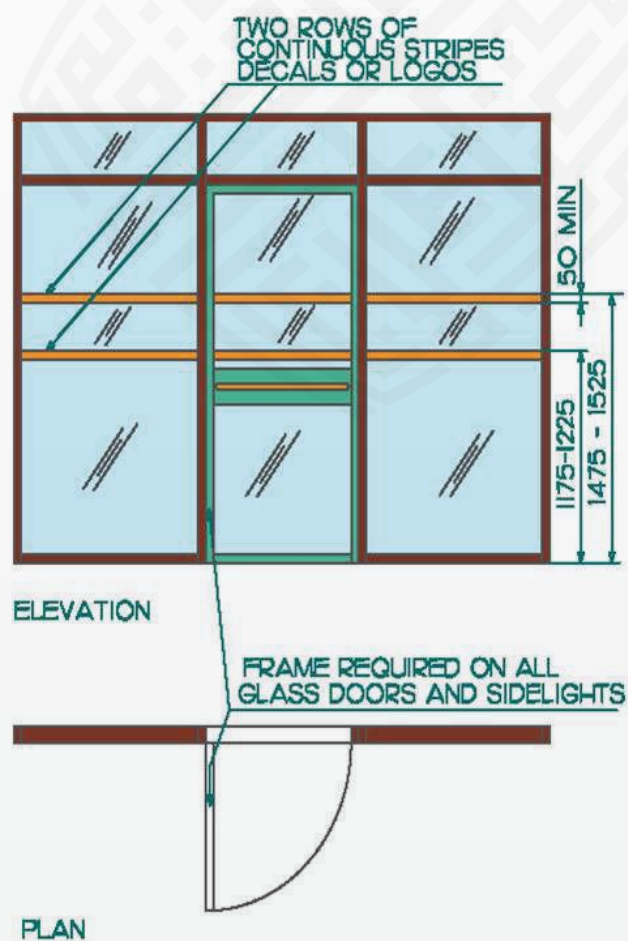

Figure 128: Fully Glazed Doors, Sidelights and Vision Panel Markings



3.2.10.5 Other Considerations

2.2 Anthropometric Data

3.3.10 Controls and Operating Mechanisms





3.2.11 Toilet Facilities

3.2.11.1 Design Considerations

Toilet facilities should be fully accessible to all people, regardless of mobility or functional profile.

People with disabilities may use toilet facilities independently or with assistance, and there should always be adequate space for mobility devices, assistive equipment and two or more people. A family toilet room will satisfy these demands, and provide parents or caregivers with ample room for multiple children, strollers and changing facilities.

Toilet facilities are pose safety hazards because of wet surfaces and the transfer of people between toilets and wheelchairs or mobility devices. When inward swinging doors are used, a fallen individual's position may prevent rescuers from opening the door. Safety features, such as non-slip materials and emergency call switches, are recommended to maximise the usability of the space and minimise risk to toilet facility users.

All facility users should be able to discern the location of toilet facilities quickly and easily. Signage that uses symbols or pictograms is particularly helpful for children and people have difficulty reading text, while those people with visual impairments will benefit from signs that utilise strong color contrasts. Ceiling hung or high wall-mounted directional signage should be highly visible. Color-contrasting door frames and door hardware will aid people with visual impairments, as well as, people who may be in a hurry or distracted.



Figure 129: Washbasin

Showing in-floor tactile detectable floor tiles to help people with visual disabilities to find the sink.



Figure 130: Accessible Signs



Figure 131: Accessible Signs

Showing in-floor tactile detectable floor tiles to help people with visual disabilities to find the sink.



3.2.11.2 Application Guidelines

All common-use public toilet facilities should comply with this section. In renovation situations where it is technically infeasible to make all common-use public facilities accessible, one individual toilet room per floor for each gender is permitted to be used instead.

Toilet facilities used by occupants within specific spaces, such as a toilet room located in a private office, are not expected to comply.

On floors in assembly type buildings containing common-use public toilets with four or more water closets and/or urinals, at least one accessible family toilet room should also be provided on the floor.

Where family toilet rooms are provided, they should be located on the same floor and within 45 m of the common-use public toilets.

Where bathing facilities occupy the same space as toilet facilities they should comply with this section, as well as Sections 3.2.19 and 3.2.20.

Where portable toilet facilities are provided in one or more locations, not less than 5% of units in each location should be accessible. Portable toilet facilities provided for use exclusively at construction sites are not required to comply with this section.

3.2.11.3 Technical Guidelines

a. Location: Accessible toilet facilities should be on located on an accessible route that complies with Section 3.2.2.

b. Signage: Accessible toilet facilities should be identified with signage that complies with Section 3.4.1. Where individual toilet rooms/facilities are not clearly visible from the location of the common-use public toilets, directional signage to the accessible toilet facilities should be provided, in compliance with Section 3.4.1.

c. Entrance Doors: Entrance doors to accessible toilet facilities should comply with Section 3.2.9. Entrance doors should not obstruct clear floor spaces required for use of fixtures. Where an entrance door swings inward, the minimum clearance between the inside face of the in-swinging door and the outside face of an adjacent toilet stall should be 1700 mm. Entries should be designed to provide visual privacy to the interior of the washroom. Entrance doors to accessible washroom facilities should have a power door operator installed in compliance with Section 3.2.9.



d. Clear Floor Space: Accessible toilet facilities should provide at least one clear floor space for people in wheeled mobility devices to complete a 180-degree turn. Required clear floor spaces are permitted to overlap each other. A clear floor space measuring at least 1600 mm wide and 1400 mm deep should be provided in front of entrances to accessible toilet stalls. A clear floor space measuring a minimum of 800 mm wide and 1400 mm deep should be provided in front of accessible washbasins where the required depth may extend under the washbasin a maximum of 500 mm. Where the accessible washbasin is located opposite the accessible toilet stall, a minimum clear space of 1500 mm should be provided between them (*Figure 132*).

e. Floor Surface: Floor surfaces should comply with Section 3.2.25.

f. Illumination: Toilet facilities and routes in toilet facilities should be illuminated at 200 lux.

g. Fixtures and Controls: The minimum distance between the outside face of an accessible stall and any wall-mounted fixture or control should be 1500 mm. Fixtures and controls within toilet and bathing rooms should be accessible in compliance with Section 3.3.10 and located on an accessible route that complies with Section 3.2.2.

3.2.11.4 Illustrations

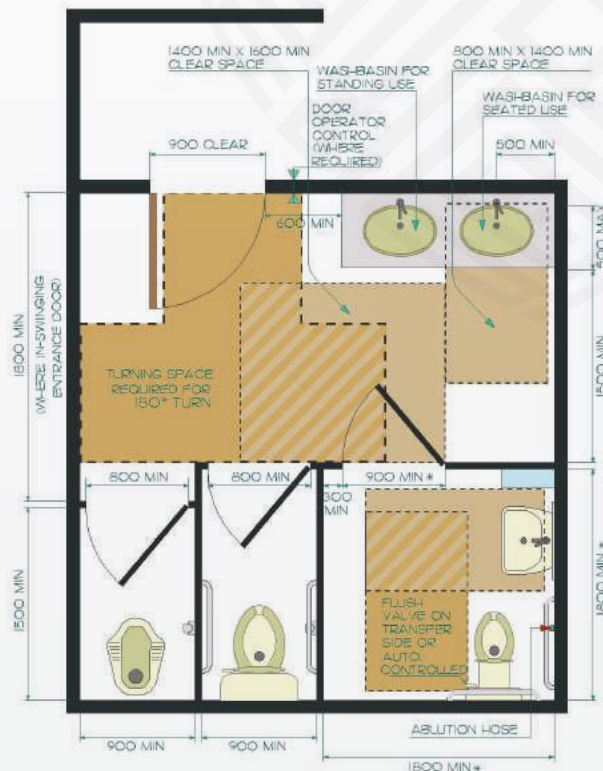

Note: In a renovation situation where it is technically infeasible to provide the required clearances, the dimensions marked with an asterisk (*) may be reduced. Refer to Section 3.2.2.

Figure 132: Washroom Dimensions



3.2.11.5 Other Considerations

- 2.2 Anthropometric Data
- 3.2.9 Doors
- 3.2.13 Family toilet rooms
- 3.2.14 Toilet Stalls
- 3.2.15 Water Closet (W.C.)
- 3.2.16 Washbasins
- 3.2.17 Urinals
- 3.2.18 Toilet Accessories
- 3.2.19 Bathtubs
- 3.2.20 Showers
- 3.2.21 Grab Bars
- 3.2.25 Floor Surfaces
- 3.2.26 Overhanging and Protruding Objects
- 3.3.10 Controls and Operating Mechanisms
- 3.4.1 Signage

- Appendix B Glare and Light Sources
- Appendix B Illumination
- Appendix B Materials and Finishes
- Appendix B Texture and Color



3.2.12 Ablution Spaces

3.2.12.1 Design Considerations

Ablution is a state that is prerequisite to praying. Ablution facilities should be available to everyone, including people with disabilities.

People who use wheelchairs or other mobility devices require an accessible washbasin to perform ablution routines. Washbasins will also be of benefit to people who have limited flexibility in their upper body. People who have limited strength and/or flexibility in their lower limbs will benefit from ablution facilities that incorporate seating.

Floor finish materials that remain slip-resistant when wet are a critical safety feature in ablution spaces.

Faucets and accessories, such as soap and towel dispensers, should be usable by everyone: mounting height and the configuration of operating mechanisms require careful consideration.

3.2.12.2 Application Guidelines

Ablution spaces should comply with this section.

A minimum of 5%, but never less than one, of ablution units should be designated and accessible to people with disabilities.

A minimum of 5%, but never less than one, of ablution units should be designated Limited Mobility Ablution Units.

3.2.12.3 Technical Guidelines

a. Doors: Doors into and within ablution spaces should comply with Section 3.2.9.

b. Circulation Routes: Ablution spaces and circulation routes within ablution spaces should comply with Section 3.2.2.

c. Floor Finish: Floor finishes within ablution spaces should be slip-resistant when wet, and should be anti-fungal and anti-bacterial. Grilles and gratings in ablution spaces and along circulation routes should comply with Section 3.2.25.

d. Built-In Elements: Built-in elements within ablution spaces, such as benches or seats, should be located on the same floor level as the circulation routes. Built-in elements should have no sharp edges and incorporate pronounced color-contrast to differentiate them from the surrounding environment.



e. Ablution Faucets: Ablution faucets may be hand operated or electronically controlled; Faucets activated manually should comply with Section 3.3.10. Faucets should incorporate pronounced color-contrasted to differentiate them from the surrounding environment.

f. Location of Accessible and Limited Mobility Ablution Units: Accessible and limited mobility ablution units should be located close to prayer rooms and on an accessible route complying with Section 3.2.2.

g. Configuration of Accessible Ablution Units: Accessible ablution units should have a washbasin complying with Section 3.2.16 and toilet accessories complying with Section 3.2.18. (Figures 133 and 134)

h. Configuration of Limited Mobility Ablution Units (LMAU): Limited mobility ablution units should include a seat that is between 400– 450 mm above the floor. LMAU's should be located so that one side is a maximum of 900 mm to an adjacent seat, wall or other obstacle. Ablution faucets should be located a maximum of 740 mm above the floor, with the spout located a maximum of 410 mm from the front edge of the seat. Toilet accessories should comply with Section 3.2.6. (Figures 135 and 136)

3.2.12.4 Illustrations

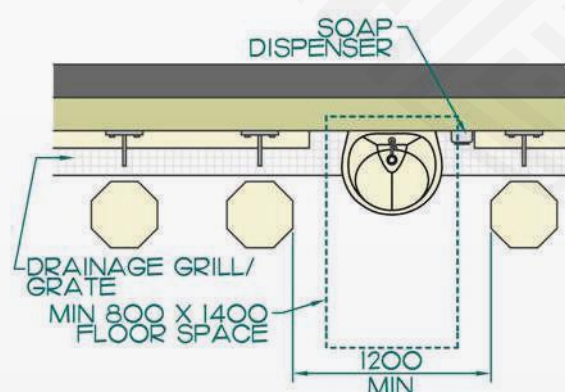

Figure 133: Accessible Ablution Unit

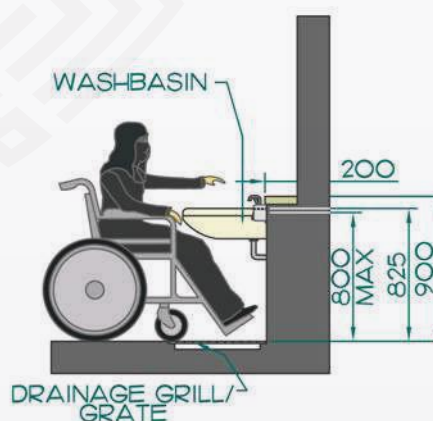

Figure 134: Accessible Ablution Unit

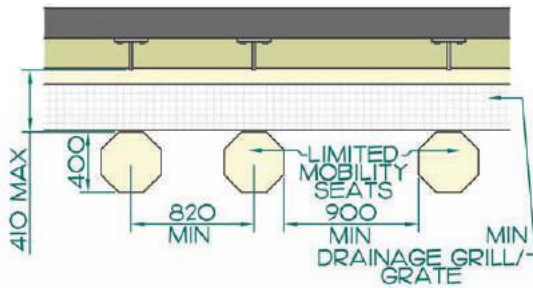

Figure 135: Limited Mobility Ablution Unit

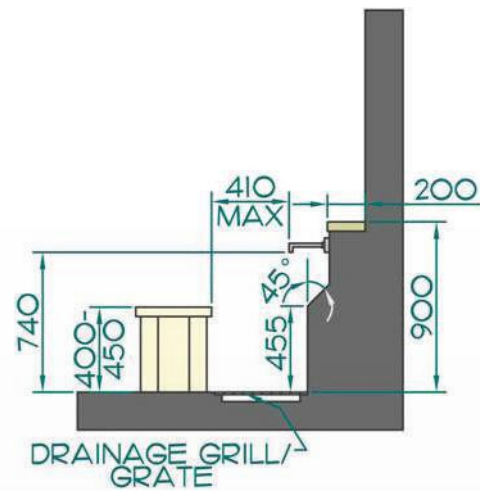

Figure 136: Limited Mobility Ablution Unit

3.2.12.5 Other Considerations

- 2.2 Anthropometric Data
- 3.2.2 Routes, Corridors and Access Aisles
- 3.2.9 Doors
- 3.2.16 Washbasins
- 3.2.18 Toilet Accessories
- 3.2.26 Overhanging and Protruding Objects
- 3.3.9 Storage, Shelving and Display Units
- 3.3.10 Controls and Operating Mechanisms
- 3.4.1 Signage
- 3.5.1 Mosques

- Appendix B Glare and Light Sources
- Appendix B Illumination
- Appendix B Materials and Finishes
- Appendix B Texture and Color



3.2.13 Family Toilet Rooms

3.2.13.1 Design Considerations

Providing family toilet rooms in public facilities should be considered for the special needs of people who use wheelchairs, as well as for families. Manoeuvring wheelchairs or mobility devices requires extra space in family toilet rooms, and the private nature of a separate toilet space can eliminate any complications arising from a mother entering a toilet facility with a child of an opposite gender.

All family toilet rooms should be fitted with safety features, such as an emergency call switch and a way of unlocking the door from the outside, to allow for access to the room should lone users have an accident or falls.

3.2.13.2 Application Guidelines

All family toilet rooms should comply with this section.

At least one family toilet room, in addition to accessible common-use public toilets, should be provided for each gender in

- in all public buildings; and
- on every floor level in assembly buildings where the floor incorporates common-use public toilets containing four or more toilet and/or urinal fixtures.

3.2.13.3 Technical Guidelines

a. General: Accessible family toilet rooms should be located on accessible routes that comply with Section 3.2.2. Accessible family toilet rooms should be located on the same floor level and within 45 meters of other common-use washrooms.

b. Signage: All family toilet rooms should be identified with signage that complies with Section 3.4.1. If family toilet rooms are not clearly visible from the common-use public toilet facilities, signage that complies with Section 3.4.1 directing users to the accessible family toilet room should be provided.

c. Entrance Door: Doors entering family toilet rooms should be accessible and comply with Section 3.2.9. Doors should include a latch operating and locking mechanism that is located between 900-1000 mm above the floor and that complies with Section 3.3.10. The latch operating and locking mechanism should also be capable of being released or opened from the exterior in the case of an emergency. (*Figures 137 and 139*)

d. Power Door Operator: Doors entering family toilet rooms should have power door operators installed that comply with Section 3.2.9.



e. “D”-Shaped Door Pull: Outward-swinging entrance doors should have a 140 mm long “D”-shaped door pull, located on the interior (push-side) of the door, with its centreline 200-300 mm from the hinged end of the door. The door pull should be located 900-1000 mm above the floor. *(Figure 139)*

f. Clear Floor Space: A clear space having a diameter not less than 2100 mm should be provided inside every accessible family toilet room. *(Figure 137)*

g. Toilet Fixture & Transfer Space: Accessible family toilet rooms should contain a water closet and accompanying transfer space that complies with Section 3.2.15. The use of wall hung toilets is desired. *(Figure 137)*

h. Washbasin: Accessible family toilet rooms should contain a washbasin conforming to Section 3.2.16. *(Figures 137, 138 and 139)*

j. Coat Hook: A family toilet room should be equipped with a collapsible coat hook that does not project more than 50 mm from the wall. Coat hooks should be installed on a side wall at a maximum height of 1200 mm above the floor.

k. Grab Bars: Family toilet rooms should have grab bars that comply with Section 3.2.21 and relevant parts of Section 3.2.15 as well as a fold-down grab bar should be provided on the transfer side of the toilet. Fold-down grab bars should measure at least 750 mm in length and be mounted between 420-440 mm away from the toilet, measured from the centre line of the toilet. The top member of a fold-down grab bar should be mounted at 800 mm above the floor, measured to its centreline. When in the raised position, the fold-down grab bar should not overlap the required clear transfer space beside the toilet fixture. *(Figures 137, 138 and 140)*

l. Accessories: Family toilet rooms should contain toilet accessories that comply with Section 3.2.18. *(Figures 137 to 140)*

m. Change Tables: Family toilet rooms should contain a baby change table that complies with Section 3.2.18. Baby change tables should be located on an accessible route within the room that complies with Section 3.2.2.

n. Emergency Call System: An emergency call strip-switch should be provided that complies with Section 3.2.15. *(Figures 137, 138 and 140)*

o. Color Contrast: There should be pronounced color contrast between door/wall/handles, wall/fixtures/controls, wall/grab bars, and wall/washroom accessories.



3.2.13.4 Illustrations

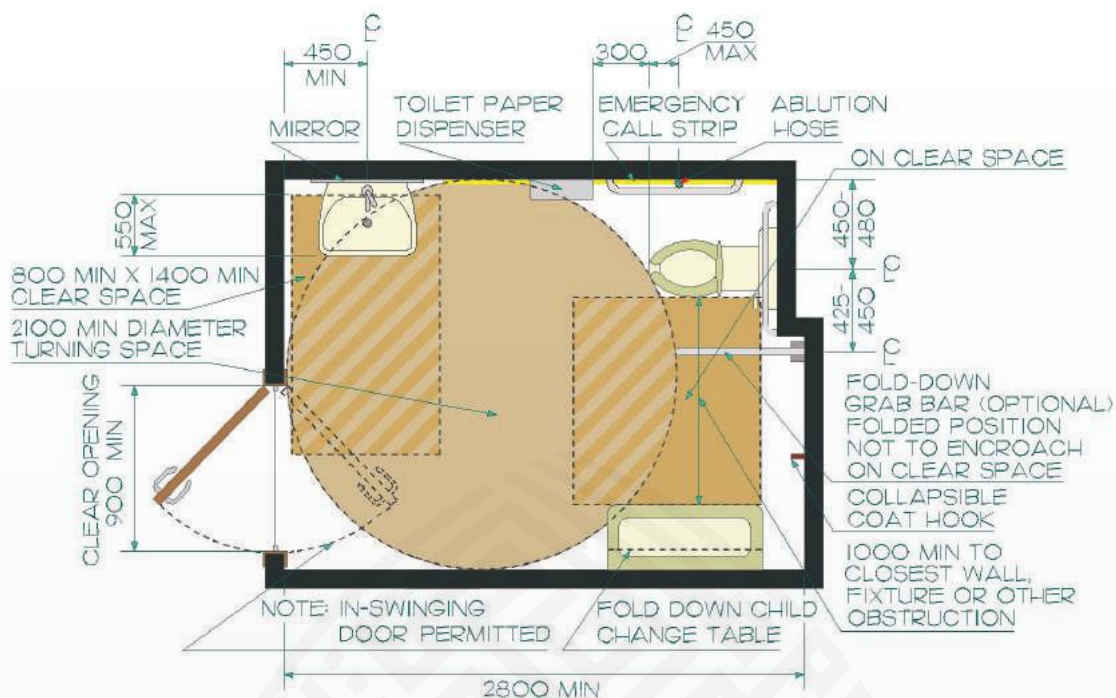

Figure 137: Family toilet room

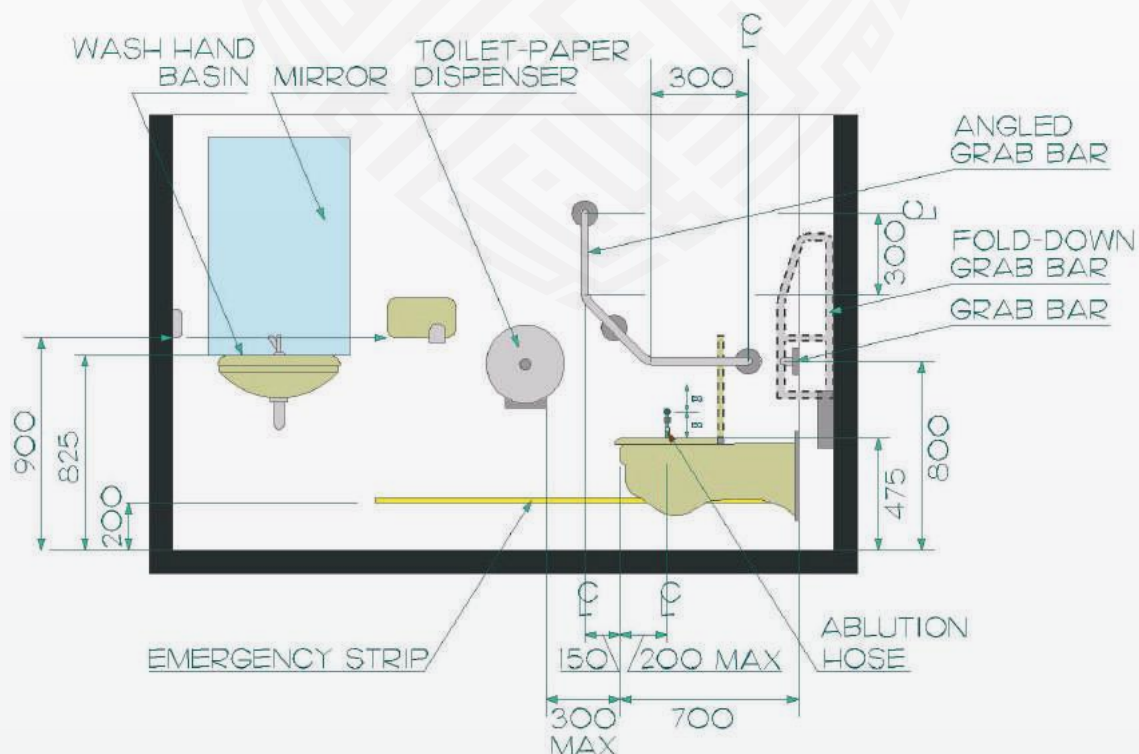

Figure 138: Family toilet room

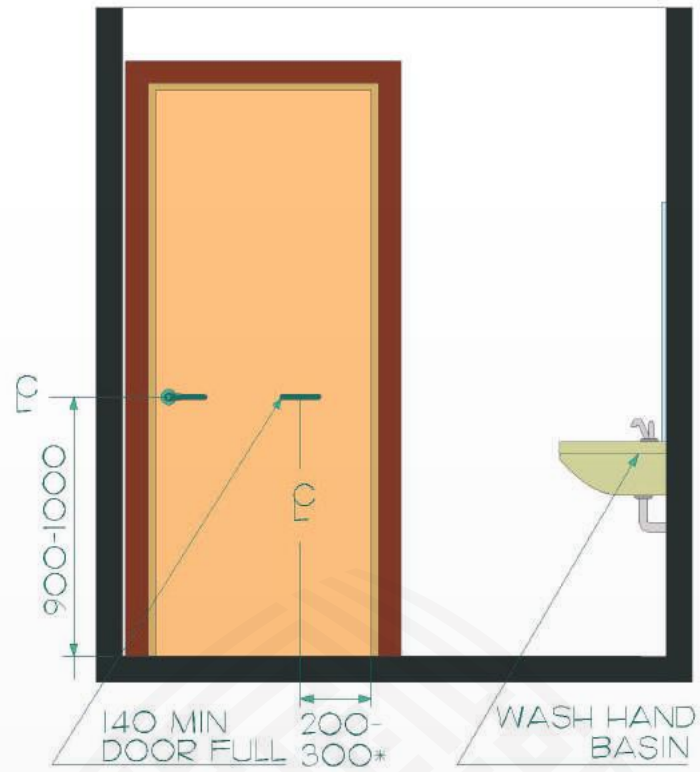

Figure 139: Family toilet room

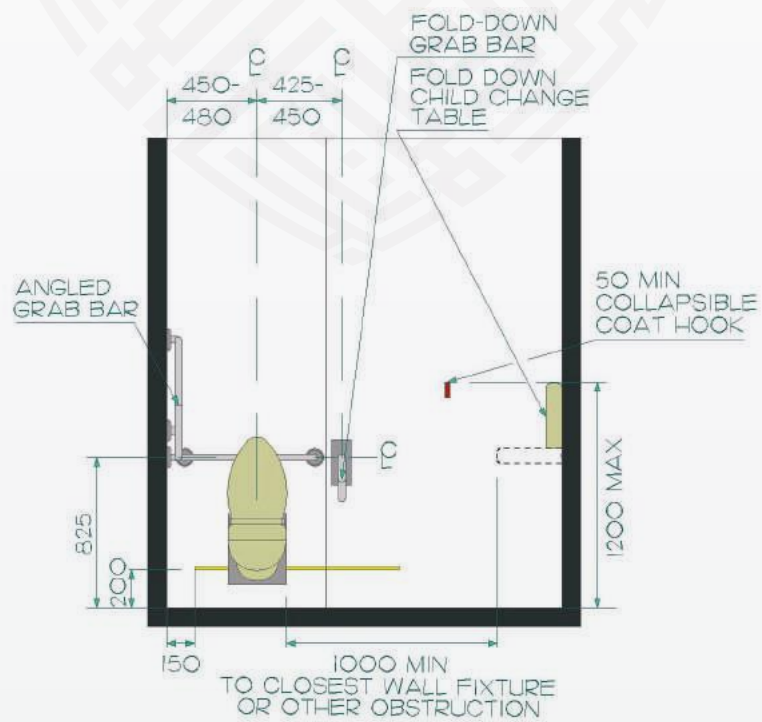

Figure 140: Family toilet room



3.2.13.5 Other Considerations

- 2.2 Anthropometric Data
- 3.2.9 Doors
- 3.2.14 Toilet Stalls
- 3.2.15 Water Closets
- 3.2.16 Washbasins
- 3.2.17 Urinals
- 3.2.21 Grab Bars
- 3.2.18 Toilet Accessories
- 3.2.25 Floor Surfaces
- 3.2.26 Overhanging and Protruding Objects
- 3.3.10 Controls and Operating Mechanisms
- 3.4.1 Signage
- 3.4.5 Card Access, Safety and Security Systems

Appendix B Glare and Light Sources

Appendix B Illumination

Appendix B Materials and Finishes

Appendix B Texture and Color

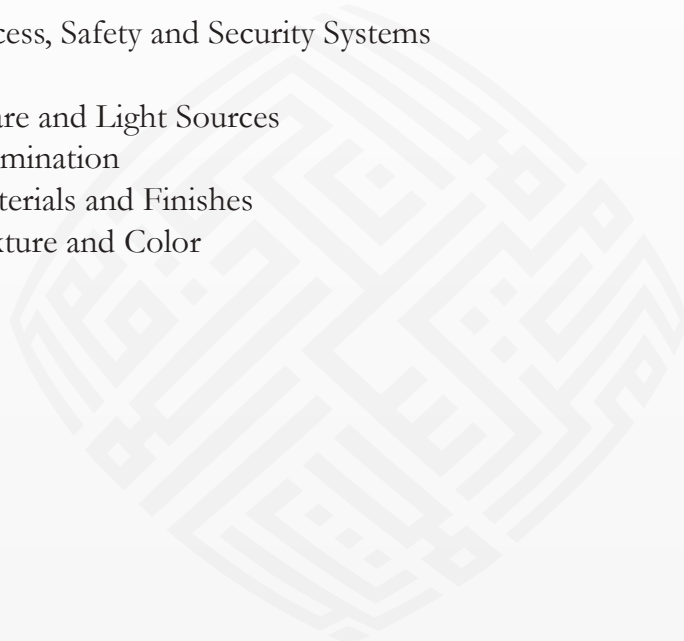



3.2.14

Toilet Stalls

3.2.14.1 Design Considerations

Accessible toilet stalls should be designed to accommodate the spatial needs of people with wheelchairs and mobility scooters. Stalls should be sized to ensure that there is sufficient space to place a wheelchair or mobility scooter in a position that allows a transfer onto and off of the western-style (seated) toilet fixture. Some people with disabilities will require assistance in toilet facilities and toilet stalls should be able to accommodate a second person.

An outward swinging door is an important safety feature that also saves space but it can make the door difficult to close from inside the stall. The installation of an additional inside handle part way along the door will make it easier for a person to close the door behind them.

The provision of limited mobility toilet stalls should be considered for people with mobility impairments who do not use wheelchairs or mobility scooters. Typically, these stalls are wider, feature grab bars and contain high western-style (seated) toilet fixtures. These stalls are particularly useful for seniors and people who are obese.

In addition, non-accessible toilet stalls should be available to people with disabilities that do not require the use of a wheelchair or mobility device. The installation of accessible hardware and a minimum width addresses the needs of people of a large stature or a parent with small children. A toddler security seat can also be incorporated within accessible toilet stalls.



Figure 141: Toddler Security Seat

Showing a toddler security seat within a family toilet room stall to allow the parent to use the facilities and keep the child safe.



3.2.14.2 Application Guidelines

Toilet stalls should comply with this section.

Where toilet stalls are provided in a facility, the minimum number of accessible toilet stalls should be as shown in Figure 142.

Where toilet stalls are provided in a facility, the minimum number of Limited Mobility toilet stalls should be as shown in Figure 142.

Figure 142: Number of Accessible and Limited Mobility Toilet Stalls

Total Number of Toilet Stalls Within the Washroom	Minimum Required Number of Accessible Toilet Stalls	Minimum Required Number of Limited Mobility Toilet Stalls
1 or 2	1	0
3 to 5	1	1
More than 5	2	1

3.2.14.3 Technical Guidelines

a. General: Accessible toilet stalls should be located on an accessible route that complies with Sections 3.2.2 and 3.2.11.

b. Toilet Stall Doors: The minimum clear width of an accessible toilet stall door should be a minimum of 900 mm, measured when the door is in the open position. In a renovation situation where it is technically infeasible to provide the required minimum clear width, the clear width of stall door opening may be reduced to 850 mm. Accessible toilet stall doors should swing outward from the stall, unless a minimum clear floor space measuring 800 mm wide by 1400 mm deep is provided within the stall. The required transfer space adjacent to the water closet should be aligned with toilet stall door. Stall doors should include gravity hinges that cause the door to return to the closed position if left open. The minimum clear width of a door opening in a limited mobility toilet stall should be at least 800 mm, measured when the door is in the open position. (Figures 132 and 143)

c. Stall Door Locks: All toilet stall doors, accessible and non-accessible, should have a locking mechanism that complies with Section 3.2.; for example a sliding bolt or lever. Toilet stall doors should be capable of being unlocked from the exterior in emergency situations.



d. Stall Dimensions: The minimum interior dimensions of an accessible toilet stall should be 1800x1800mm. In a renovation situation where it is technically infeasible to provide the minimum required interior dimensions, the width of the stall may be reduced to 1500mm. The minimum interior dimensions of a limited mobility toilet stall should be 900 mm wide by 1800 mm deep. All other toilet stalls, i.e. non-accessible stalls, should be no less than 900 mm wide. (*Figures 132 and 143*)

e. Toilet Accessories: Toilet accessories located in accessible and limited mobility stalls should comply with Section 3.2.18.

f. Transfer Space: Accessible toilet stalls should have a clear transfer space measuring a minimum of 900 mm wide, extending the full depth of the water closet, located on one side of the water closet. In a renovation situation, where it is technically infeasible to provide the minimum clear transfer space, the width may be reduced to 800 mm. Where more than one accessible toilet stall is provided within a toilet or bathing facility, water closets with transfer space located on opposing sides should be provided. Clear transfer spaces should be free of obstructions, such as toilet accessories except sanitary napkin disposal units which may be installed within the transfer space provided they are recessed or protrude a maximum of 100 mm into the transfer space. (*Figures 132 and 143*)

g. In-Stall Washbasin: Accessible stalls should contain an accessible washbasin. Washbasins should be located on the wall beside the toilet, with its closest edge 275 mm from the front edge of the toilet fixture. The depth of the washbasin should be a maximum of 400 mm. The top of the washbasin should be no higher than 825 mm above the floor and provide a minimum of 700 mm clear knee space beneath. Faucets should be in compliance with Section 3.2.16. Washbasin drains should be offset to maximize clearance under the sink. Water supply and drain pipes should be insulated. Mirrors and toilet accessories should comply with Section 3.2.18. (*Figures 143, 144 and 145*)

h. Pull Handles: Outward-swinging accessible stall doors should have a “D”-shaped pull located on the stall-side of the door. Pull handles should measure a minimum of 140 mm in length and should be located horizontally with their centreline 200-300 mm from the hinge edge of the door. Door pulls should be located 900-1000 mm above the floor. A second “D”-shaped pull handle should be provided on the exterior, push-side, with its centreline 200-300 mm from the latch side of the door. (*Figure 143 and 145*)

i. Door Hardware: Door hardware used on stall doors, such as handles, pulls, latches, and locks, should comply with Section 3.3.10 and be mounted at a height of 900-1000 mm above the floor.

j. Flush Controls: Toilet flush controls should be automatic, or be designed to comply with Section 3.3.10.



k. Grab Bars: Grab bars should comply with Section 3.2.21 and relevant parts of Section 3.2.15.

l. Coat Hook: Toilet stalls should be equipped with a collapsible coat hook mounted a maximum of 1200 mm above the floor, be located on a side wall, and should not project more than 50 mm from the wall surface.

m. Toilet Paper Dispenser: Accessible toilet stalls should be equipped with a toilet paper dispenser that complies with 3.2.15.

n. Emergency Call Switch: Accessible toilet stalls should be equipped with emergency call strip-switches in compliance with 3.2.15.

o. Color Contrast: Toilet stall partitions should incorporate pronounced color contrast, to differentiate them from the surrounding environment. Toilet stall doors should incorporate pronounced color contrast, to differentiate them from the toilet stall partitions. Door handles and locking mechanisms should incorporate pronounced color contrast, to differentiate them from the stall door. Grab bars should incorporate pronounced color contrast, to differentiate them from the surface they are mounted on.

3.2.14.4 Illustrations

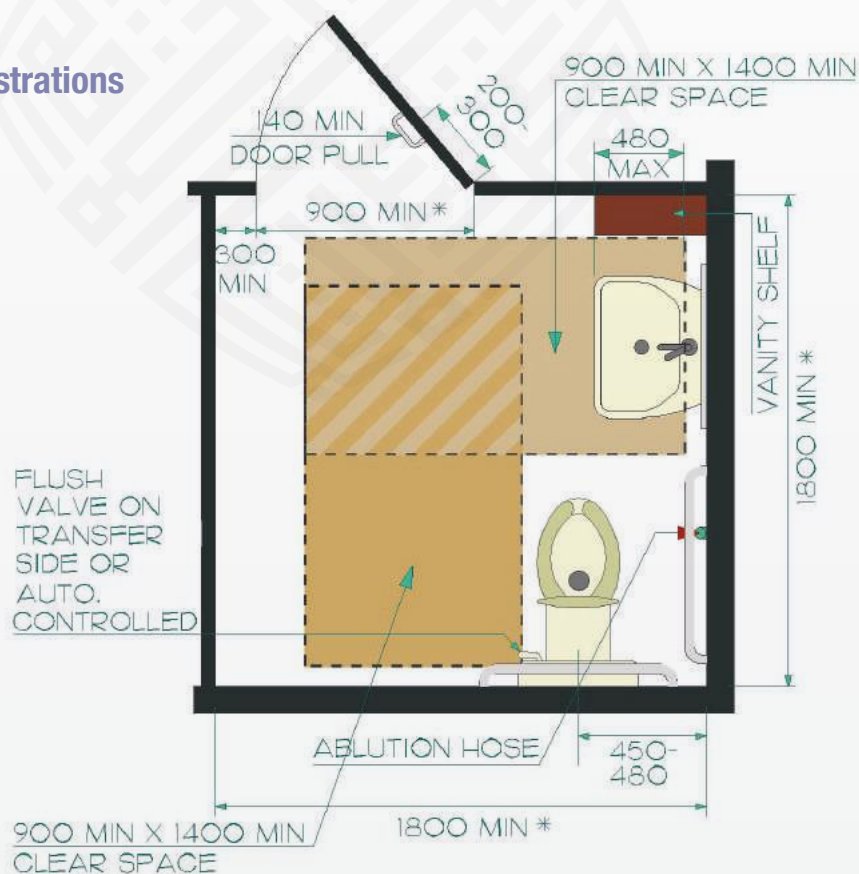

Figure 143: Accessible Toilet Stall – Plan

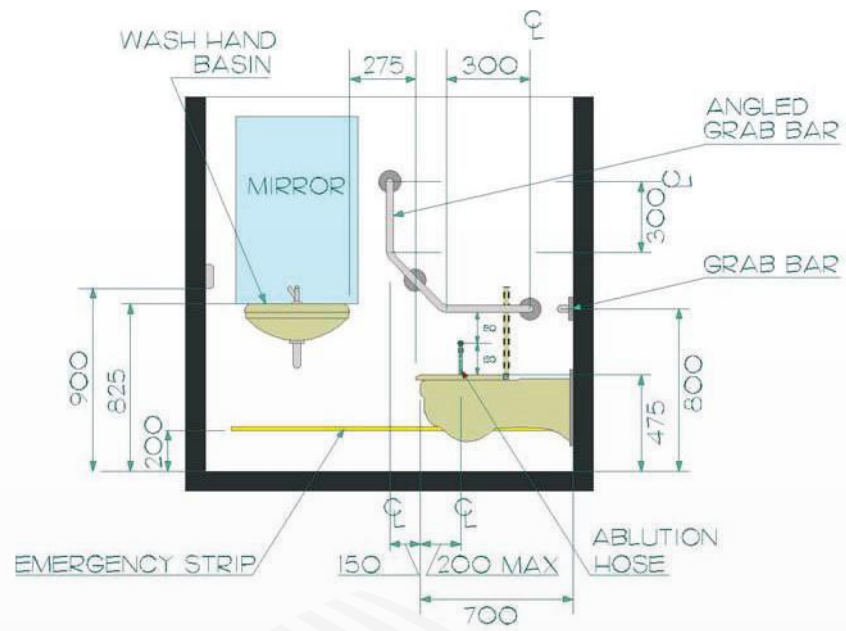

Figure 144: Accessible Toilet Stall

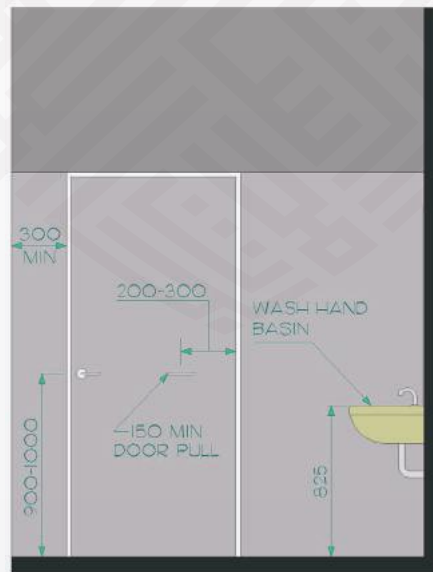

Figure 145: Accessible Toilet Stall

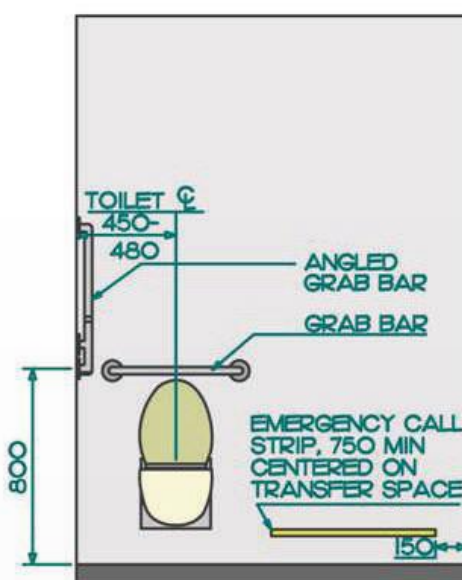

Figure 146: Accessible Toilet Stall

3.2.14.5 Other Considerations

- 2.2 Anthropometric Data
- 3.2.9 Doors
- 3.2.11 Toilet Facilities
- 3.2.18 Toilet Accessories
- 3.2.21 Grab Bars
- 3.2.26 Overhanging and Protruding Objects
- 3.3.10 Controls and Operating Mechanisms

Appendix B Illumination

Appendix B Texture and Color



3.2.15 Water Closets (WC)

3.2.15.1 Design Considerations

Western-style (seated) water closet (WC) fixtures are required within accessible and limited mobility toilet stalls as many people with disabilities are unable to use traditional (squat) toilets.

Toilet seats which are higher above the floor are easier to use for people with limited strength and/or flexibility.

Whenever possible, automatic flush controls should be installed. When flush mechanisms cannot be automated, lever style handles on the transfer side of the W.C. are recommended to accommodate limitations in reach, hand strength and dexterity.

Grab bars should always be installed alongside a WC to facilitate a safe transfer between the toilet and a mobility device and/or provide support for the acts of sitting and standing.

The use of 'high-tech' fully automated toilets should be given consideration as a way to enhance accessibility through automated washing and drying hygiene functions.

3.2.15.2 Application Guidelines

At least one accessible water closet should be located in each washroom facility, in every accessible stall, and in every family toilet room that complies with this section.

3.2.15.3 Technical Guidelines

a. Toilet Seat: Toilet seats should not be spring-activated. A back support should be provided where no seat lid or tank is included on a water closet. Where provided, water closet tank lids should be securely attached. Stronger toilet seat models that are well anchored should be provided to accommodate people who are obese.

b. Water Closet: Water Closets should have the top of the seat located 430-460 mm above the floor and measured to the centreline of the toilet, 450-480 mm from the closest side wall. Wall hung toilets are preferred. (*Figure 147*)

c. Transfer Space: A clear transfer space within accessible toilet stalls should be a minimum of 900 mm wide, extending the full depth of the water closet, and located on one side of the water closet. In a renovation situation, where it is technically infeasible to provide the minimum clear transfer space, the width may be reduced



to 800 mm. Clear transfer spaces should be free of obstructions, such as any toilet accessories except for sanitary napkin disposal units which may be installed within the transfer space provided they are recessed or protrude a maximum of 100 mm into the transfer space. (Figure 132 and 143)

d. Toilet Flush Controls: Flush controls may be manual or automatic. Where flush controls are automatic, it should include a gentle warning sound and light pre-flush to prevent confusion, alarm, or worry that flushing will not occur. Manual flush controls should be located on the transfer side of the water closet and be color contrasted with their surroundings.

e. Grab Bars in Accessible Toilet Stalls: Two grab bars should be located in each accessible toilet stall. One grab bar should be located behind the toilet, measuring at least 600 mm in length, centred across the toilet fixture, and mounted with its centreline 800 mm above the floor and 150 mm above any toilet element located underneath it. The second grab bar should be located on the side wall closest to the toilet fixture. The side grab bar should be of a “cranked” design, possessing a horizontal component 300 mm long, a 45 degree angled component 300 mm long and a vertical component 300 mm long. The side grab bar should be mounted with the centreline of its horizontal component 800 mm above the floor and the centreline of its vertical component 150 mm in front of the toilet bowl. Grab bars should also comply with Section 3.2.21. (Figure 147)

f. Grab Bars in Limited Mobility Toilet Stalls: A grab bar should be provided on each side wall of the limited mobility stall. Grab bars should be a minimum of 900 mm in length, located with their mid-point aligned with the front of the toilet fixture, and mounted with the centreline 800 mm above the floor. Grab bars should also comply with Section 3.2.21.

g. Toilet Paper Dispenser: Toilet paper dispensers should be mounted on the side wall closest to the water closet. Toilet paper dispensers should be located below the grab bar a minimum of 600 mm above the floor with the clearance between the toilet paper dispenser and grab bar a minimum of 60 mm. Toilet paper dispensers should be positioned in line with to a maximum of 300 mm in front of the toilet seat. (Figure 147)

h. Emergency Call Strip: A waterproof emergency call strip-switch that is a minimum length of 1200 mm should be provided on the side wall adjacent to the toilet fixture. The side emergency call strip should be located at 200 mm above the floor level, beginning 150 mm away from the rear corner of the wall. A second waterproof emergency call strip-switch that is a minimum length of 750 mm should be provided on the rear wall adjacent to the toilet fixture. The rear emergency call strip should be located at 200 mm above the floor and should be centred on the required transfer space beside the toilet fixture. Emergency call strips should activate a bell or other



signalling device that is monitored from a location within the facility. (Figure 144, 146 and 147)

i. Ablution-hose: An ablu-tion-hose should be provided at every toilet fixture, with a wall-attachment for the hose head. The hose-head attachment should be located to the left of the toilet (the right hand side of the seated user). Ablution hose heads should be positioned no more than 200 mm back from the front edge of the toilet fixture and vertically centred between the underside of the horizontal component of the side grab bar and the top of the toilet seat. Ablution hoses should have operating mechanism in compliance with Section 3.3.10. (Figure 147)

j. Child Size Toilet: In facilities where a many children will be present, one additional accessible stall should be provided with a lower child size toilet fixture.

k. Color Contrast: Toilet fixtures should incorporate pronounced color contrast, to differentiate them from the background environment. Grab bars should incorporate pronounced color contrast, to differentiate them from the surface they are mounted on. The emergency call strip-switch, flush controls, toilet paper dispensers and ablu-tions hoses, should incorporate pronounced color contrast, to differentiate them from the background environment.

3.2.15.4 Illustrations

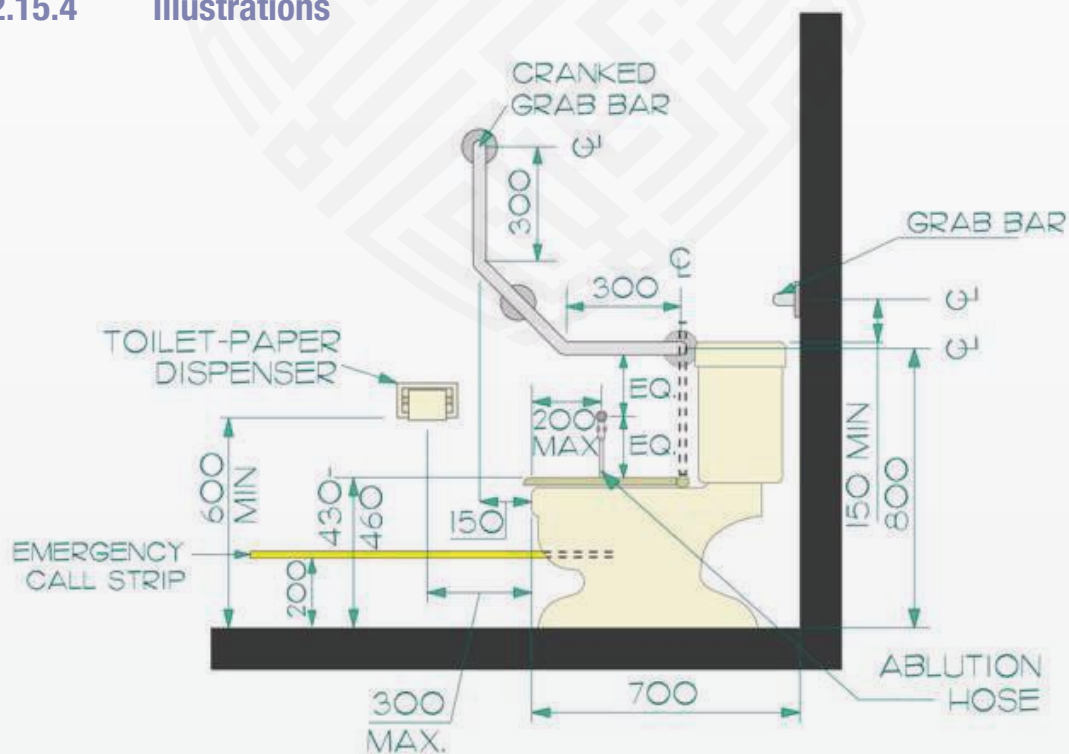

Figure 147: Accessible Toilet



3.2.15.5 Other Considerations

2.2 Anthropometric Data

3.2.14 Toilet Stall

3.2.21 Grab Bars

3.3.10 Controls and Operating Mechanisms

Appendix B Illumination

Appendix B Texture and Color





3.2.16 Washbasins

3.2.16.1 Design Considerations

Washbasins should be designed to facilitate the broad range of individuals who will use them. Operating mechanisms should be selected and installed for ease of use. Remote-eye sensor technology provides unparalleled accessibility and convenience, even if it is initial confusing to some users. For people who have limited hand strength or dexterity, lever-style handles are desirable alternatives.

A lowered counter will provide equitable access for children, people short in stature and those individuals using wheelchairs or mobility devices. When more than one washbasin is provided, a range of counter heights is an optimal solution to address the needs of people with varying statures. There should be sufficient space under the counter with the washbasin intended for use by people in wheelchairs to comfortably accommodate the combined depth of an individual’s knees and wheelchair. Hot water and drain pipes should be insulated to protect the legs of people using wheelchairs, especially when a person’s disability impairs the sensation of heat.

The combination of swallow sinks and strong water pressures can result in unacceptable splashing at washbasin areas, leading to personal discomfort, wet counter tops, and slipping hazards.

3.2.16.2 Application Guidelines

All washbasins should comply with this section.

The type and minimum number of washbasins to be provided should comply with *Figure 148*.

Figure 148: Type of washbasins to be provided

Total number of washbasins provided within the washroom	Minimum required number of accessible washbasins	Minimum required Number of washbasins for standing users
1	1	0
2	1	1
3	1	2
4 or more	at least 50% of the total provided	



3.2.16.3 Technical Guidelines

a. General: Washbasins should be located on an accessible route that complies with Section 3.2.2.

b. Mounting Location: The top of accessible washbasins should be located a maximum of 850 mm above the floor. Washbasins for standing users should have the top located 900-950 mm above the floor. Washbasins should be located so that the minimum distance between the centre line of the fixture and the side wall is 450 mm. (*Figure 149*)

c. Knee Space: Accessible washbasins and vanity counters should have a knee space beneath in compliance with Section 2.2. Drains from accessible washbasins should be offset to maximize clearance under the sink. (*Figure 149*)

d. Clear floor space: There should be a minimum 800 mm wide and 1400 mm deep clear floor space in front of accessible washbasins; the clear space may extend a maximum of 550 mm under the washbasin or counter, measured from the leading edge. (*Figure 132*)

e. Faucets: Faucets should be electronically controlled or have a single long lever-style handle that is operable with a clenched fist and complies with Section 3.3.10. Faucets at accessible washbasins should not self-close, i.e. stop water flow, unless manually activated to do so. The centre line of a faucet measured to the edge of the basin, or where the basin is mounted in a vanity, to the front edge of the vanity, should not exceed 500 mm. The hot and cold water directions should be intuitive, consistent, and marked with color contrasted and raised letters for easy identification.

f. Dispensers: Dispensers at accessible washbasins, such as soap and towel dispensers, should be located to avoid reaching over the washbasin. Dispensers should be located so that the dispensing height is a maximum of 1200 mm above the floor. Dispensers should be operable with one hand, be color-contrasted from the surrounding environment; and comply with Section 3.3.10.

g. Water Temperature: Hot water and drain pipes beneath accessible washbasins should be insulated. Hot water temperature should be limited to a maximum of 45 degrees Celsius.

h. Shelves: Shelves or other projections above washbasins should be installed at a height and depth that eliminates hazards to people with visual impairments and comply with Section 3.2.26.



i. Mirrors: Where mirrors are provided at washbasins or vanity units, they should comply with Section 3.2.18 and be located with their bottom edge a maximum of 1000 mm above the floor. In renovation situations where a mirror's bottom edge cannot be located lower than 1000 mm, a tilted mirror may be used. (Figure 149)

j. Color Contrast: There should be color contrast between wall/washbasin/faucet and wall/soap-dispenser/towel-dispenser/towel-disposal/hand dryer units.

3.2.16.4 Illustrations

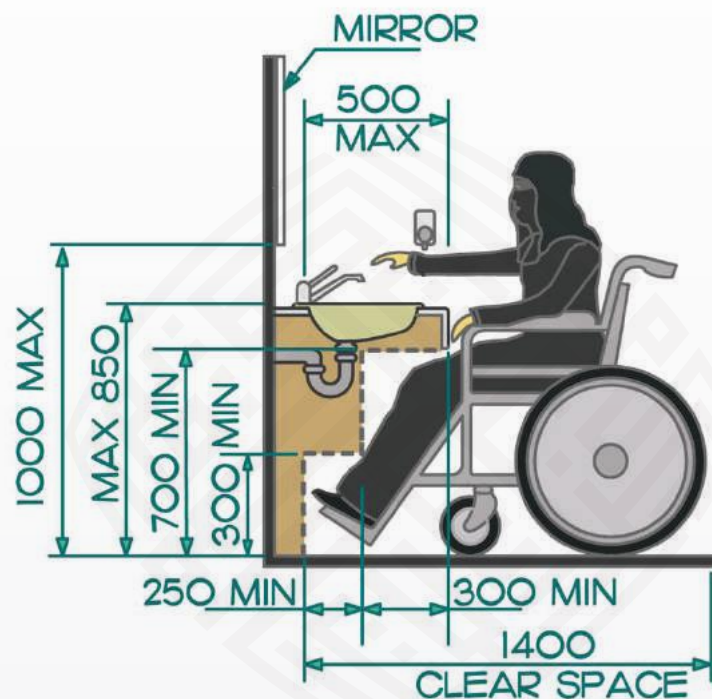

Figure 149: Accessible Washbasin Configuration

3.2.16.5 Other Considerations

2.2 Anthropometric Data

3.3.10 Controls and Operating Mechanisms

Appendix B Illumination

Appendix B Texture and Color



3.2.17

Urinals

3.2.17.1 Design Considerations

The space in front of urinals should be adequately sized to accommodate the operation of a mobility device. Grab bars should be provided on both sides of the urinal to assist a person rising from a seated position and/or holding themselves steady. For children, people of short stature or those draining personal care devices, a floor-mounted urinal will provide easy and equitable access. It is preferable for flush mechanisms to be automatic, but when this is impractical, lever-style flush controls should be chosen to address limitations in reach, hand strength or dexterity.

The urinal, the wall and the floor should be differentiated with contrasting colors and the exact position of the urinal should be indicated with a tactile and color-contrasting marker for people with visual impairments.



Figure 150: Urinal

Showing a urinal with side and top grab bars, an emergency call button and detectable floor tactile tiles in front of the secondary urinal with hands-free flushing.

3.2.17.2 Application Guidelines

Where urinals are provided, at least one urinal should comply with this section.



3.2.17.3 Technical Guidelines

a. Urinal Types: Accessible urinals should be wall-mounted and include an elongated rim that is a maximum of 425 mm above the floor. Alternatively, they may be a stall-type urinal, with the rim at the finished floor level. Urinals should be a minimum of 350 mm deep, measured from the outer face of the urinal rim to the back of the fixture.

b. Clear Floor Space: A minimum clear floor space measuring 800 mm wide by 1400 mm deep should be provided directly in front of the urinal to allow for a forward approach by a wheeled mobility device.

c. Urinal Stall Dimensions: Where provided accessible urinal stalls should have internal dimensions a minimum of 1800x1800 mm. In a renovation situation, where providing the required internal dimension is technically infeasible, the internal dimensions may be reduced to 1500x1500 mm.

d. Urinal Stall Doors: Accessible urinal stall doors should be provided with a minimum clear opening width of 900 mm when the door is in the open position. In a renovation situation, where it is technically infeasible to provide the required clear opening, the clear opening may be reduced to 850 mm. Doors should swing outward, unless clear floor space is provided within the stall for a wheelchair, that does not overlap with the door swing. Stall doors should be equipped with gravity hinges that cause the door to return to the closed position when opened.

e. Urinal Stall Door Locks: Door locks should be provided on urinal stall doors and should be capable of being locked from the inside by a mechanism that complies with Section 3.3.10, for example a sliding bolt or lever. Urinal stall doors should be capable of being unlocked from the exterior in the case of an emergency.

f. Urinal Flush Controls: Urinal controls may be manually or automatically activated and should comply with Section 3.3.10. Manual flush controls should be mounted at maximum height of 1100 mm above the floor.

g. Grab Bars: Grab bars should be provided on both sides of the urinal. Grab bars should be a minimum of 600 mm in length and comply with Section 3.2.21. Grab bars should be mounted no more than 375 mm away from the urinal, measured from the centre line of the urinal, and the lowest surface of a grab bar should be located between 600-650 mm above the floor. (Figure 152)

h. Ablution hose: An abluion hose should be provided at an accessible urinal, with a wall-attachment for the hose head. The hose head should be located on the right-hand-side of the urinal, mounted 900-1100 mm above the floor. Ablution hoses should have operating mechanisms that comply with Section 3.3.10.



i. Vertical Markers: A vertical marker should be provided above urinals that projects from the surrounding surface a minimum of 3 mm and is color contrasted to the surrounding surfaces. Vertical markers should be located so that they are centred across the urinal with the bottom edge located a minimum of 150 mm above the top of the urinal. Vertical markers should be no less than 50 mm wide and extend to a minimum height of 1300 mm above the floor.

j. Color Contrast: There should be pronounced color contrast between wall/urinal, wall/flush controls and wall/grab bars.

3.2.17.4 Illustrations

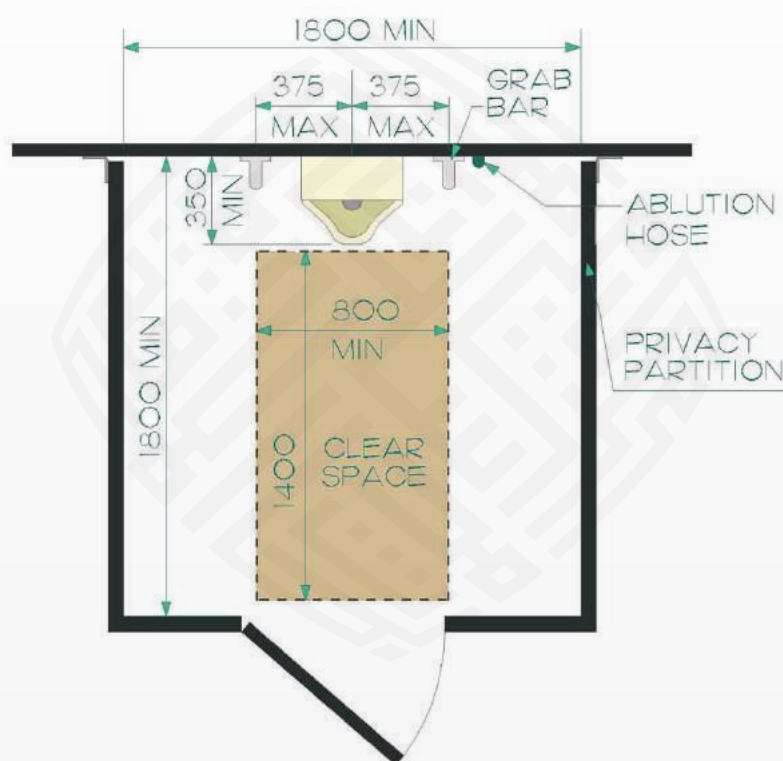

Figure 151: Urinal Stall

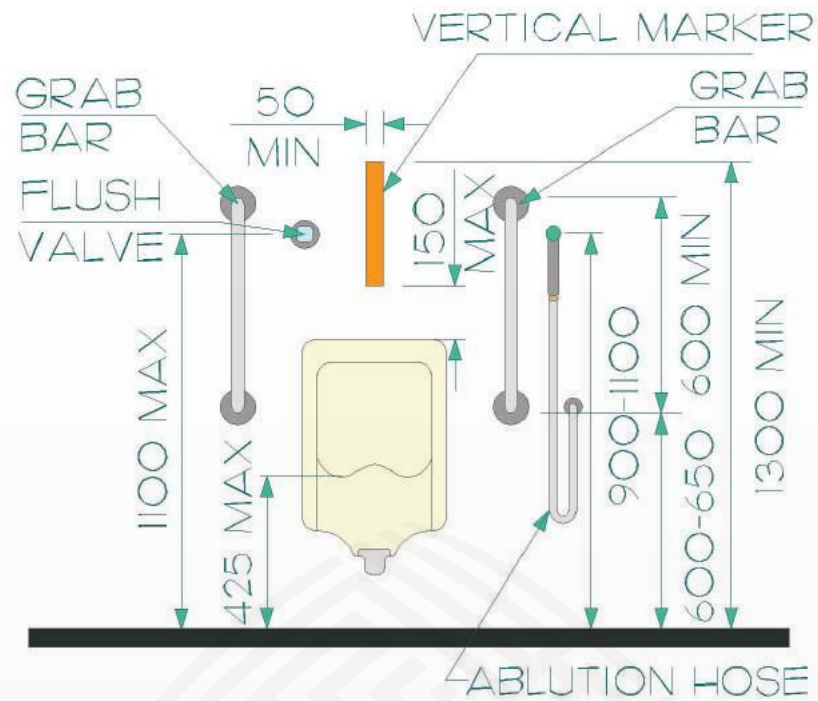

Figure 152: Urinal Elevation

3.2.17.5 Other Considerations

- 2.2 Anthropometric Data
- 3.3.10 Controls and Operating Mechanisms

- Appendix B Illumination
- Appendix B Texture and Color



3.2.18 Toilet Accessories

3.2.18.1 Design Considerations

All toilet accessories should be designed to accommodate the full range of potential users. The operating mechanisms of accessories should account for limitations in hand strength and dexterity, while the placement of accessories should address the limited reach range of people in wheelchairs or mobility devices, children, and people of short stature. Accessories that require two hands to operate are problematic to people who experience difficulties with reach or balance. Accessories in a toilet facility should be laid out logically, conveniently, and consistently throughout a facility in order that a person with a visual impairment may anticipate and easily find the location of accessories such as hand soap dispensers, paper towel dispensers or hand dryers, garbage cans, etc.

3.2.18.2 Application Guidelines

All toilet accessories provided within accessible toilet or bathing facilities should comply with this section.

In a renovation situation, where it is technically infeasible to have all toilet accessories comply with this section, at least one of each type of washroom accessory should comply with this section.

3.2.18.3 Technical Guidelines

a. Operable Mechanisms: Toilet accessories should have operable portions and controls mounted 900-1200 mm above the floor. The operable controls and mechanisms should comply with Section 3.4.2. (Figure 153)

b. Clear Floor Space: A clear floor space measuring a minimum of 800 mm wide by 1400 mm deep should be provided in front of each accessory provided. Clear floor spaces of adjacent toilet accessories are permitted to overlap.

c. Mirrors: When mirrors are provided, at least one mirror should be inclined and vertically adjustable by a person using a wheelchair, or mounted with the bottom edge a maximum of 1000 mm above the floor.

d. Soap Dispensers: At least one soap dispenser should be mounted near the front edge of a washbasin that has reach requirements in compliance with Section 2.2.

e. Paper Towel Dispensers / Hot Air Hand Dryers: At least two paper towel dispensers and/or hot air hand dryers should be provided in accessible facilities, mounted at different heights above the floor. One unit should be mounted at a maximum of



1200 mm above the floor, measured to its centreline, and the second unit should be mounted at a maximum height of 1500 mm above the floor, measured to its centreline. Paper towel dispensers and/or hot air hand dryers may be manually or automatically activated; although automatic is the preferred method.

f. Baby Change Tables: Where baby change tables are provided, they should be of a fold down type with the change surface a maximum of 850 mm above the floor. No operable mechanisms of the baby change tables should be located higher than 1200 mm above the floor. The change table should be designed to carry a maximum load of 1.33 kN (300 lbs). A shelf for a diaper bag should be provided and located to within reach requirements that comply with Section 2.2.

g. Garbage Containers: Garbage containers should be located in proximity to washbasins and located so that the container, or use of it, does not block access to or use of other washroom facilities and accessories. Garbage containers may be free standing or recessed units. Openings in garbage containers should be located between 900-1000 mm above the floor.

h. Color Contrast: Color contrast should be provided between accessories and surrounding surfaces.

3.2.18.4 Illustrations

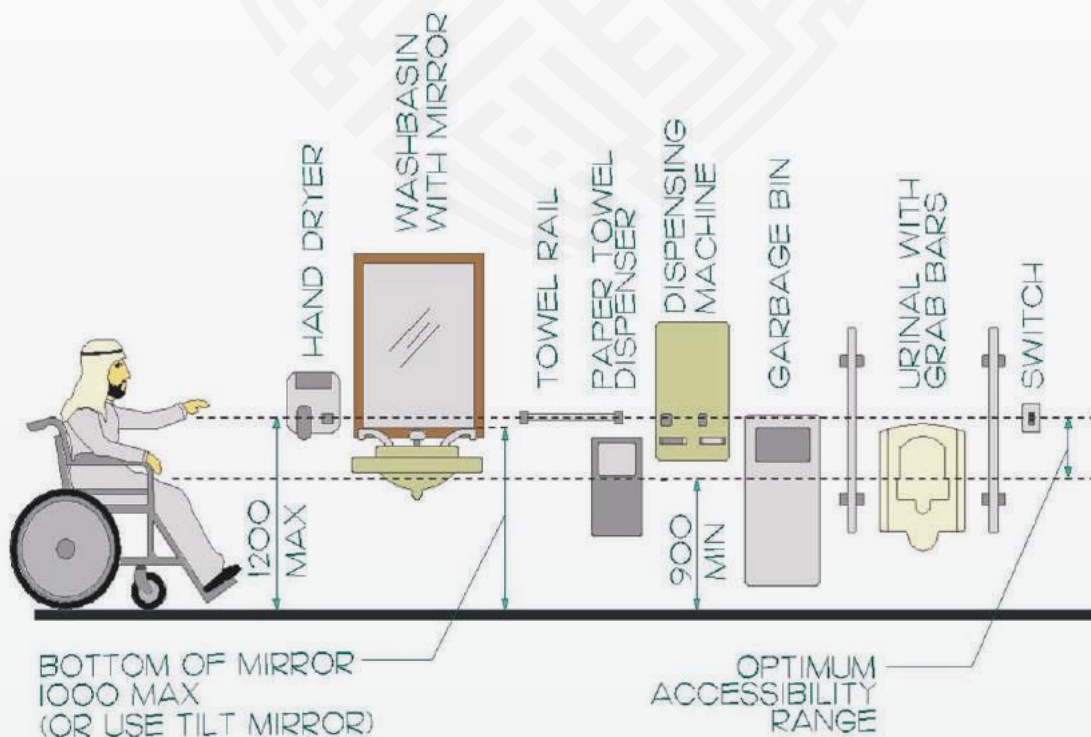

Figure 153: Washroom Accessories



3.2.18.5 Other Considerations

- 2.2 Anthropometric Data
 - 3.2.26 Overhanging and Protruding Objects
 - 3.3.10 Controls and Operating Mechanisms
- Appendix B Illumination
Appendix B Texture and Color





3.2.19

Bathtubs

3.2.19.1 Design Considerations

Bathtubs should be designed with safety in mind. Walk-in tubs are safer and more accessible than standard bathtubs. Slip-resistant surfaces and grab bars reduce slipping hazards, while accessible operating systems address limitations in reach, and hand strength and dexterity.



Figure 154: Bathtub

Showing an accessible bathtub with a slip resistant transfer pad, vertical and horizontal grab bars, and a hand held shower head on a sliding vertical bar allowing maximum flexibility.

3.2.19.2 Application Guidelines

All bathtubs should comply with this section.

If it is technically infeasible to have all bathtubs in a bathing facility comply with this section, at least 10%, but never less than one, of the bathtubs should comply with this section.



3.2.19.3 Technical Guidelines

a. General: Accessible bathtubs should be located on an accessible route that complies with Section 3.2.2.

b. Clear Floor Space: A clear floor space should be provided adjacent to the open side of the bathtub. The clear floor space should be a minimum of 900 mm deep and should extend the full length of the tub plus the length of clear floor space required adjacent to transfer benches. Clear floor space adjacent to the transfer bench measuring a minimum of 900 mm wide x 750 mm deep should be provided at the end of an accessible bathtub. A washbasin is permitted to overlap the transfer space no more than 300 mm, provided required clear floor space that complies with Section 3.2.16 is provided. (Figure 155)

c. Grab Bars: With the exception of freestanding bathtubs, all accessible bathtubs should be equipped with two grab bars. The first grab bar should be located on the side wall, adjacent to the longest side of the tub, and the second located on the wall at the foot end of the tub. The side grab bar, shaped like an inverted letter “T”, should include a horizontal member that is at least 1200 mm long and a vertical member that is at least 800 mm long and centred on the horizontal member. The side grab bar should be mounted so that the horizontal member is positioned 800 mm above the floor and the vertical member is positioned 300 mm away from the head end, toward the foot end of the tub. The end grab bar, located on the foot end wall, should measure at least 1200 mm long and be mounted vertically. The vertical grab bar should be positioned 100 mm away from the edge of the tub, toward the side wall, with its lowest end at 200 mm above the bathtub. All grab bars should also comply with Section 3.2.21. (Figures 155, 156 and 157)

d. Transfer Bench: A transfer bench should be provided at the head end of an accessible bathtub with the top of the bench level with the top of the tub. It should extend the full width of the tub, measure a minimum 400 mm deep and. The seat surface should be non-slip, smooth without rough edges, and should have a minimal sloped towards the bathtub, not steeper than a 1:50 ratio, to drain accumulated water. (Figure 155)

e. Faucets and Controls: An accessible bathtub should have two faucet controls; the first to control water to the bath spout should be centred on the foot-end of the tub, located with its centreline no higher than 450 above the top of the tub. The second to control water to the shower should be mounted on the side wall below the horizontal component of the side grab bar, 100 mm from the end of the grab bar closest to the foot end of the tub. Faucet control handles should be of the long lever type, but not spring-loaded. The controls should be equipped with a thermostatic-mixing or pressure-equalizing valve in compliance with Section 3.3.10. The water temperature of



the water supply should not exceed 55 degrees Celsius. Controls and faucets should be color contrasted with the surrounding tub and its enclosure surfaces. The hot and cold settings should be simple and intuitive to understand and set. *(Figures 156 and 157)*

f. Shower Head: The shower faucet control located at the side of the tub should be connected to a shower head with at least 1500 mm of flexible hose that can be used both as a fixed position shower head and as a hand held shower head. The shower head should comply with appropriate parts of Section 3.3.10 and have an on/off control. It should be mounted on a vertical bar, adjustable from a height of 1000 mm upwards above the floor. The vertical bar should be installed 100 mm towards the foot end of the tub, from the end of “T” shaped grab bar. The vertical bar for the shower head should be designed as a grab bar in compliance with Section 3.2.21. *(Figures 156 and 157)*

g. Soap Holders: Two recessed soap holders should be provided at accessible bathtubs; one should be located so that it can be reached from a seated position within the tub that provides reach ranges complying with Section 2.2, and the other located higher so that it can be reached from a standing position. *(Figure 156)*

h. Emergency Call Strip: A waterproof emergency call strip should be provided at all accessible bathtubs. The emergency strip should be located on the wall adjacent to the longest side of the tub, and positioned 75 mm above the bathtub beginning 150 mm away from the corner of the side wall, near the head of the tub. Emergency call strips should be color and texture contrasted with surrounding surfaces. Emergency call strip activation should be monitored from a location within the facility. *(Figure 156)*

i. Surface: All interior surfaces of the bathtub should be slip resistant.

j. Bathtub Enclosures: Enclosures for bathtubs should not obstruct controls, interfere with a person transferring into/out of a tub, or have tracks mounted on the bathtub rim. Shower curtains that do not obstruct the clear floor space in front of the tub are permitted. Shower curtain rods where used should be reinforced and attached securely to resist displacement if grabbed.

k. Illumination Levels: Illumination levels in the bath tub area should be at least at 200 lux.

l. Color Contrast: There should be pronounced color contrast between wall/fixtures/controls, wall/grab bars, and wall/washroom accessories.



3.2.19.4 Illustrations

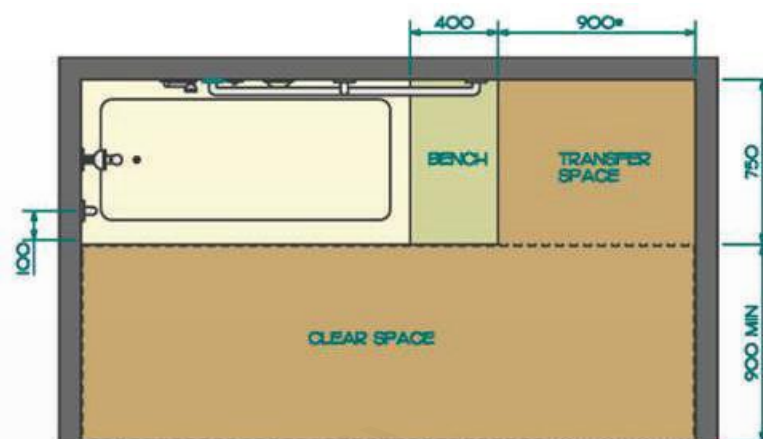

Figure 155: Bathtub

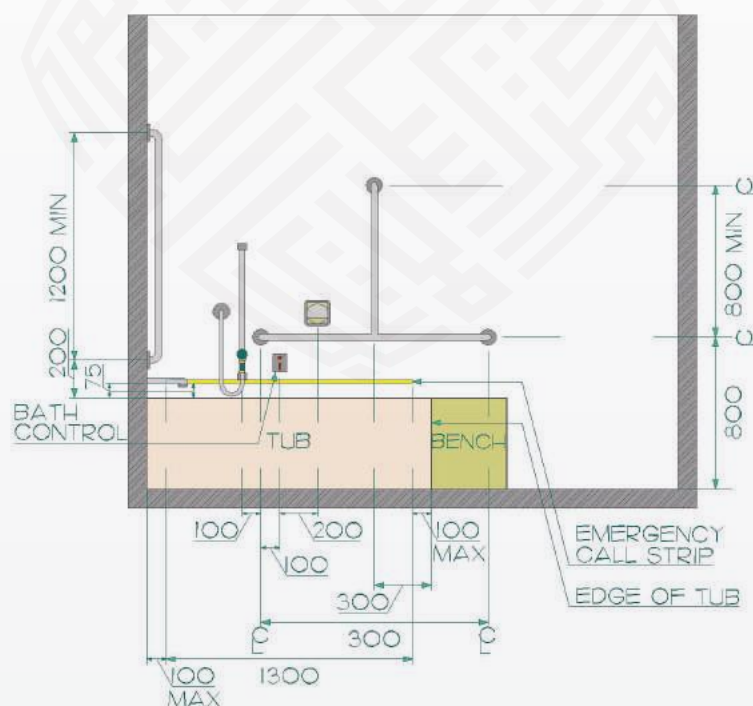

Figure 156: Bathtub

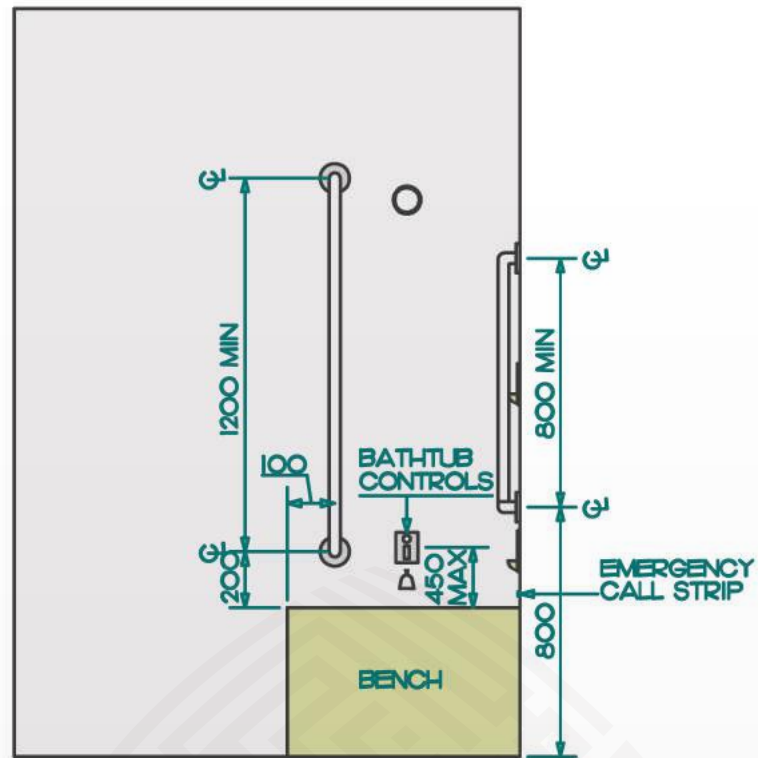

Figure 157: Bathtub

3.2.19.5 Other Considerations

- 2.2 Anthropometric Data
- 3.2.18 Toilet Accessories
- 3.2.21 Grab Bars
- 3.3.10 Controls and Operating Mechanisms
- Appendix B Illumination
- Appendix B Texture and Color



3.2.20

Showers

3.2.20.1 Design Considerations

For people who use wheelchairs or other mobility devices in the shower, roll-in or kerbless-type shower stalls eliminate the obstructive nature of thresholds and minimise tripping hazards. Accessible showers should always be equipped with grab bars and non-slip materials to ensure the safety of all users. Hand-held showerheads and folding benches may be useful to some people with disabilities. For people with a visual impairment, contrasting colors should be used to differentiate between the shower stall and equipment.

3.2.20.2 Application Guidelines

Showers should comply with this section.

In a renovation situation if it is technically infeasible to have all showers comply with this section, at least 10% of showers, but never less than one, in each bathing facility should comply with this section.

3.2.20.3 Technical Guidelines

a. Location: Shower stalls should be located on an accessible route that complies with Section 3.2.2.

b. Clear Floor Space: A clear floor space that is as wide as the shower entrance and extends a minimum of 900 mm in depth should be provided adjacent to the exterior of accessible shower entrances. Fixtures and accessories may project into the clear floor space, provided that they do not interfere with access or create a hazard. The interior of a shower stall should have a minimum clear floor area measuring at least 1500 mm wide and 900 mm deep. Where feasible, the interior shower stall dimensions should be increased to a minimum of 1500 x 1500 mm. (Figure 158)

c. Floor Surface: Floor surfaces located at the interior and exterior of shower stall entrances should be slip-resistant. Floor slopes for drainage in the shower areas should not exceed a ratio of 1:50. Shower stall drains should be located below the shower seat or to one side of the floor area in the stall. Openings in floor drains should not exceed 13 mm in any direction. The use of trench drains in accessible showers should be avoided. In renovation situations where it is technically infeasible to avoid the use of trench drains, trench drains should be covered with grates that have no openings that exceed 13 mm in any direction and should be level with the adjacent floor surface.



d. Threshold: Shower stalls should have a maximum threshold of 13 mm above the floor that complies with Section 3.2.25. Thresholds that are level with adjacent floors are desired.

e. Shower Seat: A seat should be provided in an accessible shower stall. Shower seats should be mounted on a side wall and should be capable of being folded against the wall. They should not be spring loaded. The shower stall seat should be 450 mm deep and extend the full width of the stall, less the space required for a shower curtain to close. The shower stall seat should be color contrasted from its surroundings, and have a smooth non-slip surface containing no rough edges. The top surface of the seat should be positioned between 425-475 mm above the shower floor. The shower stall seat should be designed to carry a minimum load of 1.33 kN. (Figures 158, 159 and 160)

f. Grab Bars: All accessible shower stalls should be equipped with two grab bars. The first grab bar should be located on the side wall, adjacent to the longest side of the shower interior, and the second grab bar located on the same wall as the shower seat. The side grab bar should be of a cranked design, possessing a horizontal component 300 mm long, a 45 degree angled component 300 mm long and a vertical component 300 mm long. The side grab bar should be mounted with the centreline of its horizontal component 800 mm above the shower stall floor and beginning 150 mm away from the side wall that contains the shower seat. The entry grab bar, located on the same wall as the shower seat, should measure at least 1200 mm in length and should be mounted vertically. The vertical grab bar should be positioned 100 mm away from the outside edge of the stall, toward the side wall, with its lowest surface 200 mm above the shower seat. All grab bars should also comply with Section 3.2.21. (Figures 158, 159 and 160)

g. Water Control Valve: Pressure-equalizing or thermostatic-mixing water control valves should be installed in accessible shower stalls that comply with Section 3.3.10, for example a single lever operated control. Controls should be color contrasted to the surrounding walls. The hot and cold settings should be kept simple and intuitive to understand and adjust. The controls for the shower should be located on the same wall containing the “cranked” grab bar. The shower control valve should be positioned so that it is aligned with the front edge of the shower seat and so that it is no higher than 1000 mm above the stall floor. (Figure 159)

h. Soap Holders: Shower stalls should have two recessed soap holders provided one above the other. One soap holder should be capable of being reached from a seated position that provides reach ranges complying with Section 2.2, and the other from a standing position. The lower soap holder should be positioned beneath the cranked grab bar and should be a maximum of 600 mm away from the wall containing the seat. (Figure 159)



i. Shower Head: Shower heads provided in accessible shower stalls should be moveable, i.e. hand-held, but should also be able to be set at a fixed position. Shower heads should have a flexible hose attached that is a minimum of 1500 mm long. Shower heads should be attached to a vertical bar that complies with requirements for grab bars and that is located 300 mm away from the wall containing the shower seat. The shower head should be adjustable in height and position from 1000 mm and above, measured from the stall floor. Shower heads should include an on/off control that complies with Section 3.3.10. (*Figure 159*)

k. Shower Stall Enclosures: Access to shower controls and transfer into/out of the shower stall should not be impeded by the shower stall enclosure. Shower curtains that do not obstruct the clear floor space in front of the shower are preferred to the use of shower doors. Where shower curtain rods are used they should be reinforced and attached securely to resist displacement if grabbed.

l. Illumination Levels: The Illumination levels in the shower stall should be at least at 200 lux.

m. Emergency Call Switch: A waterproof emergency call strip-switch should be provided within shower stalls, located on the same wall containing the shower control. Emergency call strips should be positioned no higher than 300 mm above the stall floor and should extend to no more than 150 mm away from each end wall.

The strip-switch should be color contrasted with the surrounding surfaces. Activation of the emergency call switch should be monitored from a location within the facility. (*Figure 159*)

n. Heat Lamp or Radiant Panel: Heat lamps and Radiant Panels should be considered for installation in areas that are in close proximity to the exterior of shower stalls to assist users in drying off.

o. Color Contrast: There should be pronounced color contrast between wall/fixtures/controls, wall/grab bars, and wall/washroom accessories.



3.2.20.4 Illustrations

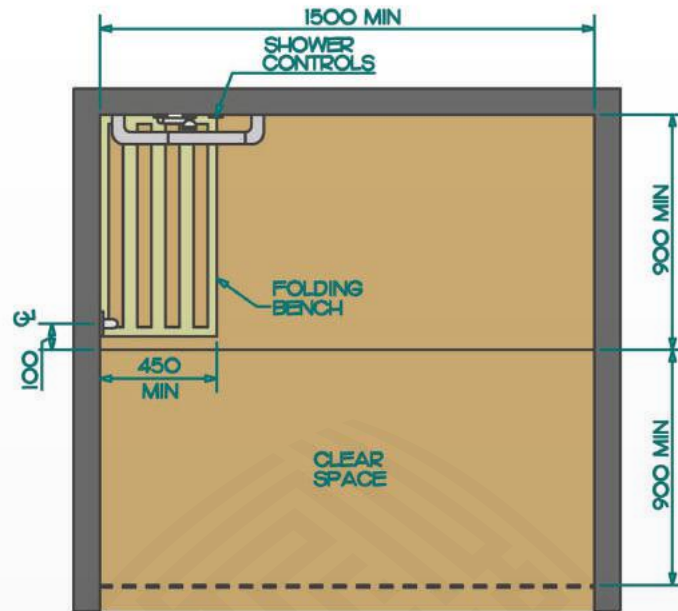

Figure 158: Shower Stall

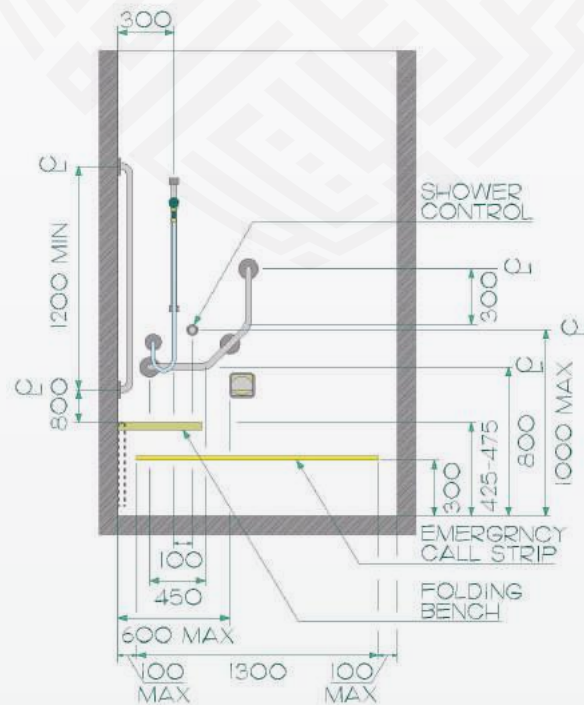

Figure 159: Shower Stall

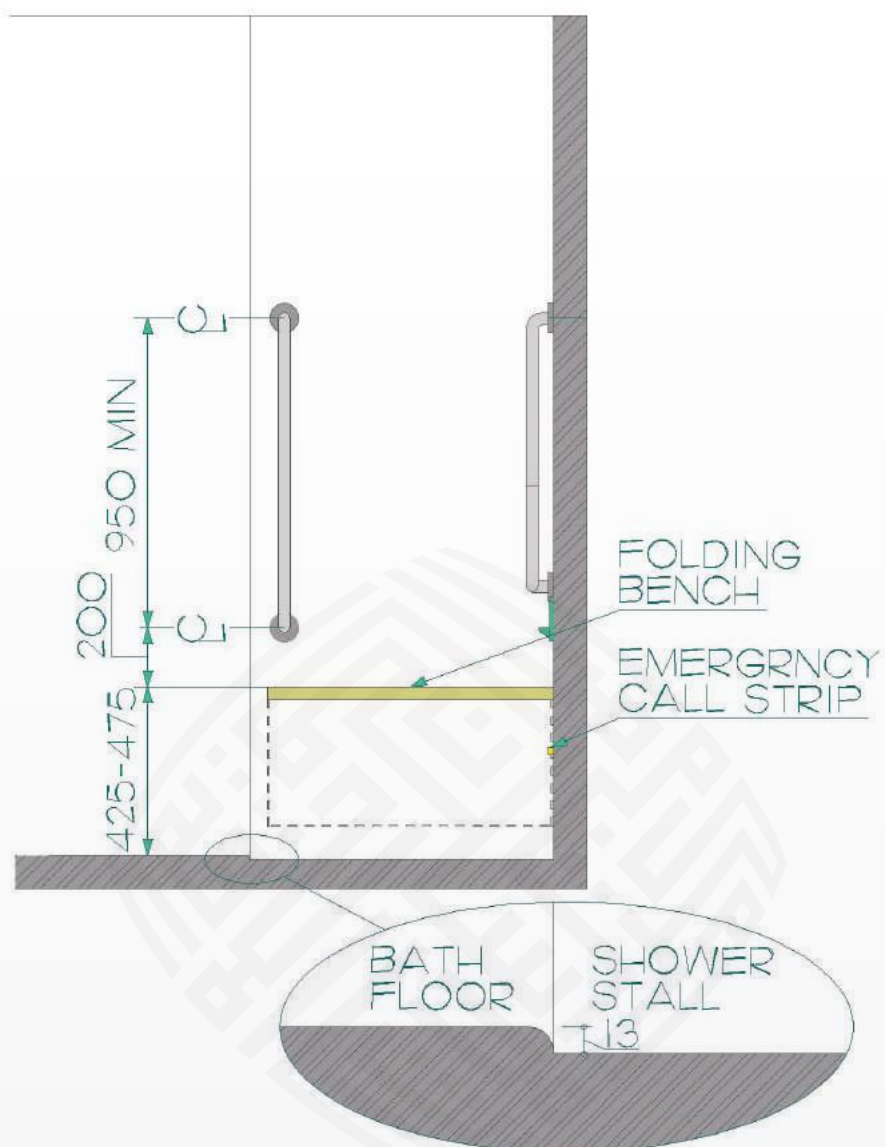

Figure 160: Shower Stall

3.2.20.5 Other Considerations

- 2.2 Anthropometric Data
- 3.2.11 Toilet Accessories
- 3.2.21 Grab Bars
- 3.3.10 Controls and Operating Mechanisms

- Appendix B Illumination
- Appendix B Texture and Color



3.2.21 Grab Bars

3.2.21.1 Design Considerations

For people who require assistance in standing up or sitting down, or who need stability while standing, grab bars are an important part of an accessible environment. Grab bars should be easy to grasp for users with large or small hands, and they should have a surface that is slip-resistant. Secure attachment of grab bars is a critical safety requirement.

3.2.21.2 Application Guidelines

All grab bars should comply with this section.

3.2.21.3 Technical Guidelines

- a. Diameter:** Grab bars should be 30-40 mm in diameter.
- b. Structural Strength:** Grab bars should be capable of resisting a load of at least 1.3 kN applied in any direction when installed.
- c. Surfaces:** Grab bars should have a slip-resistant surface, be free of any sharp or abrasive elements, and be color contrasted with surrounding environment. Adjacent surfaces should be free of any sharp or rough elements.
- d. Clear Space:** Grab bars should have a clearance of 35-45 mm between the inside surface and wall it is mounted on.

3.2.21.4 Illustrations

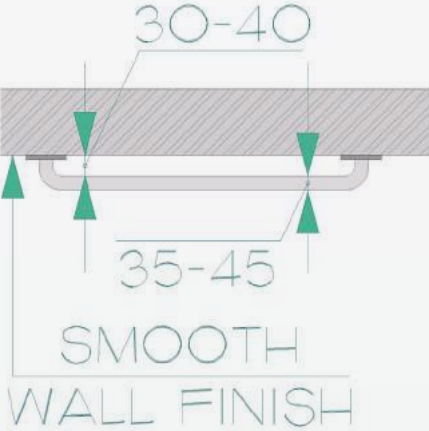

Figure 161: Grab Bars



3.2.21.5 Other Considerations

2.2 Anthropometric Data

3.2.11 Toilet Facilities

3.2.17 Urinals

3.2.19 Bathtubs

3.2.20 Showers

Appendix B Illumination

Appendix B Texture and Color





3.2.22

Offices, Work Areas and Meeting Rooms

3.2.22.1 Design Considerations

Offices providing services or programs to the public should be accessible to all, regardless of mobility or functional profile. Office and related support areas should also be accessible for both staff and visitors that may have varying levels of ability.

A quiet acoustic environment benefit all people, but particularly those with a hearing impairment. –Any background noise from mechanical equipment such as fans should be minimal. Telephone equipment with volume adjustment for individuals who are hard of hearing should be provided.

Tables and workstations should allow wheelchair and seated users the necessary knee and equipment space . Circulation area design needs to allow for the larger spatial needs of larger mobility equipment including mobility scooters.

Full spectrum task lighting is a design feature that will help all users, especially people with vision impairments. In locations where reflective glare is a problem, such as where large expanses of glass with reflective flooring are found, blinds that can be louvered upwards should be considered.

3.2.22.2 Application Guidelines

Offices, work areas, or meeting rooms meant for use by the general public, employees, clients, or customers should comply with this section.

3.2.22.3 Technical Guidelines

a. Location: Offices, work areas and meeting rooms that are provided for use by the staff, customers, clients, or the general public they should be located on an accessible route that complies with Section 3.2.2.

b. Doors: Where offices, work areas and meeting rooms are equipped with a door, the door should comply with Section 3.2.9.

c. Identification: Offices, work areas and meeting rooms should be identified with signage that complies with Section 3.4.1.

d. Clear Floor Area: Each office, work area and meeting room should incorporate a clear floor space that complies with Section 2.2 that allows a person using a mobility device to complete a 180-degree turn.



e. Accessible Route: Within each office, work area and meeting room space there should be an accessible route connecting primary activity areas that complies with Section 3.2.2. Accessible routes in offices, work areas and meeting rooms should not require a person using a mobility device to travel backwards, or require them to leave or re-enter the space, to travel along the accessible route.

f. Storage: Where storage, shelving or display units are provided in offices, work areas and meeting rooms, access to these facilities should be provided that complies with Section 3.3.9.

g. Equipment and Controls: Access to office and presentation equipment, writing surfaces, switches and controls in offices, work areas and meeting rooms should be provided that comply with Sections 3.3.6 and 3.3.10. Clear floor space that complies with Section 2.2 should be provided adjacent to all office equipment.

h. Knee and Toe Clearances: Surfaces in offices, work areas and meeting rooms should incorporate knee and toe space beneath that comply with Section 2.2.

i. Ambient Noise: Fans, lights and other devices should not, or should not be located so that they do not, create background or ambient noise that can interfere with hearing and communication.

j. Illumination: Offices, work areas and meeting rooms should incorporate even Illumination throughout the space of at least 100 lux. Where reading is required, or may occur, task lighting with a minimum of 200 lux should be provided.

3.2.22.5 Other Considerations

- 2.3 Anthropometric Data
- 3.2.2 Routes, Corridors and Access Aisles
- 3.2.10 Windows, Glazed Screens and Sidelights
- 3.2.25 Ground and Floor Surfaces
- 3.3.6 Tables, Counters and Work Surfaces
- 3.3.9 Storage, Shelving and Display Units
- 3.3.10 Controls and Operating Mechanisms
- 3.4.8 Visual Alarms
- 3.4.7 Assistive Listening Systems

Appendix B Glare and Light Sources

Appendix B Illumination

Appendix B Materials and Finishes Appendix B Texture and Color

Appendix B Acoustics



3.2.23

Kitchens and Kitchenettes

3.2.23.1 Design Considerations

The design of kitchens, kitchenettes and coffee stations should incorporate an appropriate level of access for people with disabilities. There should be adequate manoeuvring space for people with wheelchairs or mobility devices to approach and use counters, appliances, elements and storage. When a frontal approach is used, generally at work surfaces and appliances, knee and toe space is required. A side approach is preferred for refrigerators.

The various elements of the kitchen environment should be marked with contrasting colors to aid people with visual impairments locate surfaces, appliances and controls. Whenever possible, work surfaces should be dark to increase object visibility.

3.2.23.2 Application Guidelines

Kitchens, kitchenettes, and coffee stations generally used by the public and/or staff should comply with this section. Kitchen facilities located in commercial kitchens are not required to comply.

At least 50% of shelf and storage space located in, or associated to, kitchen facilities should comply with this section.

3.2.23.3 Technical Guidelines

a. Pass-Through Kitchens: Pass-through kitchens should have two points of entry. In the kitchen area, a minimum clear width of 1200 mm should be provided between the leading surfaces or edges of cabinets, counter tops, appliance or walls that are located opposite each other. (Figures 162 & 164)

b. U-Shaped Kitchens: In the area of a U-shaped kitchen, a minimum clear width of 2100 mm should be provided between leading surfaces or edges of opposing cabinets, counter tops, appliances, or walls. In a renovation situation where it may be technically infeasible to provide the required minimum clear width, the clear width may be reduced to 1500 mm. (Figure 163)

c. Storage Elements: Storage in kitchen areas should be located on an accessible route that complies with Section 3.2.2, provide space for access and reach that complies with Section 2.2, and incorporate operable elements that comply with Section 3.3.10. (Figure 165)

d. Clear Floor Space: A minimum clear floor space of 800 mm wide x 1400 mm deep should be provided adjacent to storage, cabinets, sinks, appliances, and work surfaces to permit forward and/or side approach.



e. Kitchen Work Surfaces: Accessible kitchen work surfaces should be located on an accessible route that complies with Section 3.2.2, provide clear floor space for a forward approach, and knee and toe spaces beneath that comply with Section 2.2. The height of work surfaces or counter tops should be free of sharp or abrasive surfaces, should be located between 725-850 mm above the floor, and should be color contrasted with adjacent surfaces or elements.

f. Kitchen Sinks: Kitchen sinks should be located on an accessible route that complies with Section 3.2.2 and provide clear floor space for a forward approach. Kitchen sinks should incorporate knee and toe space beneath that complies with Section 2.2. The height of the rim on a surface mounted sink, or the counter top with an under-mounted sink, should be 710-856 mm above the floor. Kitchen sinks should include faucets and other controls that comply with Section 3.3.10 and reach requirements of Section 2.2. Water supply and drain pipes located under sinks should be insulated or otherwise configured to protect against contact and be free of sharp or abrasive surfaces. *(Figure 166)*

g. Kitchen Appliances: Kitchen appliances should be located on an accessible route that complies with Section 3.2.2 and provide adjacent access space that complies with Section 2.2. Kitchen appliances should incorporate controls and operable portions that comply with Section 3.3.10, with the exception of appliance doors and door latching devices.

h. Dishwashers: Dishwashers should incorporate a clear floor space adjacent to the dishwasher door measuring a minimum of 800 mm wide by 1400 mm deep. The dishwasher door, when in the open position, should not obstruct the clear floor space required to access the dishwasher or the sink.

i. Ranges and Cook-tops: Ranges and cook-tops should incorporate controls that are positioned to prevent reaching over or across the heating surface. Controls should comply with Section 3.3.10. Where a forward approach is required to access the range or cook-top, knee and toe space beneath that complies with Section 2.2 should be provided. Heat emitting appliances should be insulated or otherwise configured to prevent burns, abrasions, or shock to users. When ranges or cook-tops are located within facilities where children are typically present, e.g. a facility operating children's' programs, ranges and cook-tops should be equipped with a safety switch or other device that disengages the appliance controls.

j. Ovens: Ovens should have controls located on the front panels, mounted no higher than 1400 mm above the floor. Where a side-hinged oven door is used, a work surface should be provided adjacent to the latch side of the door and a pull-out shelf should be provided below the oven. Where a bottom-hinged oven door is used, a work surface should be provided adjacent to one side of the door. When ovens are located within facilities where children are typically present, e.g. a facility operating children's' programs, ovens should be equipped with a safety switch or other device that disengages the appliance controls. *(Figure 168)*



k. Refrigerators & Freezers: Refrigerators and/or freezers should be configured so that a minimum of 50% of the provided refrigerator and/or freezer space is a maximum of 1370 mm above the floor. A clear floor space should be provided adjacent to the front of refrigerators and/or freezers to allow a parallel approach, and should be positioned with the centre-line of the clear floor space at a maximum distance of 600 mm away from the front surface of the refrigerator/freezer. (Figure 169)

l. Color Contrast: Kitchen elements should incorporate color contrast to visually differentiate the cabinets and appliances from adjacent wall and floor surfaces, the countertop from the cabinets and adjacent walls, and operable hardware on cabinets.

3.2.23.4 Illustrations

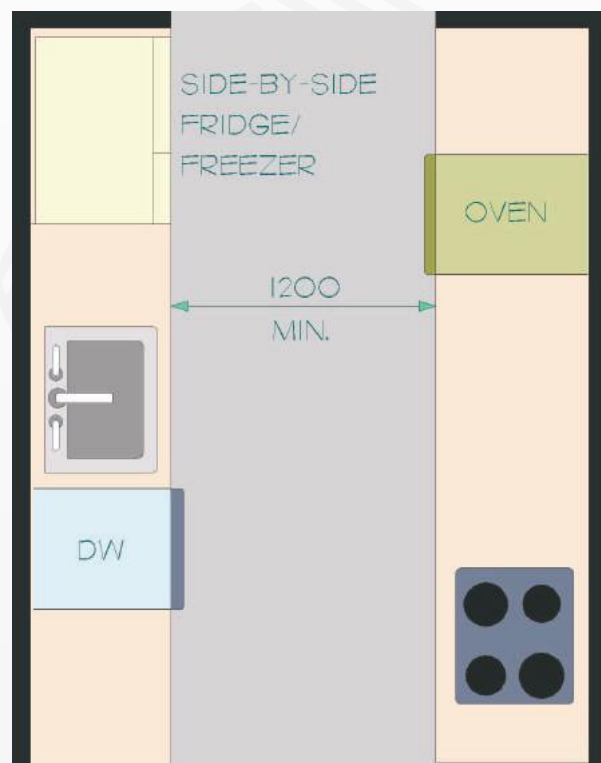

Figure 162: Pass-Through Kitchen

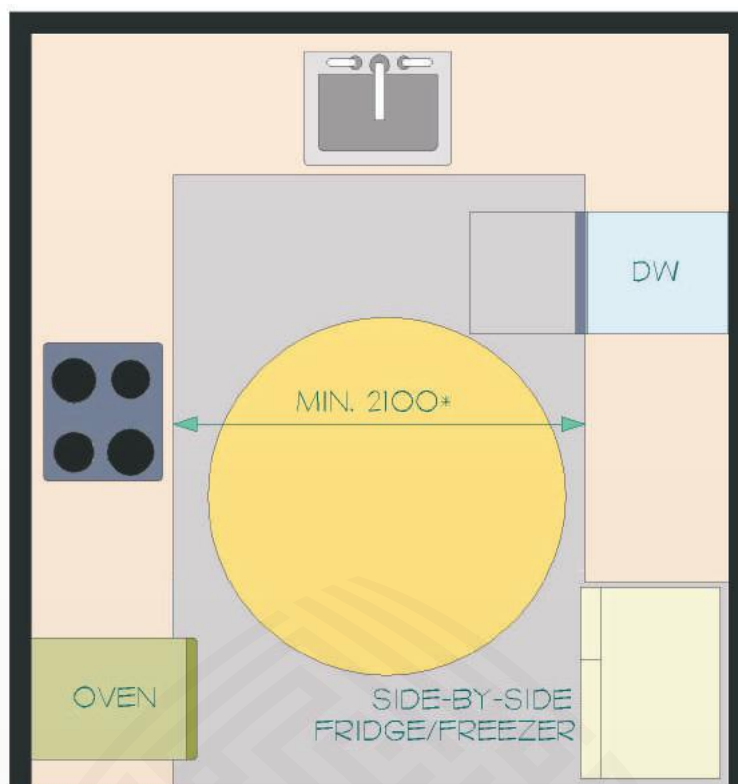

Figure 163: U-Shaped Kitchen

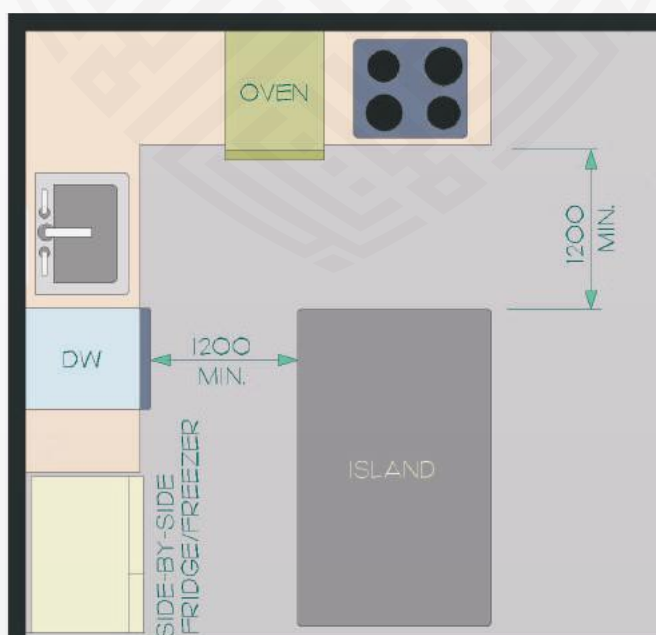

Figure 164: L-Shaped Kitchen with Island

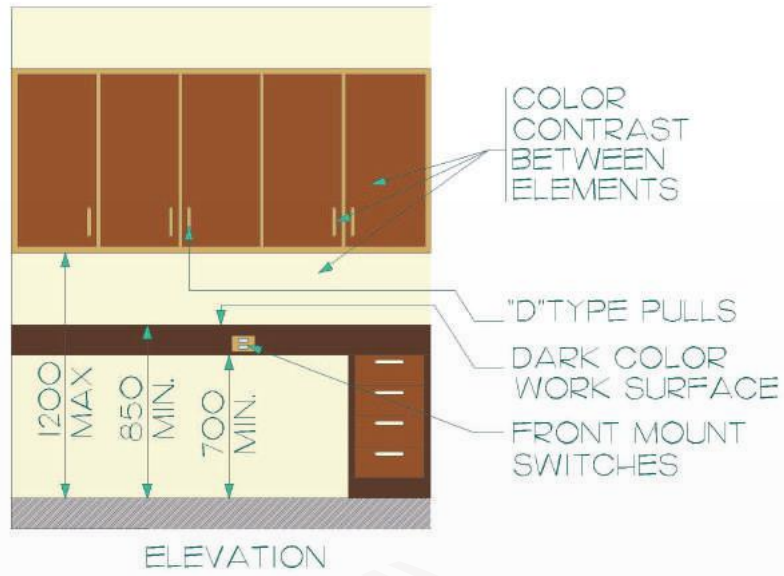

Figure 165: Storage Elements

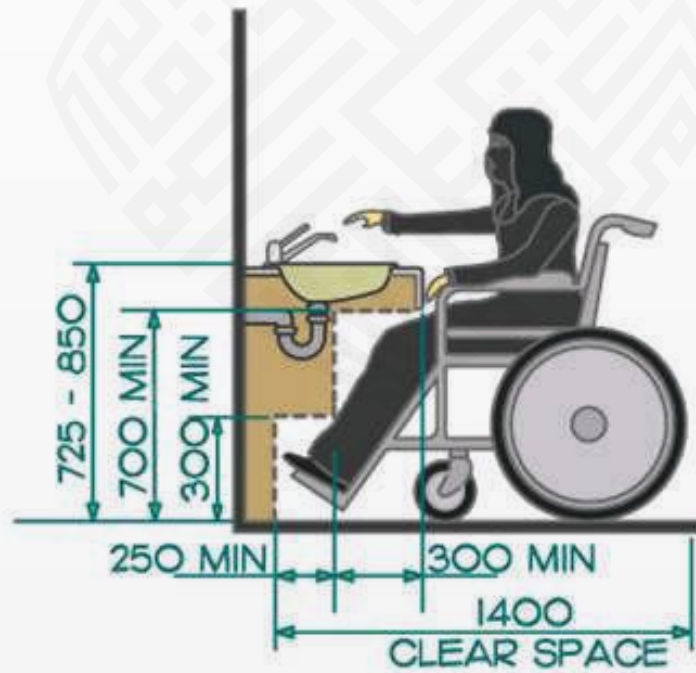

Figure 166: Kitchen Sink

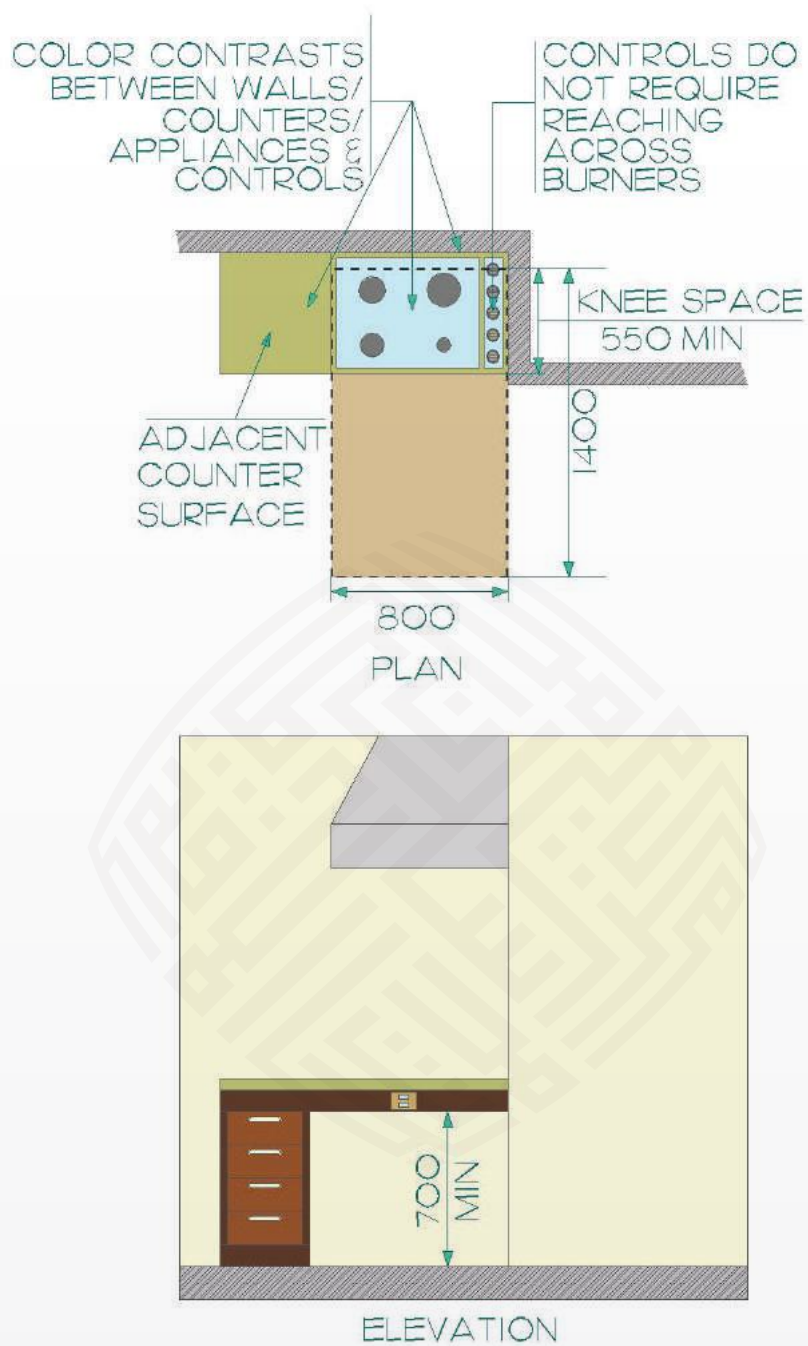

Figure 167: Cook Top

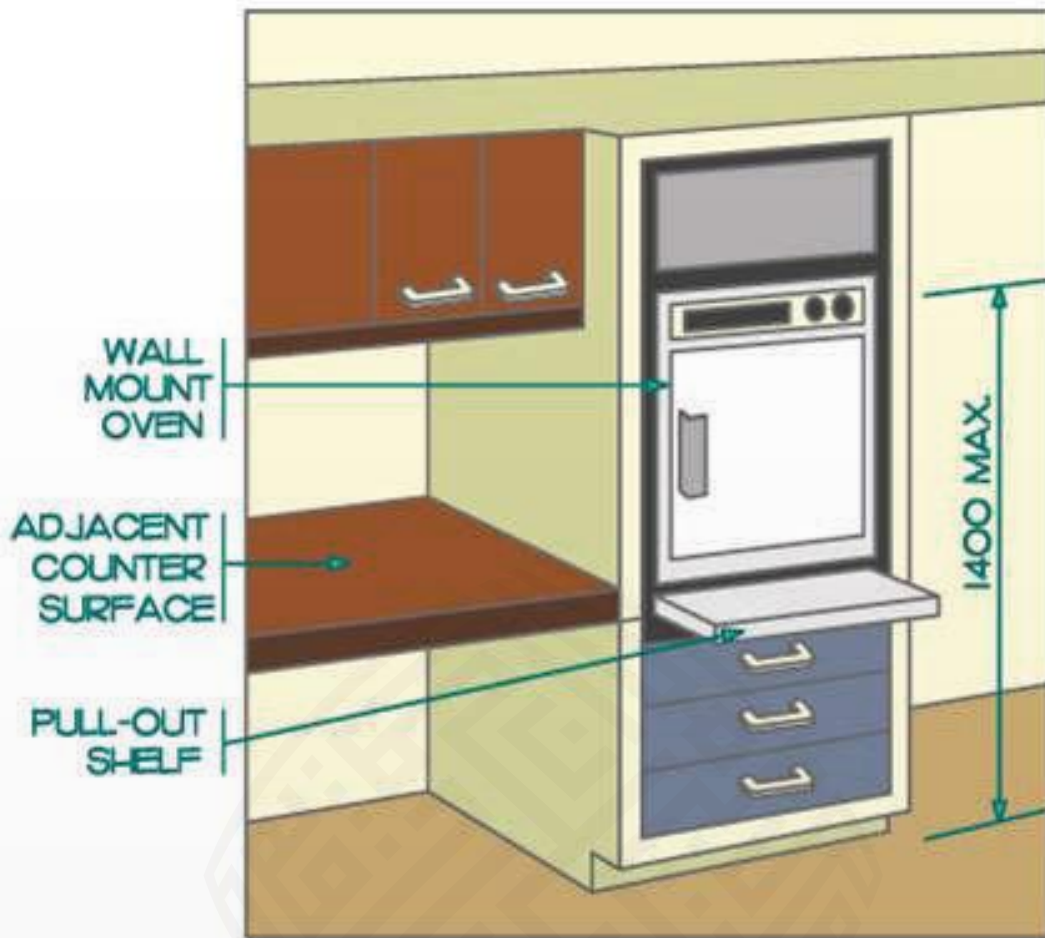
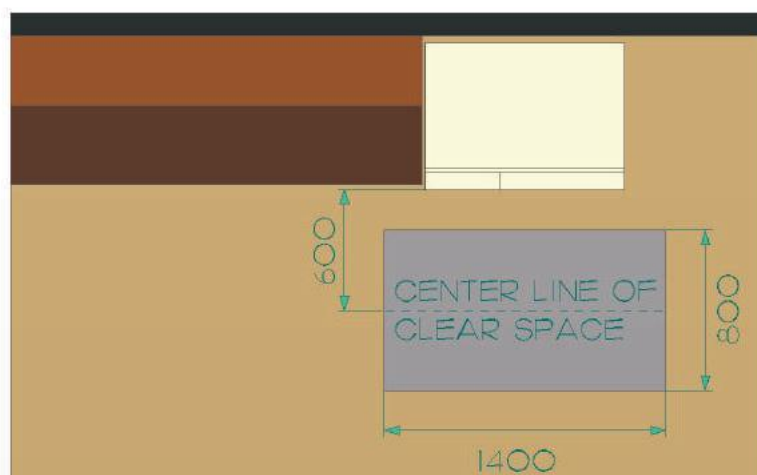
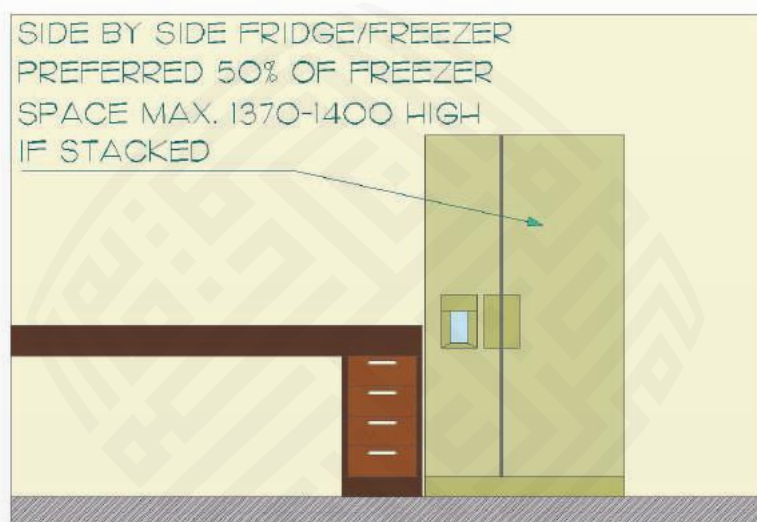

Figure 168: Built-In Oven



PLAN



ELEVATION

Figure 169: Fridge/Freezer Wall

3.2.23.5 Other Considerations

- 2.3 Space and Reach Requirements
- 3.1.3 Protruding and Overhead Objects
- 3.1.3 Routes, Corridors and Access Aisles

- 3.4.12 Glare and Light Sources
- 3.4.13 Illumination
- 3.4.14 Materials and Finishes
- 3.4.15 Texture and Color



3.2.24

Dressing Rooms

3.2.24.1 Design Considerations

Where common-use dressing rooms are provided in a facility, at least one private accessible dressing room should also be provided. This is useful where an attendant or a parent is assisting a child or a person with a disability. Sufficient space should be provided for two people and a wheelchair. Facilities should include a stable change bench, grab bar to assist with transfers to the bench, and accessories such as a mirror and coat hooks.

Handrails in dressing rooms and along circulation routes from dressing rooms to pools, gymnasiums and other activity areas will benefit many facility users.

3.2.24.2 Application Guidelines

All common-use dressing rooms used by the general public, employees, patients, or customers should comply with this section. In a renovation situation where it is technically infeasible to have all dressing rooms in compliance with this section, a minimum of 10% of dressing rooms, but never less than one, for each type of use in each set of dressing rooms, should be accessible and comply with this section.

At least one private accessible dressing room should be provided within accessible change rooms at pools and gymnasiums.

3.2.24.3 Technical Guidelines

a. Location: Accessible dressing rooms should be located on an accessible route that complies with Section 3.2.2. Accessible facilities provided within accessible dressing rooms should also be located on an accessible route that also complies with Section 3.2.2.

b. Doors: Where doors are provided for entry to or within accessible dressing rooms, they should comply with Section 3.2.9.

c. Clear Floor Space: A clear floor space should be provided within accessible dressing rooms that allows a person using a mobility device to complete a 180-degree turn complying with Section 2.2. Door swings should not overlap the required clear floor space. A clear turn space is not required where the dressing room is accessed through a curtained opening of at least 1200 mm wide, and where a clear floor space, that allows for a 180-degree turn to be completed, is located adjacent to the dressing room.



d. Bench: At least one bench designed to carry a minimum load of 1.33 kN should be provided within each accessible dressing room. Benches should measure a minimum of 750 mm deep by 1800 mm wide. Benches should be securely fixed to the wall at its longest side. Bench seating surfaces should be located between 450-500 mm above the floor. Clear floor space should be provided adjacent to the bench for a parallel approach.

e. Coat Hooks: Where coat hooks are provided in dressing rooms, at least two accessible coat hooks shall be provided adjacent, but not directly above, each accessible bench. Accessible coat hooks should be collapsible, mounted no higher than 1200 mm above the floor, and should project a maximum of 50 mm from the wall surface it is mounted to.

f. Mirrors: Where mirrors/reflective surfaces are provided, at least one mirror/reflective surface should measure a minimum of 450 mm wide by 1400 mm high and should be positioned to allow viewing by people who are either seated or lying on the bench and for people standing in front of the mirror/reflective surface.

g. Illumination: Illumination throughout dressing rooms should be consistent and no less than 200 lux.

h. Showers, Pools, and Saunas: Floor surfaces in dressing rooms provided in conjunction with swimming pools, showers or other wet locations, should be slip-resistant and designed to prevent the accumulation of standing water. The seating surface of benches in wet areas should also be slip-resistant and designed to prevent the accumulation of water.

i. Handrails: Handrails which comply with the requirements of Section 3.3.13 should be provided along routes connecting accessible dressing rooms to activity areas.

j. Grab Bars: An “L”-shaped grab bar that complies with Section 3.2.21 should be provided in each dressing room. Grab bars should be located on a wall that is beside the bench. The horizontal and vertical members of the “L”-shaped grab bar should measure at least 750 mm long each. The grab bar should be positioned with the centerline of the horizontal member located between 625-700 mm above the floor and with the centerline of the vertical member 150 mm in front of the bench’s leading edge.



3.2.24.4 Illustrations

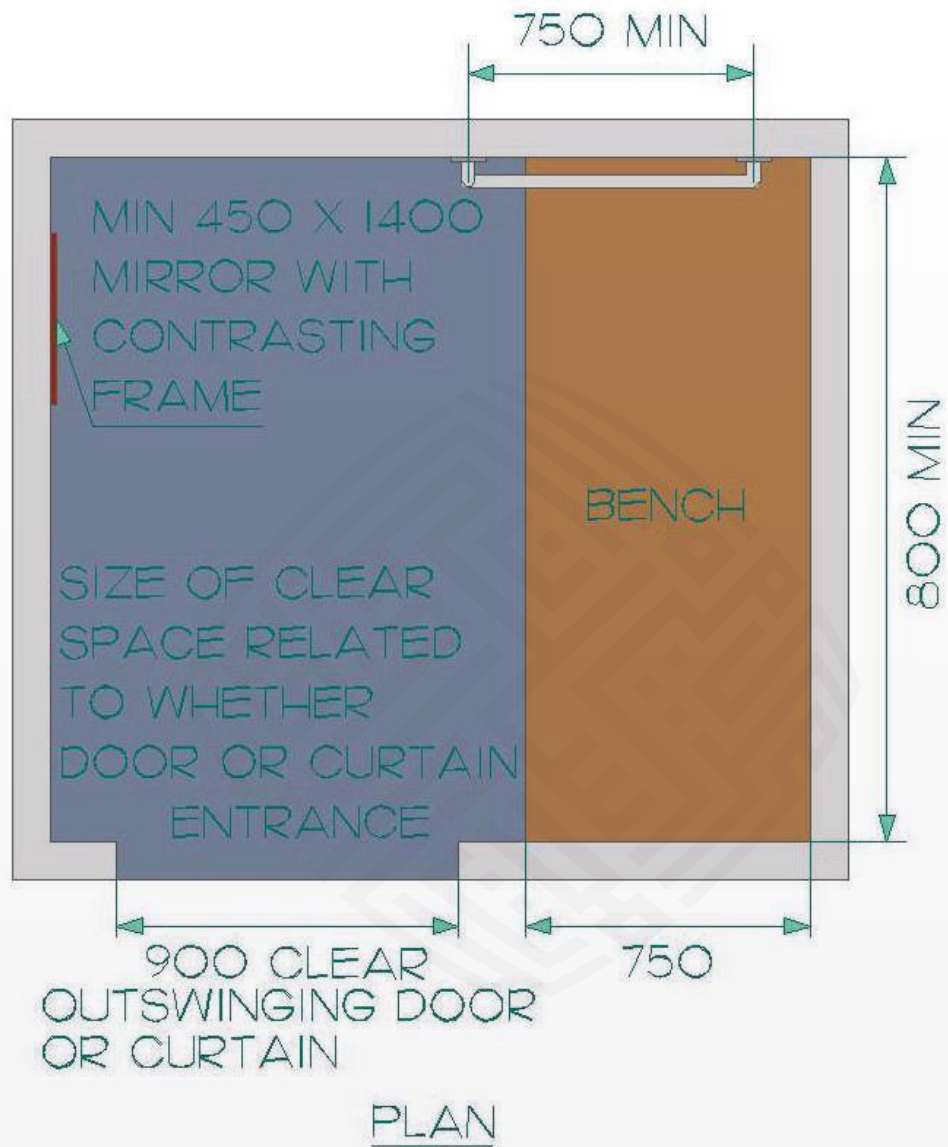

Figure 170: Floor Plan of Dressing Rooms

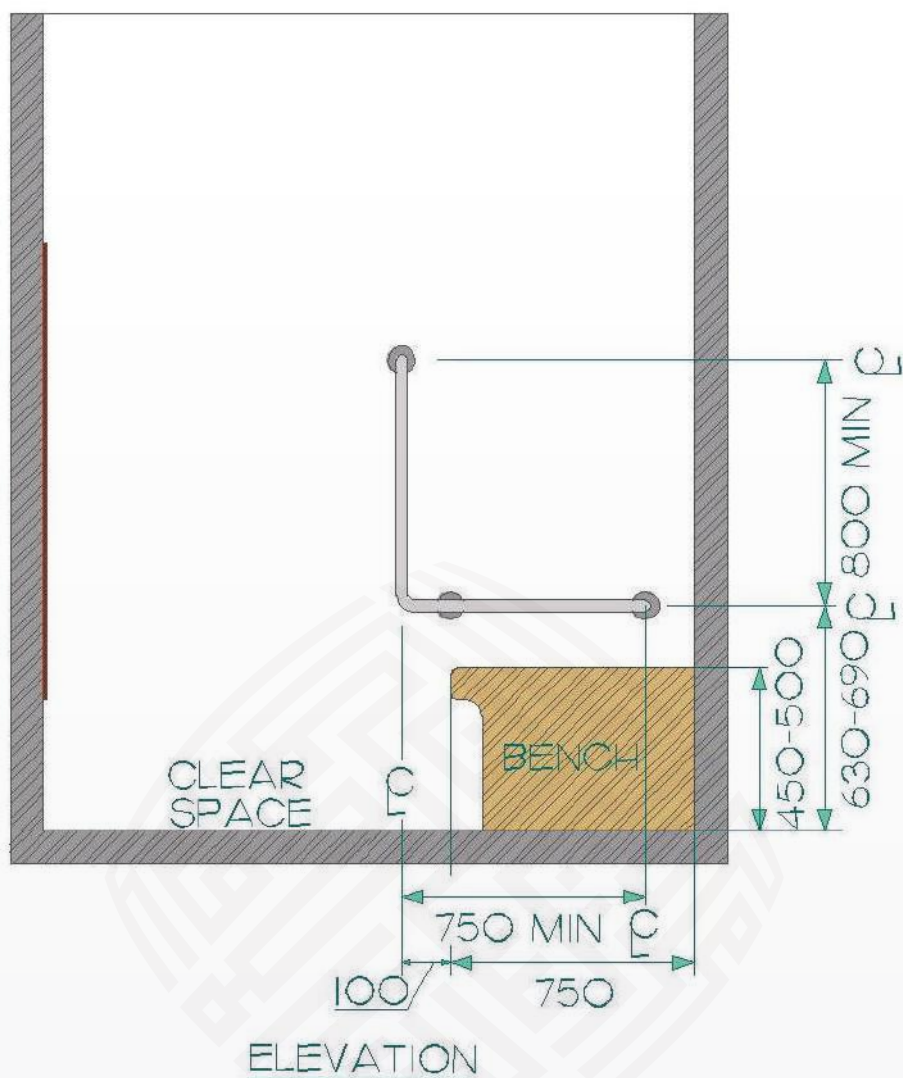

Figure 171: Section at Dressing Room Bench

3.2.24.5 Other Considerations

- 2.2 Anthropometric Data
- 3.2.2 Routes, Corridors and Access Aisles
 - 3.2.21 Grab Bars
 - 3.2.25 Floor Surfaces
 - 3.2.26 Overhanging and Protruding Objects
- 3.3.13 Handrails



3.2.25 Floor Surfaces

3.2.25.1 Design Considerations

The choice of flooring materials has a considerable impact on people using all kinds of mobility aids, as well as, people with low vision. The choice of material and the process of installation can facilitate or hinder the movement of people around a facility, and an unsuitable floor surface is a problem for all users.

Floor finishes, such as carpet, should be implemented so that people using wheelchairs, walkers, or other mobility aids can travel over them without using undue energy or encountering tripping hazards. Glare-free floor surfaces can not only be uncomfortable, but it can also create a visual obstacle especially for people with visual impairments. Safe floor surfaces are slip-resistant and glare-free.

3.2.25.2 Application Guidelines

Floor surfaces used in all areas and routes frequented by staff and the public should comply with this section.

3.2.25.3 Technical Guidelines

a. Floor Surfaces: Floor surface should glare-free, stable, firm, and slip-resistant. Floor materials should not be heavily patterned.

b. Changes in Level: Except for lifts and other elevating devices which should comply with Sections 3.2.5 - 3.2.8, changes in level should comply with Figures 172, 173 and 174. Further requirements apply to other elements as follows: Ramps (Section 3.1.4) and Stairs (Section, 3.1.5).

c. Carpet: Carpet should be low-level loop construction, made using 10 or 12-gauge non-static fibres and should be directly glued to the sub-floor that it rests on.

Vertical Rise	Edge Treatment
0 to 6 mm	May be vertical
7 to 13 mm	Bevelled, but not steeper than the ratio of 1:2 (50%)
Over 13 mm	Not steeper than the ratio of 1:16 (6.25%) and treated as a sloped floor, ramp or kerb cut



3.2.25.4 Illustrations

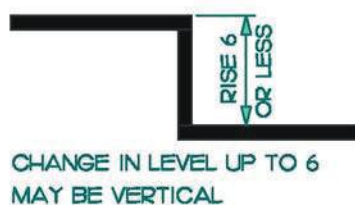

Figure 173: Changes in Level up to 6

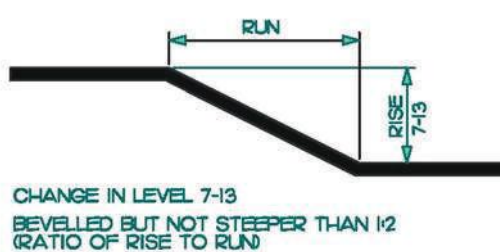

Figure 174: Changes in Level between 7 and 13 mm

3.2.25.5 Other Considerations

- 3.2.1 Entrances
- 3.2.2 Routes, Corridors and Access Aisles
- 3.2.3 Ramps
- 3.2.4 Stairs
- 3.2.5 Escalators
- 3.2.6 Lifts
- 3.2.7 Inclined and Vertical Platform Lifts
- 3.2.11 Toilet Facilities
- 3.2.22 Office, Work Areas and Meeting Rooms
- 3.2.24 Dressing Rooms

Appendix B Glare and Light Sources



3.2.26 Overhanging and Protruding Objects

3.2.26.1 Design Considerations

Overhead and protruding objects along corridors, access routes and entranceways are hazardous to both sighted and non-sighted people. Any design feature positioned above the detection range of a long white cane, such as the underside of a staircase or a drinking fountain, poses a potential threat of injury to people with a visual impairment or an individual distracted by a conversation. Likewise, protruding objects at low levels also present tripping and injury hazards where they cannot be detected.

All freestanding obstacles require warning surfaces to alert all facility users to their presence.

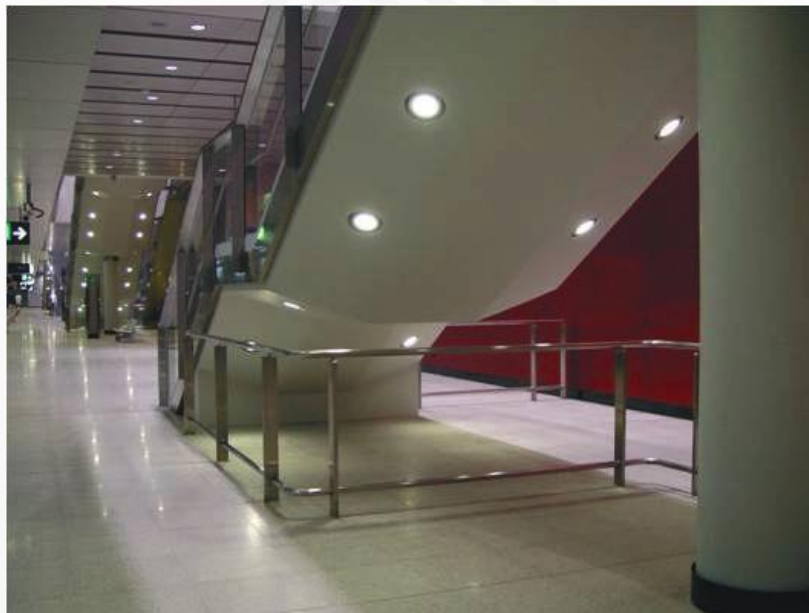

Figure 175: Detectable Barrier

Detectable barrier guards area below stairs where headroom is low



Figure 176: Detectable Handrail

Handrail extensions are cane detectable.

3.2.26.2 Application Guidelines

All objects projecting from a wall, ceiling, or other location should comply with this section.

3.2.26.3 Technical Guidelines

a. Protruding Objects: Objects extending from walls that have a leading edge located between 650 - 2100 mm above the floor should not protrude more than 100 mm into pedestrian routes. Objects extending from a wall may protrude by any amount if the leading edge is at or below 650 mm above the floor. (*Figures 177 and 178*)

b. Freestanding Objects: Where overhanging or protruding elements on freestanding objects are between 650 - 2100 mm above the ground, they should not encroach more than 300 mm into pedestrian areas. The bottom edge of a freestanding object, with a space of more than 300 mm between supports, should not be more than 650 mm above the floor or ground.

c. Width Maintenance: The width of accessible routes and manoeuvring space should not be reduced by protruding objects.

d. Headroom: The minimum clear height for headroom in pedestrian areas should be 2100 mm. The preferred clear height doorways should be 2100 mm, but a clear height of 1980 mm is acceptable. (*Figure 178*)



e. Overhead Hazard: Where the headroom along an accessible route has been reduced to less than 2100mm, a detectable guard, guardrail, or other barrier shall be provided such that the leading edge is at or below 680mm above the floor. Where guards are used they should be firmly fixed and have color contrasted solid or horizontal railings. (Figure 179)

f. Detectable Ground Surface: A tactile and color contrasted warning surface should be provided where overhead or protruding hazards exist. The detectable surface should be located flush with the surrounding walking surface and extend at least 300 mm outward around the entire overhead or protruding hazard.

g. Color Contrast: The leading edge of a protruding or overhanging object should be color contrasted to its background and surroundings to enhance the visibility of the hazard.

h. Walkway Widths for People Using Crutches: Walkways and corridors utilised by people using crutches typically require 810-920 mm clear width. Where walkways are expected to be utilised by people using crutches, no obstructions or projections should be placed lower than 300 mm above the floor (Figure 5).

i. Detection Space for People Using a Long White Cane: People who use a long white cane to help them manoeuvre, can detect an obstruction up to 650 mm from the floor or ground. Depending on the person, the forward detection range can vary from 900-1500 mm. (Figure 7)

j. Detection Space for People Using a Walker: Walkways and corridors utilised by a person using a walker typically require 710 mm clear width. (Figure 6)

3.2.26.4 Illustrations

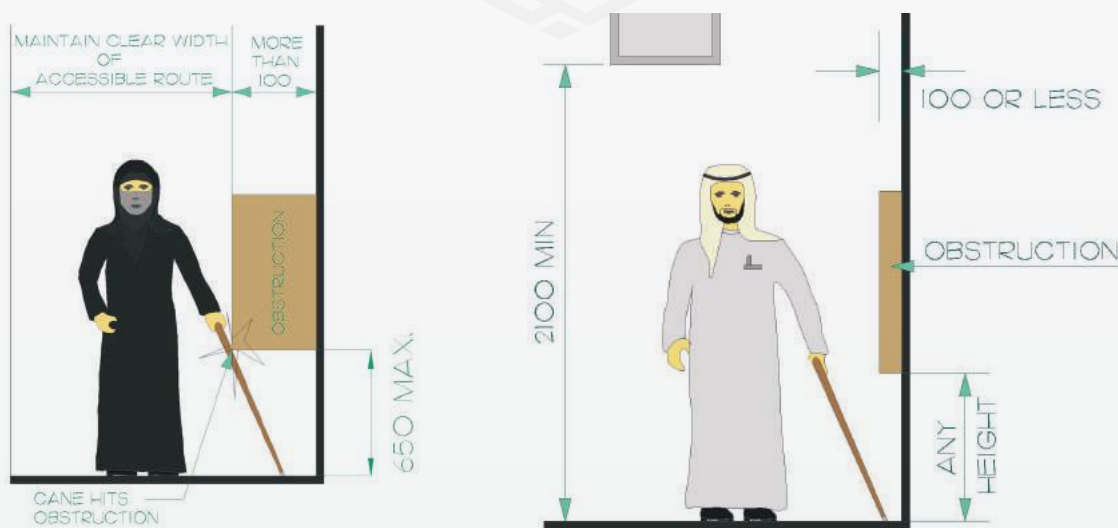

Figure 177: Limits of Protruding Objects Figure 178: Limits of Protruding and Overhanging Objects

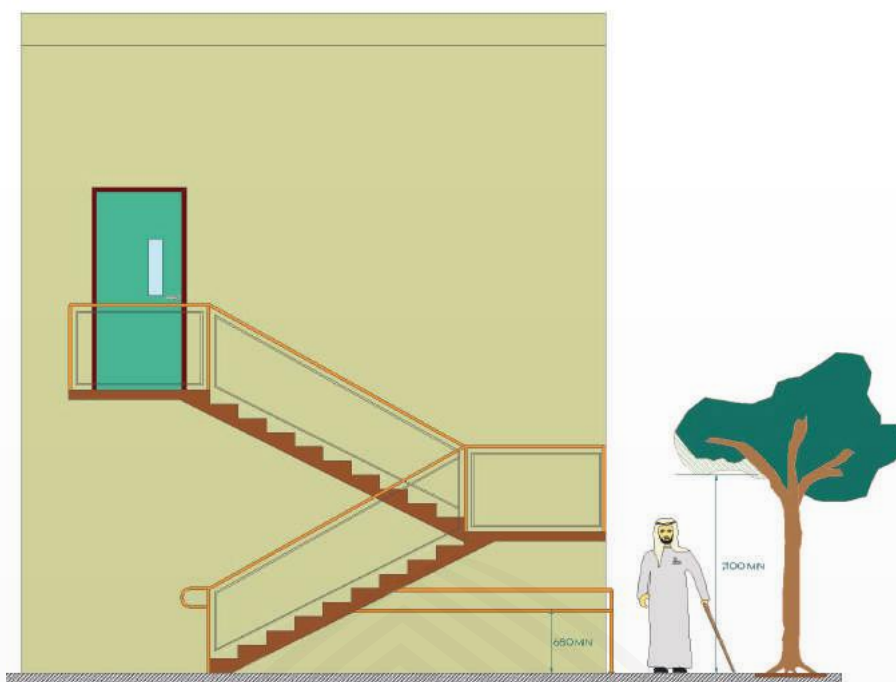

Figure 179: Overhead Obstructions

3.2.26.5 Other Considerations

3.1.3 Sidewalks, Pavements, Paths and Routes

3.4.6 Detectable Warning Surfaces

Appendix B Materials and Finishes

Appendix B Texture and Color



3.2.27 Gates, Turnstiles and Openings

3.2.27.1 Design Considerations

Gates, turnstiles and openings should be designed to accommodate a range of individuals with varying abilities. For children, people of short stature and people who use wheelchairs or mobility scooters, the height of single-bar gates corresponds to their face or neck. People using canes or crutches and those with poor balance will have difficulty negotiating a revolving turnstile, while people who use wheelchairs will be unable to traverse a turnstile at all. An adjacent opening of an accessible width is recommended to address the needs of people with wheelchairs, mobility devices, strollers, walkers or delivery carts.



Figure 180: Turnstiles

Showing an example of an integrated accessible turnstile, using color and signage.

3.2.27.2 Application Guidelines

All gates, turnstiles, and openings should comply with this section

3.2.27.3 Technical Guidelines

a. Gates or Openings to Public Use Areas: Gate or openings to public use areas should have a minimum clear width of 900 mm. Where closing devices are installed at gates or openings they should not be spring loaded, and any hardware installed should comply with Section 3.3.10. Gates should be cane-detectable and comply with Section 3.2.26.



b. Turnstiles or Other Ticketing Control Devices: Where turnstiles or other ticket controlled devices are installed, an accessible gate or opening should be provided in close proximity. Accessible gates or openings should be identified using the international symbol of accessibility (*Figure 182*).

c. Color Contrast: Contrasting colors should be used to differentiate turnstiles from the surrounding environment. At gates and openings, contrasting color should be provided on either side of at the supporting members or posts.

3.2.27.4 Illustrations

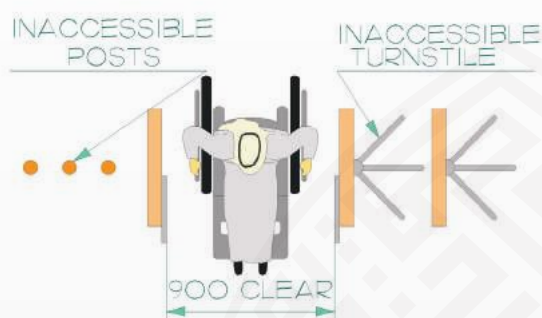

Figure 181: Access at Turnstile

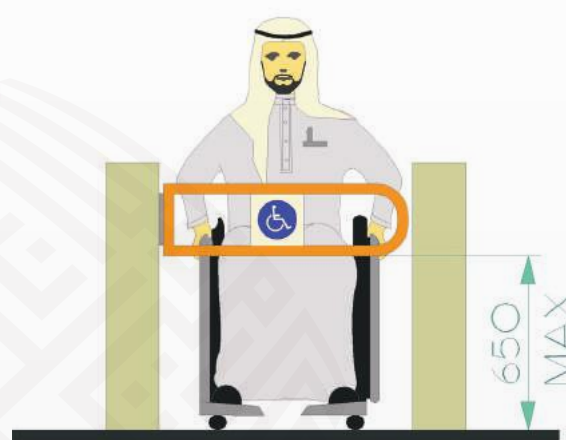
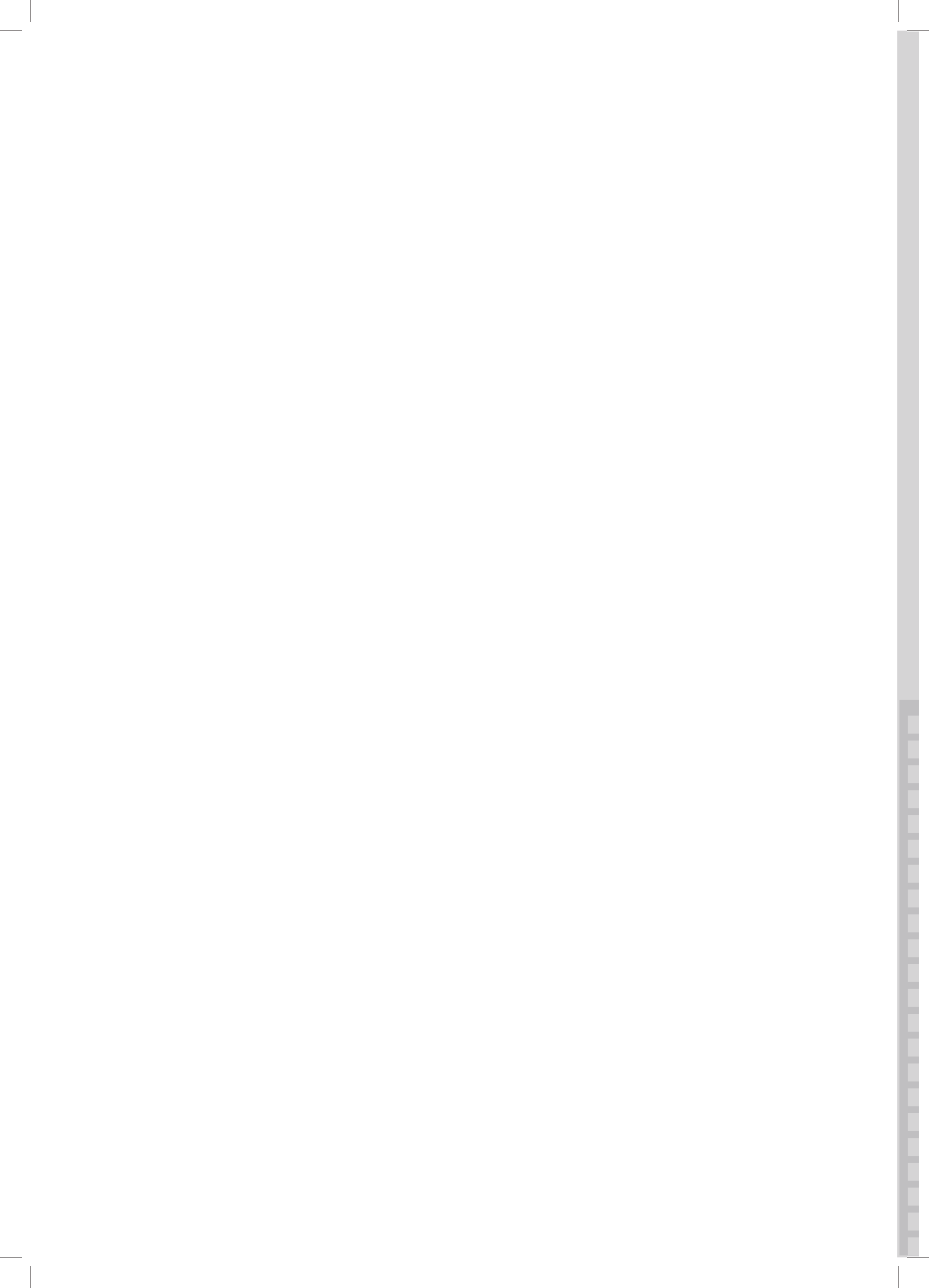

Figure 182: Access at Turnstile

3.2.27.5 Other Considerations

- 2.2 Anthropometric Data
- 3.2.9 Doors
- 3.2.10 Windows, Glazed Screens and Sidelights
- 3.3.10 Controls and Operating Mechanisms
- 3.4.1 Signage
- 3.4.4 Information Systems
- 3.4.5 Card Access, Safety and Security Systems



3.3 UABE TECHNICAL & DESIGN GUIDELINES

Amenities

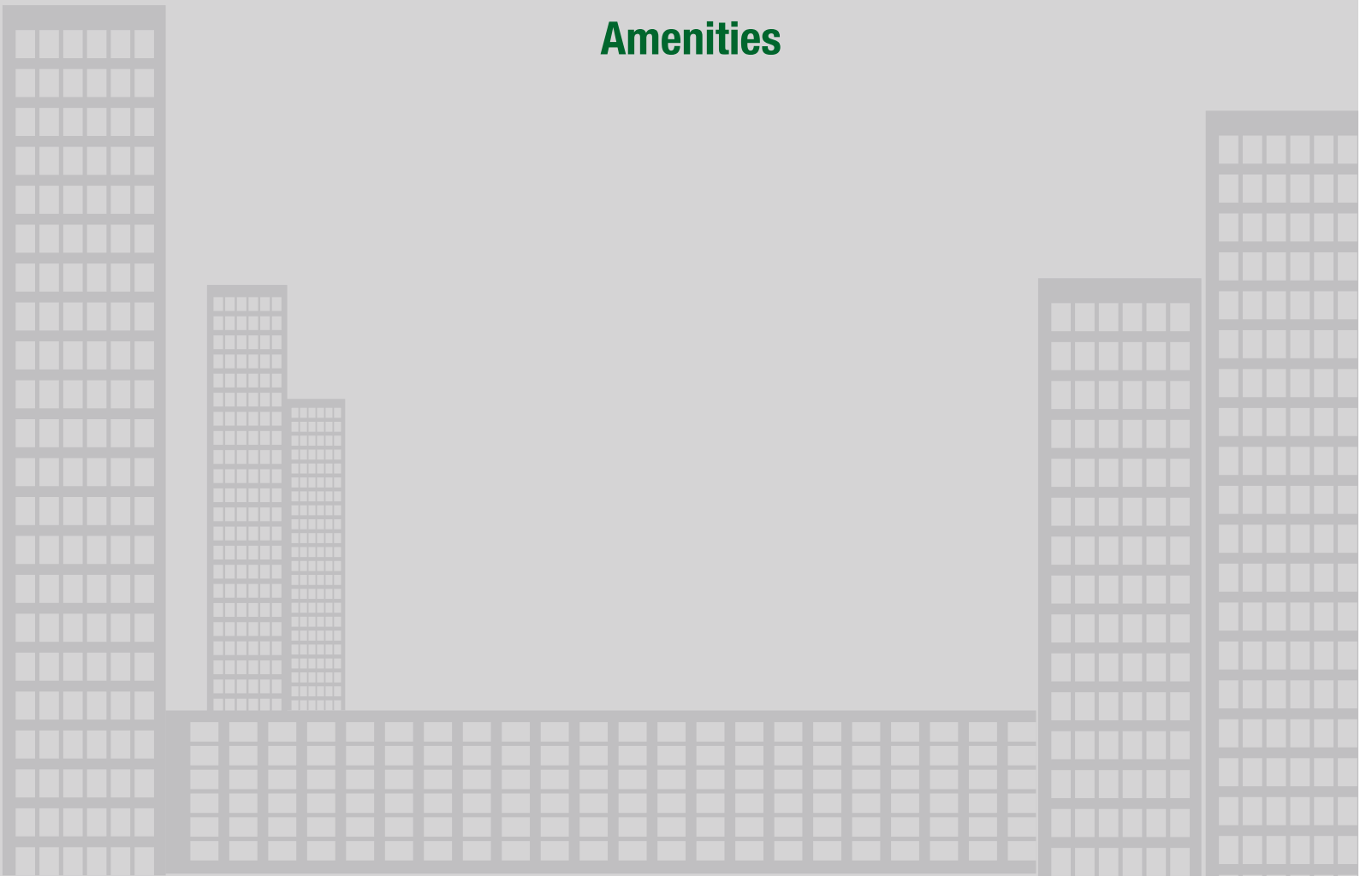



3.3

AMENITIES

3.3.1

Information, Reception & Service Counters

3.3.1.1 Design Considerations

All people should have access to information, reception and service counters, regardless of mobility or functional profile. It is recommended that a lower counter be provided for people using a mobility device, or children, or people short in stature, or people with balance problems that may require seating. However, other users may require a taller design, and it is preferable to incorporate a selection of counter heights into information, reception and service areas. The choice of heights should include speaking ports and writing surfaces.

The depth of counters should account for the provision of knee and toe space for people using a wheelchair or mobility scooter.

For people with visual impairments, the use of color contrast, tactile difference or audio landmarks (e.g., receptionist voice or music source) provide navigational cues to the location of service counters or speaking ports.

3.3.1.2 Application Guidelines

At least one section of all counters used for reception, or for providing information or service should comply with this section.

3.3.1.3 Technical Guidelines

a. Location: Information, reception and service counters should be located on accessible routes that comply with Section 3.1.3 for exterior locations, and Section 3.2.2 for interior locations.

b. Waiting and Queuing Areas: Waiting and queuing areas associated to service and information counters should comply with Section 3.3.2.

c. Clear Floor or Ground Space: A clear floor space measuring a minimum of 800 mm wide x 1400 mm deep should be provided at accessible sections of information, reception, and service counters for a forward approach.

d. Height: Counters for information, reception or service should incorporate at least one accessible section. Each accessible section of counter should extend for a minimum length of 900 mm. Counter surfaces at accessible sections should be located between 725-850 mm above the floor or ground.



e. Knee and Toe Space: Counters for information, reception, or service should incorporate knee and toe space underneath that complies with Section 2.2.

f. Speaking Ports: Where glazing or other partitions separate opposite sides of a service, information or reception counter, a speaking port should be provided. Speaking ports should be positioned at a maximum height of 1060 mm above the floor.

g. Identification: Methods and systems to identify the location of information, reception or service counters to people with visual impairments should be provided in addition to accessible signage. Examples include; music, auditory cues, tactile pathways.

3.3.1.4 Illustrations

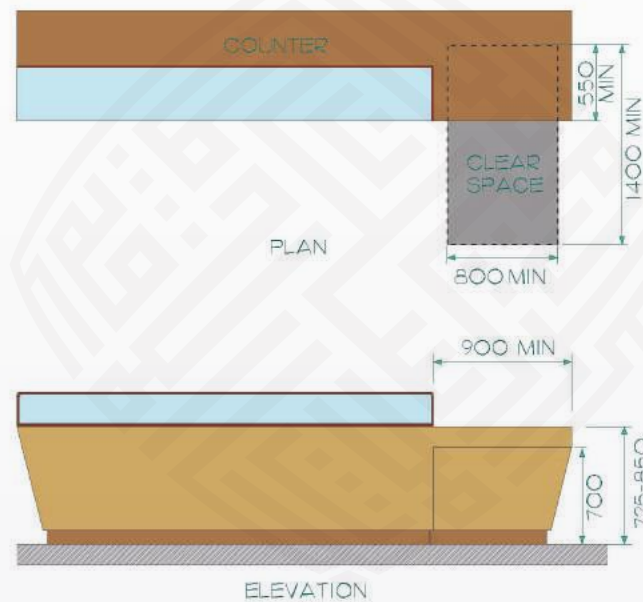

Figure 184: Service Counter

3.3.1.5 Other Considerations

- | | | |
|-------|-------------------------------------|------------------------------------|
| 2.2 | Anthropometric Data | Appendix B Glare and Light Sources |
| 3.2.2 | Routes, Corridors and Access Aisles | Appendix B Illumination |
| 3.4.1 | Signage | Appendix B Materials and Finishes |
| 3.4.3 | Public Address Systems | Appendix B Texture and Color |
| 3.4.4 | Information Systems | Appendix B Acoustics |
| 3.4.7 | Assistive Listening Systems | |



3.3.2 Queuing and Waiting Areas

3.3.2.1 Design Considerations

Queuing and waiting areas for information, tickets, or services should present safe and convenient routes of travel for people who use wheelchairs, mobility scooters, and other mobility devices, as well as, people with a varying range of user ability.

Waiting areas should be designed to accommodate wheelchairs and mobility scooters, and queuing lines that turn corners or double back on themselves should provide adequate space to manoeuvre mobility devices. A by-pass lane or alternative service system should be considered for those people who have difficulty walking and/or standing in queues for long periods. Queuing lines should be marked with handrails to support people with balance problems and guide individuals with visual impairments.

The installation of benches adjacent to waiting or queuing areas is recommended for all users. It is recommended that where people are required to wait in a queue, that a system that allows those that need to sit can do so without losing their place in line.

3.3.2.2 Application Guidelines

All waiting and queuing areas should comply with this section.

3.3.2.3 Technical Guidelines

a. Layout: Guide barriers should be laid out in logical, parallel lines. Layout of queuing areas should include a by-pass lane that is identified with the international symbol of accessibility.

b. Space between Barriers: Guide barriers at queuing areas should be spaced to provide a minimum clear width of 1200 mm between them. Manoeuvring spaces measuring at least 1500 x 1500 mm should be provided at the entrance and exit locations of line-up/queuing areas and at changes of direction along the line-up/queuing route.

c. Barrier Mounting: Guide barriers intended to streamline pedestrian movement should be securely fixed to the floor and should be capable of providing support for waiting persons through the use of rigid rails and/or solid sides. Where floor pockets are installed to support temporary or occasional supports, they should be level with the floor finish and have an integrated cover to prevent tripping hazards.

d. Directional Floor Markings: Where permanent queuing areas are provided the floor should be marked with distinct patterns, colors and/or textures to guide people with a visual impairment.



e. Contrasting Color: Contrasting colors should be used in queuing areas to help differentiate ropes, bars, and solid barriers from the surrounding environment.

f. Cane Detection: Barriers should be cane detectable and should comply with Section 3.2.26.

g. Seating: Seating that complies with Section 3.3.7 should be provided along or immediately adjacent to line-up/queuing area routes.

3.3.2.4 Illustrations

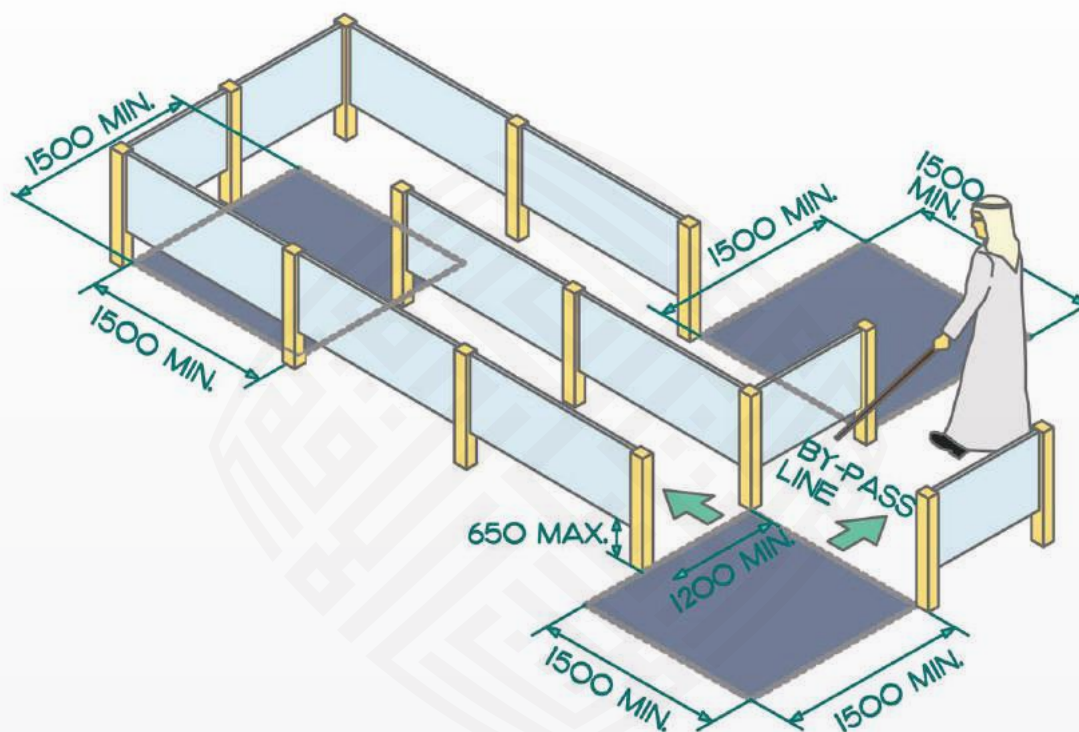

Figure 185: Line-up Area

3.3.2.5 Other Considerations

- | | | |
|--------|-------------------------------------|------------------------------------|
| 2.2 | Anthropometric Data | Appendix B Glare and Light Sources |
| 3.2.2 | Routes, Corridors and Access Aisles | Appendix B Illumination |
| 3.2.25 | Floor Surfaces | Appendix B Materials and Finishes |
| 3.4.1 | Signage | Appendix B Texture and Color |
| 3.4.3 | Public Address Systems | Appendix B Texture and Color |
| 3.4.4 | Information Systems | Appendix B Acoustics |
| 3.4.2 | Public Telephones | |
| 3.4.7 | Assistive Listening Systems | |



3.3.3

Viewing Spaces at Fix Seating

3.3.3.1 Design Considerations

In facilities with fixed seating, there should be reserved viewing/seating areas for those individuals who are unable to use typical seating arrangements. There should always be more than one allocated viewing/seating space, and the design should be able to accommodate the spatial requirements of a mobility device as large as a mobility scooter.

Companion seating should be provided adjacent to the designated areas, and all users should be offered a choice of location and ticket price. Guard rails should be designed to offer people with a wheelchair or mobility device safety without compromising a clear view of the performance area. In addition, aisle seats should be available for people using wheelchairs or mobility scooters who may wish to transfer to an aisle seat.

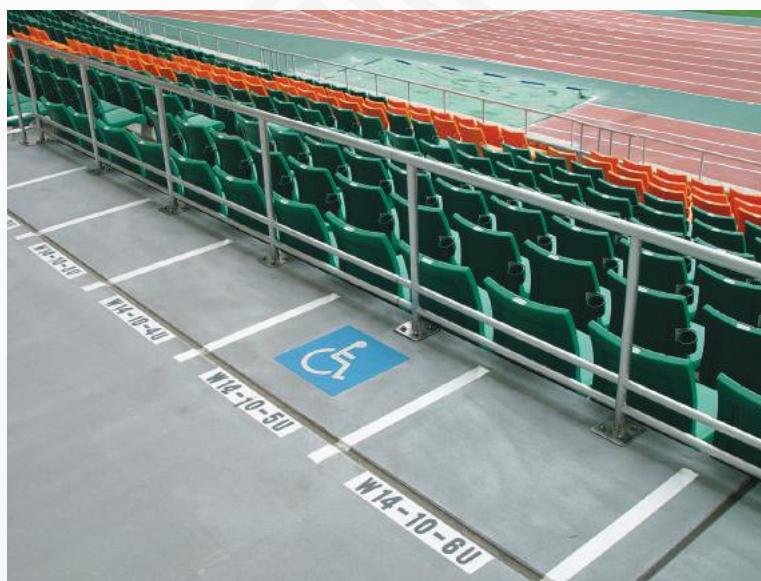

Figure 186: Accessible Spaces

3.3.3.2 Application Guidelines

Where fixed seating is installed, spaces to accommodate mobility devices should be provided. The minimum number of accessible spaces to be provided should comply with Figure 186.

Seating for companions of accessible guests/users should also be provided where accessible viewing spaces are provided. The number of companion seats should be equal to the number of accessible viewing spaces provided. Companion seating should be arranged so that at least one fixed companion seat is provided next to each accessible viewing space. Not less than one percent (1%), but never less than one fixed seat adjacent to access aisles should be a designated aisle seat.



Figure 187: Accessible Viewing Spaces

Number of Fixed Seats in Seating Area	Number of Accessible Viewing Spaces Required
2-100	2
101-200	3
201-300	4
301-400	5
401-500	6
501-900	7
901-1300	8
1301-1700	9
Each 400 seats above 1700	Add 1 accessible space

3.3.3.3 Technical Guidelines

a. Location: All accessible viewing spaces should be served by accessible routes that comply with Section 3.2.2 for interior routes, and 3.1.3 for exterior routes. Routes to accessible viewing spaces and the spaces themselves should not interfere with egress from adjacent rows of seating or aisles. Where the total seating capacity of the building/facility exceeds 100, accessible viewing spaces should be provided in more than one location. At least two accessible viewing spaces should be located side by side.

b. Floor or Ground Surface: The floor or ground surface at accessible viewing spaces should be clear and level and should also comply with Section 3.2.25 for interior ground surfaces, and 3.1.1 for exterior ground surfaces. Locations designated for accessible viewing spaces are permitted to contain removable seating. In locations where the rear of the assembly space or viewing area is at a different elevation to the front of the assembly space or viewing area and the floor is sloped between the front and rear, level floor areas should be provided leading to and at accessible viewing spaces.

c. Width and Length: Where mobility devices are required to enter accessible viewing spaces from the side, the accessible spaces should be a minimum of 900 mm wide and 1500 mm deep. Where mobility devices are required to enter accessible viewing spaces from the front or the rear, the accessible spaces should be not less than 900 mm wide and 1400 mm deep. (Figure 189)



d. Sight Lines behind Seated Spectators: Lines of sight from accessible viewing spaces should be equivalent to lines of sight from fixed seating viewing spaces located in the same row. For example, lines of sight from accessible viewing spaces are permitted to be over the shoulder or between the heads of spectators seated in the row directly in front, provided that this is the same for those people who occupy the fixed seating locations within the same row.

e. Sight Lines behind Standing Spectators: Where there is an expectation or high frequency of spectators standing during events, lines of sight from accessible viewing spaces should be equivalent to lines of sight for someone standing who occupies fixed seating viewing spaces located in the same row. For example, lines of sight from accessible viewing spaces are permitted to be over the shoulder or between the heads of spectators standing in the row directly in front, provided that this is the same for those people occupying fixed seating locations within the same row who are standing. (Figure 188)

f. Companion Seats: Companion seats should be located to provide shoulder alignment with adjacent wheelchair spaces, and should have the floor surface at the same elevation as the floor surface of the accessible viewing space. Companion seat spaces should be equivalent in size, quality, comfort, and amenities to other adjacent fixed seating and is permitted to be movable.

g. Designated Aisle Seats: Designated aisle seats that allow for those who need transfer space should have no armrests on the aisle side, or should include removable or folding armrests on the aisle side. Each of the seats should be clearly identified and signage should be posted at the ticket office location and viewing area entrances to notify patrons of their availability. Clear floor space to accommodate a mobility device should be provided directly adjacent to designated aisle seats.

h. Seat Identification: Each seat should be identified by a sign or marker which provides visual and tactile identification of the seat designation. Signs or markers should contrast (light-on-dark, dark-on-light) and be luminescent. Seats intended for use by people with disabilities should be clearly identified with the International Symbol of Access.

i. Seating Selection: Accessible seating should be available in different areas throughout a facility, and at a variety of price points.

j. Seating Sizes: A variety of seating sizes should be available to accommodate the additional size and weight capacity of people of large stature.

k. Handrails: Where seating is accessed by a ramp or a sloped surface, handrails should be provided on the side of the sloped surface containing no access to seats. Handrails should comply with Section 3.3.13.



3.3.3.4 Illustrations

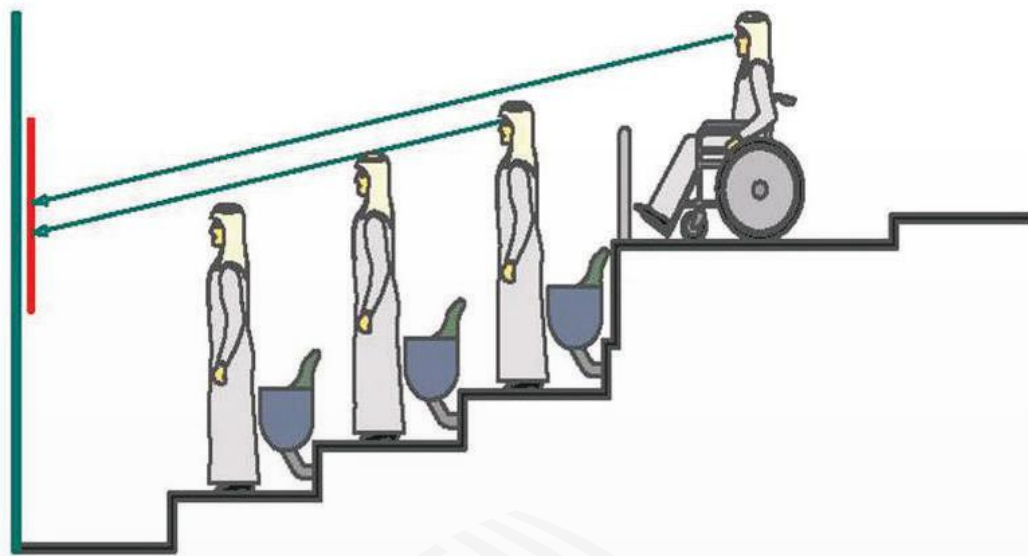

Figure 188: Sight Lines Standing Spectators at Wheelchair Locations

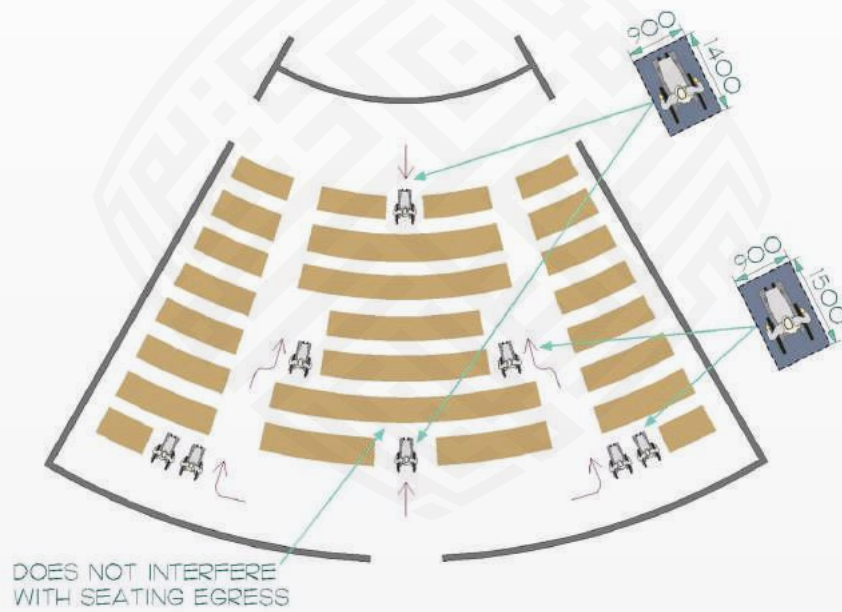

Figure 189: Distribution of Accessible Viewing Spaces

3.3.3.5 Other Considerations

- 2.2 Anthropometric Data
- 3.2.2 Routes, Corridors & Access Aisles
- 3.2.25 Floor Surfaces
- 3.2.26 Overhanging & Protruding Objects
- 3.4.1 Signage

- 3.4.3 Public Address System
- 3.4.7 Assistive Listening Systems
- Appendix B Materials & Finishes
- Appendix B Texture & Color
- Appendix B Acoustics



3.3.4 Raised Platforms and Stages

3.3.4.1 Design Considerations

All raised platform and stage areas should be accessible to people with a varying range of abilities. Performance and backstage areas should provide accessible routes, and safety features should be in place to protect people from falling or from tripping hazards, particularly people with visual impairments.

3.3.4.2 Application Guidelines

All raised platforms, including stages, which are accessible to clients, customers, employees or the general public, should comply with this section.

3.3.4.3 Technical Guidelines

a. Location: Raised platforms should be located on an accessible route that complies with Section 3.2.2 for interior routes, and 3.1.3 for exterior routes.

b. Illumination: Raised platforms should be illuminated to a minimum of 100 lux at floor level.

c. Platform Size: Raised platforms should be allow for the spatial dimensions of wheelchairs and other mobility equipment in compliance with Section 2.2.

d. Detectable Warnings: Raised platforms with un-guarded platform edges should have detectable warning surfaces in compliance with Section 3.4.6.

e. Placement of Detectable Warnings: The placement of detectable warnings should be consistent throughout the setting. At any unprotected platform edge detectable warning surfaces should be positioned parallel to the edge and extend the full length of the platform. Detectable warning surfaces should be positioned 300 mm back from the edge of the raised platform, be 600-900 mm deep and be flush with the adjacent platform surface so as not to create a tripping hazard. (*Figure 190*)



3.3.4.4 Illustrations

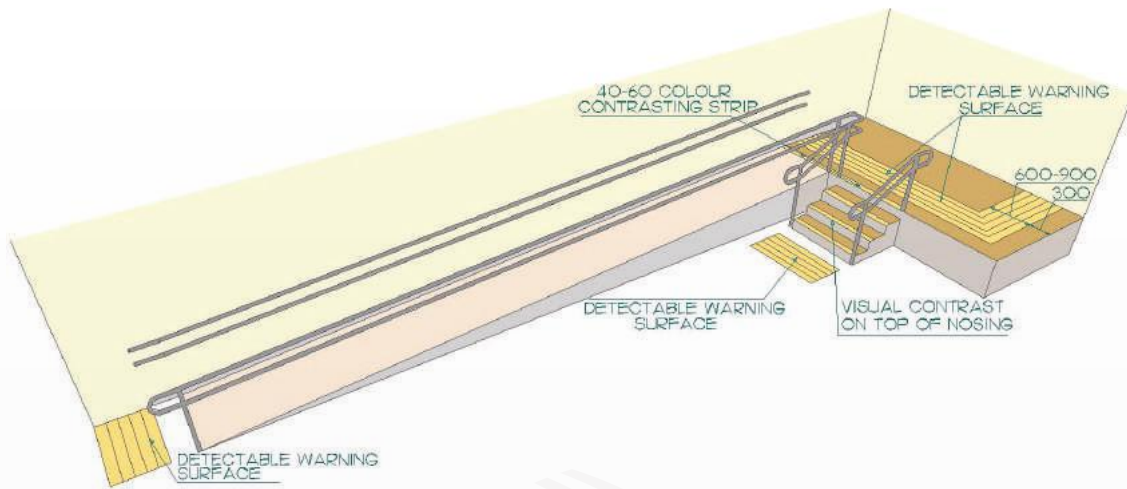

Figure 190: Detectable Warning Surfaces at Raised Platforms

3.3.4.5 Other Considerations

- 2.2 Anthropometric Data
- 3.2.2 Routes, Corridors and Access Aisles
- 3.2.25 Floor Surfaces
- 3.2.26 Overhanging and Protruding Objects
- 3.4.6 Detectable Warning Surfaces

- Appendix B Illumination
- Appendix B Materials and Finishes
- Appendix B Texture and Color



3.3.5 Speaker Podiums & Lecterns

3.3.5.1 Design Considerations

Speaker podiums & lecterns should accommodate the needs of a range of users. Design should allow for seated-use, as well as, standing use. For individuals using wheelchairs, podiums and lecterns need to be low enough to be used and also high enough to provide knee/toe/chair space beneath. The placement of podiums and lecterns should provide sufficient manoeuvring space for a person using a wheelchair or mobility scooter.

3.3.5.2 Application Guidelines

Where speaker podiums & lecterns are provided, at least one speaker podiums or lecterns should comply with this section.

3.3.5.3 Technical Guidelines

a. Location: Speaker podiums and lecterns should be located on an accessible route that complies with Section 3.2.2 for interior routes, and 3.1.3 for exterior routes. Location of speaker podiums and lecterns should allow for a forward approach by people using mobility devices.

b. Clear Floor or Ground Space for Seating: Speaker podiums and lecterns should incorporate a clear floor space of not less than 800 mm wide by 1400 mm deep.

c. Knee and Toe Space: Clear knee and toe spaces should be provided underneath speaker podiums and lecterns that comply with Section 2.2. The knee and toe space depth may overlap the required clear floor space to a maximum of 550 mm.

d. Height: The top surface of speaker podiums and lecterns should be height-adjustable to allow use from a seated or a variety of standing heights.

e. Controls and Operating Mechanisms: Controls and operating mechanisms at speaker podiums and lecterns should comply with Section 3.3.10.

3.3.5.5 Other Considerations

- 2.2 Anthropometric Data
- 3.2.2 Routes, Corridors and Access Aisles
- 3.3.10 Controls and Operating Mechanisms



3.3.6 Tables, Counters and Work Surfaces

3.3.6.1 Design Considerations

The design of tables, counters and work surfaces should reflect the needs of a range of users, in both standing and seated capacities. The height and clearance under tables, counters and work surfaces should provide enough space for the movement of mobility devices. The depth beneath should allow for adequate knee/toe space for people who use a wheelchair. Furniture should be layout to present ample turning and manoeuvring space for a person using a wheelchair or mobility scooter.

3.3.6.2 Application Guidelines

Where fixed or built-in tables, counters and work surfaces are installed in public or common-use staff areas, at least 10%, but not less than one unit should comply with this section.

3.3.6.3 Technical Guidelines

a. Location: Accessible tables, counters and work surfaces located in interior spaces should be on an accessible route that complies with Section 3.2.2 for interior routes, and 3.1.3 for exterior routes.

b. Clear Floor or Ground Space for Seating: A clear floor space should be provided at accessible tables, counters and work surfaces that measures a minimum of 800mm wide and 1400 mm, and allows for a forward approach. (Figure 192)

c. Knee and Toe Space: Knee and toe space should be provided underneath accessible tables, counters and work surfaces, that complies with Section 2.2. Knee and toe space depth is permitted to overlap the required clear floor spaces by a maximum of 550 mm. (Figure 191)

d. Height: The height of the top surfaces of accessible tables, counters and work surfaces should located between 725-850 mm above the floor or ground surface. (Figure 191)

3.3.6.4 Illustrations

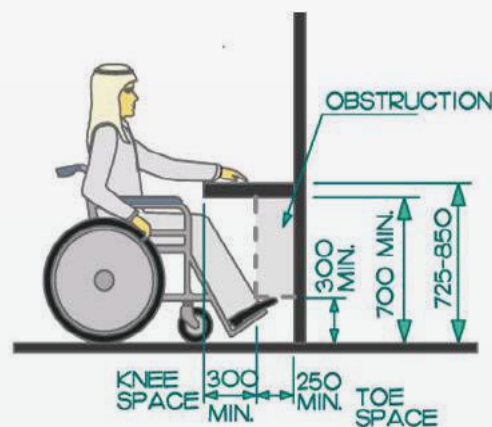

Figure 191: Clearances

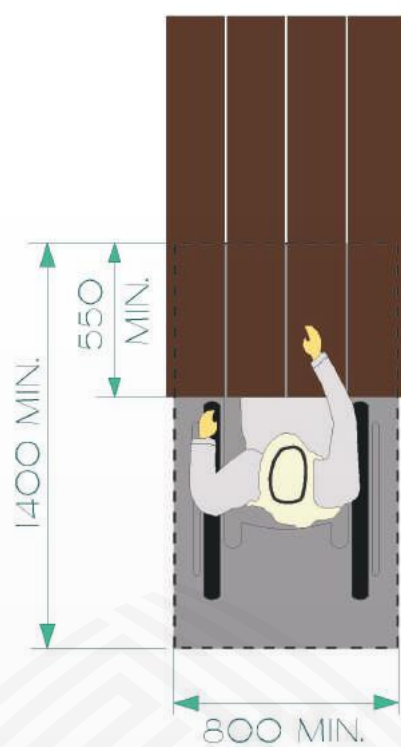

Figure 192: Forward Approach to a Table

3.3.6.5 Other Considerations

- 2.2 Anthropometric Data
- 3.2.2 Routes, Corridors and Access Aisles



3.3.7 Rest Areas and Benches

3.3.7.1 Design Considerations

For those individuals who have difficulty walking or standing for extended periods, a bench and/or rest area is a necessary break from the challenges of travelling. Benches should be located adjacent to pedestrian walkways to ensure convenience without causing an obstruction to the flow of traffic. The height of bench seats should cater to the physical limitations of seniors and people with strength problems, and armrests should be considered to ease the process of sitting and getting up. Benches will be more easily located by a person with a visual impairment if they are adjacent to a landmark, such as a large tree, a bend in a pathway, or a sound source.



Figure 193: Accessible Bench

Bench features armrests, backrest and adjacent space for wheelchair or stroller/pram.

3.3.7.2 Application Guidelines

All benches located in exterior and interior spaces including those located in unpaved areas of parks and beaches should comply with this section.

3.3.7.3 Technical Guidelines

a. Location: Rest areas should be located adjacent to an accessible route complying with Section 3.2.2 for interior routes, and 3.1.3 for exterior routes. The maximum distance between rest areas along an accessible route should be 50 meters.

b. Clear Floor or Ground Space: Rest areas should include a bench or other type of fixed seating. A level, stable and firm ground surface measuring at least 900 mm wide and 1500 mm deep should be provided directly adjacent to one side of the bench. (*Figure 194*)



c. Bench Seating: Benches and other fixed seating should include a seating surface that is a minimum of 1100 mm long and 500-600 mm deep. The seating surface should be located at a height of 450-500 mm above the ground. Arm rests should be provided at each end of the bench. A back support extending the full length of the bench should be provided, begin a maximum 50 mm above the seating surface, and extend upwards for a minimum of 450 mm. (*Figure 195*)

d. Stability: Benches and other fixed seating should be stable and well anchored to the ground surface to prevent movement.

e. Color Contrast: Benches and other fixed seating should be provided in contrasting color to differentiate them from surrounding surfaces.

3.3.7.4 Illustrations

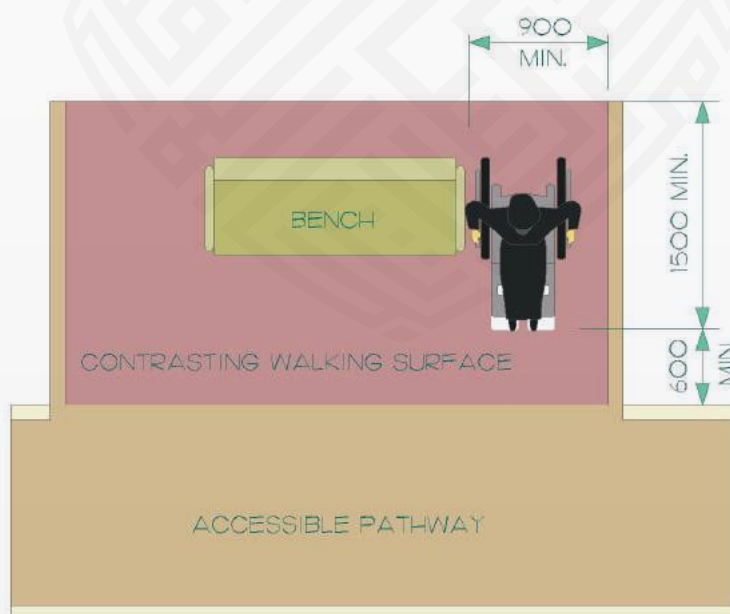

Figure 194: Rest Area



Figure 195: Bench Seating

3.3.7.5 Other Considerations

- 2.2 Anthropometric Data
- 3.1.1 Ground Surfaces
- 3.1.2 Overhead and Protruding Objects
- 3.1.3 Sidewalks, Pavements, Paths and Routes Surfaces

Appendix B Materials and Finishes

Appendix B Texture and Color



3.3.8 Lockers & Baggage Storage

3.3.8.1 Design Considerations

Wherever public or private storage lockers are provided, such as schools, recreational amenities and transit facilities, a percentage of the lockers should be located at a height that allows ease of access to children, people short in stature, or people using a wheelchair or mobility device. The operating mechanisms should be placed in an appropriate position and operable by individuals with limited hand dexterity.

3.3.8.2 Application Guidelines

Lockers or baggage storage units provided in public or common-use areas should comply with this section. Where infeasible to do so, at least 10%, but not less than one unit, should comply.

3.3.8.3 Technical Guidelines

a. Location: Accessible lockers and baggage storage units should be located on accessible routes that comply with Section 3.2.2 for interior routes, and Section 3.1.3 for exterior routes.

b. Clear Floor or Ground Space: A clear floor space measuring a minimum of 1400 mm should be provided in front of lockers, baggage compartments, and carousels to permit forward or side approach by people using mobility devices.

c. Storage Units: Accessible lockers and/or baggage storage units should have no element lower than 450 mm above the floor, and no element higher than 1200 mm above the floor.

d. Operating Controls and Locks: The location of operating controls and locks on accessible lockers and baggage storage units should be a maximum of 1060 mm above the floor and should comply with Section 3.3.10.

e. Identification: Identification used on lockers and baggage storage units should include lettering that is raised or recessed, that is contrasted to the surrounding surfaces and should comply with Section 3.4.1.

f. Baggage Racks or Carousels: Platform surfaces of baggage racks or carousels, such as those used for suitcases, should include a continuous color contrasted strip along its edge and should be located no higher than 450 mm above the floor.



3.3.8.5 Other Considerations

- 2.2 Anthropometric Data
- 3.2.2 Routes, Corridors & Access Aisles
 - 3.2.21 Grab Bar
 - 3.2.25 Floor Surfaces
 - 3.2.26 Overhanging & Protruding Objects
- 3.3.13 Handrails





3.3.9 Storage, Shelving and Display Units

3.3.9.1 Design Considerations

Storage, shelving and display units should be accessible to children, people short in stature, or a person using a wheelchair or mobility scooter. A lower height placement will facilitate object visibility and ease of reach, but may prove problematic to those individuals who have difficulty bending down. For people with a visual impairment, adequate lighting and color contrasts are helpful cues for furniture placements and shelf contents.

3.3.9.2 Application Guidelines

When fixed or built-in storage facilities, such as closets, shelves, cabinets, and drawers are installed, at least one of each should comply with this section.

All shelves or display units used for self-service by customers in mercantile occupancies should comply with this section.

3.3.9.3 Technical Guidelines

a) Location: Storage, shelving and display units should be located on an accessible route that complies with Section 3.2.2 for interior routes, and Section 3.1.3 for exterior routes.

b) Clear Floor or Ground Space: A clear floor space measuring a minimum of 800 x 1400 mm should be provided in front of shelving and display units to allow either forward or side approach by a mobility device.

c) Height: Storage facilities should be designed to accommodate reaches that comply with Section 2.2. The height of accessible clothes rods or shelves should be a maximum of 1350 mm above the floor, where a mobility device is able to pull-up directly adjacent to it. Where a mobility device may only pull-up between 255-535 mm away from the clothes rod or shelf, such as at closets that cannot be entered, the maximum height should be reduced to 1200 mm above the floor.

d) Coat Hooks: Coat hooks, where provided, should be mounted at a maximum height of 1200 mm above the floor. Coat hooks should not be located directly above other objects.

e) Operable Parts, Hardware, and Controls: All hardware used to access storage facilities should comply with Section 3.3.10.



f) Illumination: Storage should be illuminated to at least 100 lux at floor level.

g) Color Contrast: Color contrast should be provided between the wall surfaces, millwork, and operating hardware and controls.

3.3.9.4 Illustrations



Figure 196: Reach Limits for Storage

3.3.9.5 Other Considerations

- 2.2 Anthropometric Data
- 3.2.2 Routes, Corridors and Access Aisles
- 3.3.10 Controls and Operating Mechanisms



3.3.10 Controls and Operating Mechanisms

3.3.10.1 Design Considerations

Controls and operating mechanisms should cater to a diverse range of users. Operating mechanisms that call for a high degree of dexterity or strength will prove troublesome for many individuals, including but not limited to children, individuals with arthritis and people wearing gloves. For those individuals who have difficulties with reach or balance, or those who must use their hands to hold canes or crutches, a mechanism that requires two hands to operate is an unwelcome challenge.

Controls should be placed at a height that acknowledges the lower vantage point of people with wheelchairs or mobility scooters, children, and people of short stature. People with wheelchairs and mobility scooters require additional space in front of operating machines for unobstructed manoeuvrability.

Flush-mounted buttons, touch screens, or controls without tactile markings should be avoided as they are problematic for people with visual impairments. Counterintuitive or graphic controls may be difficult for people with cognitive challenges. The use of contrasting colors will make controls more discernable to all users, especially people with visual impairments.

3.3.10.2 Application Guidelines

Controls and operating mechanisms used by staff or public should comply with this section. Controls to which access and/or use is restricted, and which are not intended for use by general staff or the public, do not need to comply.

3.3.10.3 Technical Guidelines

a. Clear Floor or Ground Surface: Provide a clear floor space measuring a minimum of 800x1400 mm in front of controls and operating mechanisms, to permit a forward or side approach.

b. Operable Portions of Controls and Mechanisms: Operable portions of controls and operating mechanisms should be positioned at a height of 900-1200 mm above the floor (Figure 197). Controls for lifts and power door operators should comply with applicable clauses in Sections 3.2.6, 3.2.1 and 3.2.9.

c. Electrical Outlets and Similar Devices: Electrical receptacles and similar outlets should be mounted at a minimum height of 450 mm above the floor, measured to its centreline. Electrical receptacles built-into systems furniture are not required to



comply with this section provided that outlets complying with this section are located in proximity and are capable of being accessed.

d. Faucets and Other Controls: Faucets and other controls may be manually activated/operated or electronically activated/operated. Where controls and mechanisms are manually activated/operated they should be operable using one hand, without tight grasping, pinching, or twisting of the wrist; and should require a maximum force of 22N to activate/operate.

e. Illumination: Controls and operating mechanisms should be illuminated to a minimum of 100 lux. Where reading is required, illumination of at least 200 lux should be provided.

f. Color Contrast: Controls and operating mechanisms should be color contrasted to the surrounding surfaces and/or environment.

g. Buttons: Where controls contain buttons, the activation surface of the buttons should be raised above surrounding surfaces.

h. Information on or Beside Controls: Where visual information is provided on or beside controls, it should comply with Section 3.4.1. Visual information that is necessary for the proper use of the controls should be also provided in an alternate format such as tactile lettering or auditory information.

i. Intuitive Use: The design, layout and organization of controls and operating mechanisms should be simple and intuitive for the user.

3.3.10.4 Illustrations

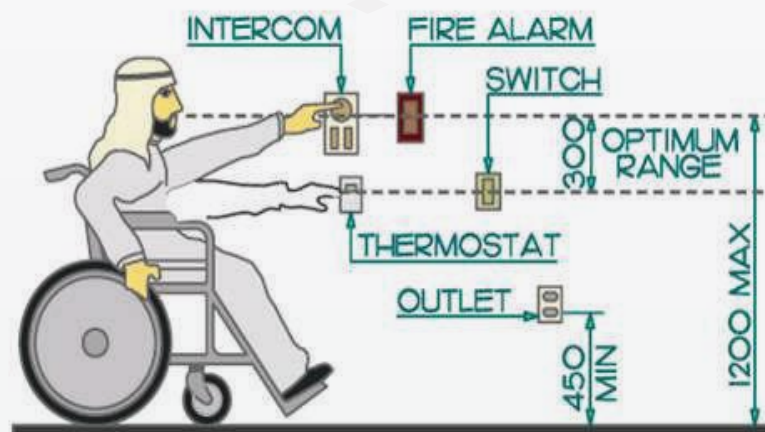

Figure 197: Reach Range for Accessible Controls



3.3.10.5 Other Considerations

- 2.2 Anthropometric Data
- 3.1.2 Overhead and Protruding Objects
- 3.1.12 Street Furniture
- 3.2.2 Routes, Corridors and Access Aisles
- 3.2.6 Lifts
- 3.2.7 Inclined and Vertical Platform Lifts
- 3.2.9 Doors
- 3.2.10 Windows, Glazed Screens and Sidelights
- 3.2.13 Family Toilet Room
- 3.2.14 Toilet Stall
- 3.2.15 Water Closet (WC)
- 3.2.16 Washbasins
- 3.2.17 Urinals
- 3.2.18 Toilet Accessories
- 3.2.19 Bathtubs
- 3.2.20 Showers
- 3.2.22 Offices, Work Areas and Meeting Rooms
- 3.2.24 Dressing Rooms
- 3.2.27 Gates, Turnstiles and Openings
- 3.3.8 Lockers & Baggage Storage
- 3.3.9 Storage, Shelving and Display Units
- 3.3.12 Drinking Fountains
- 3.3.11 Ticketing and Vending Machines
- 3.4.2 Public Telephones
- 3.4.4 Information Systems
- 3.4.5 Card Access, Safety and Security Systems

Appendix B Illumination



3.3.11 Ticketing and Vending Machines

3.3.11.1 Design Considerations

Vending and ticketing machine areas should be designed with consideration to the space that people with wheelchair or mobility aids will require to manoeuvre. Accessible seating areas and/or tables adjacent to vending and ticketing machines offer a convenient respite for those who may have difficulties with long distance travelling or queuing.

The machines should incorporate operating systems that accommodate children, people short in stature, and individuals in wheelchairs or mobility scooters. All mechanisms should be one-hand operable to address the needs of a range of disabilities, such as arthritis, the need to stabilize oneself with a cane, or by a person holding a handful of bags. The inclusion of adequate lighting and contrasting colors will make the vending and ticketing process easier for people with visible impairments.

3.3.11.2 Application Guidelines

Vending and ticketing machines should comply with this section.

3.3.11.3 Technical Guidelines

a. Location: Vending and ticketing machines should be located adjacent to the main path of travel and on accessible routes that comply with Section 3.2.2 for interior routes and Section 3.1.3 for exterior routes.

b. Clear Floor or Ground Surface: A minimum clear, level floor area measuring 800 mm x 1400 mm should be provided at controls and operating mechanisms, to allow a forward or side approach. Clear floor spaces should also comply with Section 2.2.

c. Controls and Operating Mechanisms: Controls and operating mechanisms on vending and ticketing machines, including input and retrieval portions, should comply with Section 3.3.10.

d. Signage: Lettering and characters used on vending and ticketing machines should be at least 13 mm high and use contrasting colors to the surrounding surfaces. Signage used on vending and ticketing machines should also comply with Section 3.4.1.

e) Access from Vehicles: Where vending and ticketing machines are designed to be accessed from within a vehicle, such as at drive-through facilities, they should comply with this section and also reach requirements of Section 2.2.



3.3.11.4 Illustrations

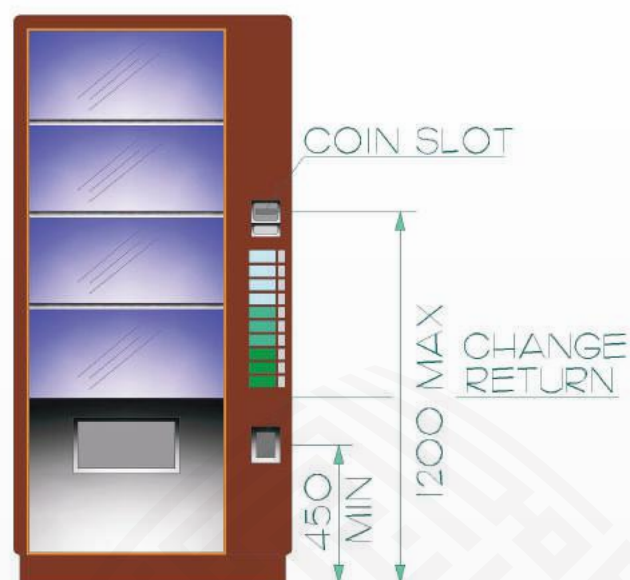

Figure 198: Vending Machine

3.3.11.5 Other Considerations

- 2.2 Anthropometric Data
- 3.2.2 Routes, Corridors and Access Aisles
- 3.3.10 Controls and Operating Mechanisms

Appendix B Texture and Color



3.3.12 Drinking Fountains

3.3.12.1 Design Considerations

Drinking fountains should be designed in respect to the lower reach limitations of children, people small in stature and people who are using a wheelchair or mobility scooter to access the controls and the water. Of equal importance are those individuals who have difficulty bending over and require a taller design.

The operating system should also incorporate features that accommodate people with limited hand strength or dexterity, and all fountain components should be marked with contrasting colors to aid those individuals with visual impairments. Drinking fountains should be placed away from the path of travel, recessed, and mounted at a height that is detectable to a person who is using a long white cane. For people using a wheelchair or mobility scooter, angled recessed alcove designs expand the available space for movement.



Figure 199: Drinking Fountains

Showing dual-height accessible drinking fountains, each set at a different height to allow for taller or shorter or seated users.



3.3.12.2 Application Guidelines

All drinking fountains should comply with this section.

3.3.12.3 Technical Guidelines

a. Location: Drinking fountains should be located on accessible routes that meet the requirements of Section 3.2.2 for interior routes and Section 3.1.3 for exterior routes. Drinking fountains should be recessed out of the primary path of travel. *(Figure 201)*

b. Spout Outlet Height: Drinking fountains should provide two spout outlets, one located 750 mm above the floor and the other located 1000-1100 mm above the floor. Alternatively, separate fountains placed in the same location to each other are permitted to be provided at two heights. *(Figure 200)*

c. Spout Location: Drinking fountain spouts should be located at a minimum of 380 mm from the rear of the unit and no more than 125 mm from the front edge of the unit.

d. Water Flow: Water flowing out of the spout should project above the spout a minimum of 100 mm and in a direction that is parallel to, or near parallel to, the front face of the drinking fountain unit.

e. Clear Floor Space: Clear floor space should be provided that allows a forward approach to the lower spout and complies with Section 2.2, . Knee and toe space should also be provided below the fountain complying with Section 2.2. All clear spaces should be centred to the spout. *(Figure 201)*

f. Operable Parts: Operable parts of all drinking fountains should comply with Section 3.3.10.

g. Color Contrast: Drinking fountains should be color-contrasted with the background environment. Operable parts of drinking fountains should be color contrasted from the surface on which they are located.



3.3.12.4 Illustrations

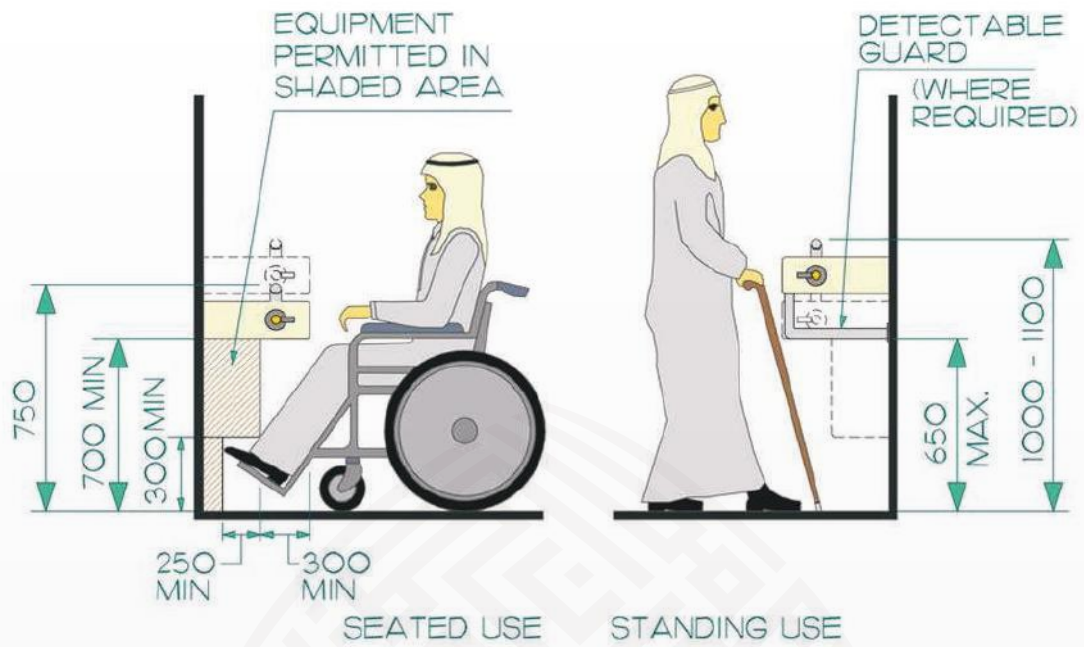

Figure 200: Fountain Dimensions

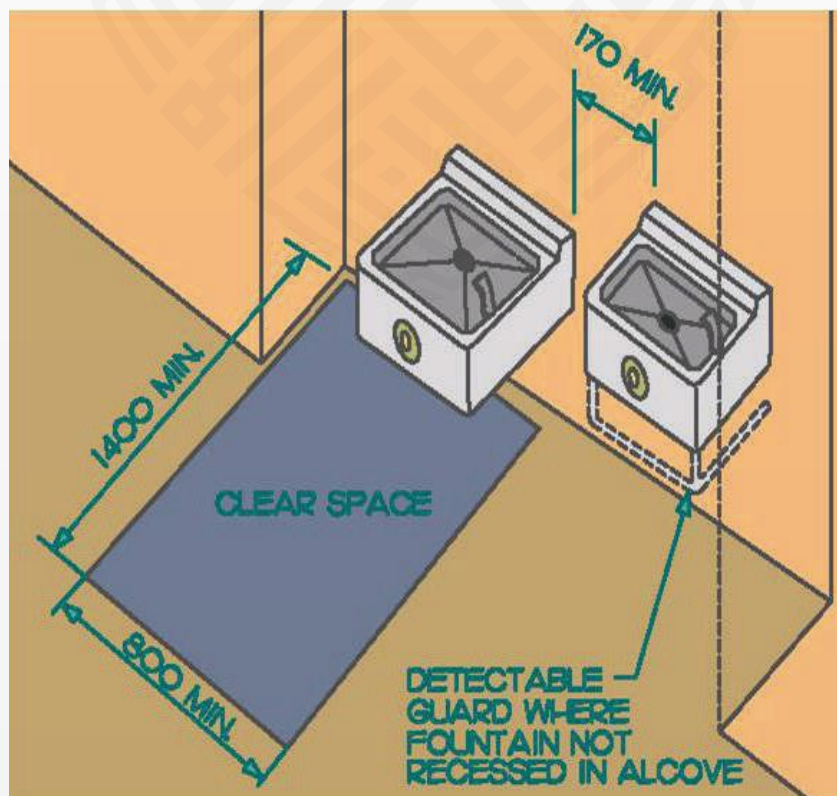

Figure 201: Alcove Configuration



3.3.12.5 Other Considerations

- 2.2 Anthropometric Data
- 3.1.1 Ground Surfaces
- 3.1.2 Overhead and Protruding Objects
- 3.1.3 Sidewalks, Pavements, Paths and Routes
- 3.2.2 Routes, Corridors and Access Aisles
- 3.2.25 Floor Surfaces
- 3.2.26 Overhanging and Protruding Objects

Appendix B Illumination

Appendix B Materials and Finishes

Appendix B Texture and Color

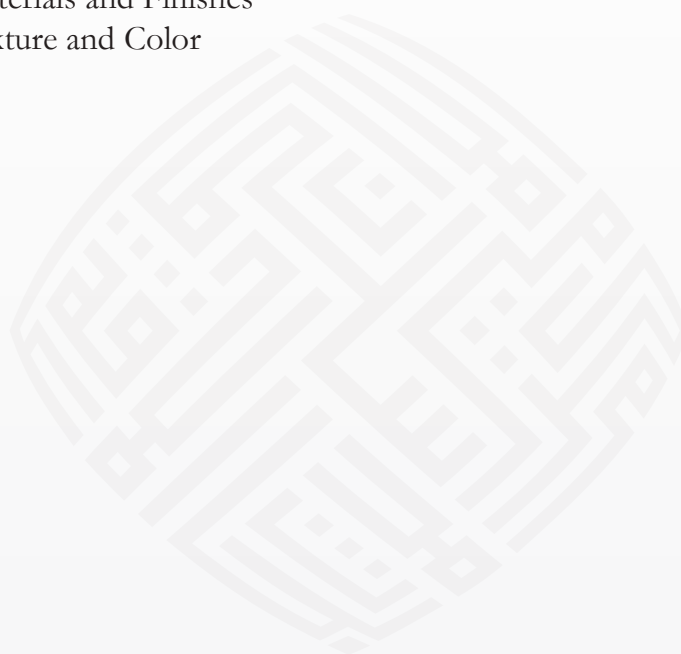



3.3.13 Handrails

3.3.13.1 Design Considerations

Handrails should be designed in a way that reflects the size and abilities of all users. The circumference of a bar should be able to accommodate an adult or child's grip, as well as, people with arthritis. Whenever possible, handrails should also be positioned at two different heights to provide security to tall people and people short in stature.

For people with a visual impairment, contrasting colors and the extension of handrails at the top and bottom of stairs provide important navigational cues. Handrails should be placed before and after a set of stairs to provide a safe and stable gait for an individual has difficulty ascending or descending a staircase. The installation of handrails should be continuous and free from interruptions to prevent destabilising breaks in an individual's handhold.

The clear space between the wall and a handrail should be sized to allow knuckles and hands to pass but not an arm if an individual slips during a fall or stumbles on a set of stairs or a ramp.



Figure 202: Handrail Extensions

Showing an example of a stair featuring color-contrasted handrail extensions.



Figure 203: Dual Height Handrails

Showing an example of a ramp featuring dual height handrails.

3.3.13.2 Application Guidelines

All handrails should comply with this section.



3.3.13.3 Technical Guidelines

a. Mounting Height: Handrails should be provided at two heights with the upper handrail located between 875-925 mm above the floor, measured to the top of the handrail. The lower handrail should be located between 650-750 mm above the floor, measured to the top of the handrail. The height of handrails mounted at stairs is measured vertically from a line drawn through the outer edges of the stair nosing.

b. Grip: Handrails should have a diameter of 30-40 mm. Non-circular handrail shapes do not allow the thumb and fingers to lock and therefore are not as effective for grasping so are not recommended. All handrails should be slip resistant, free from sharp or abrasive elements and installed continuously, without interruption that can break a handhold such as by newel posts, other construction elements, or obstructions. A clear space should always be provided between the wall and the handrail, with a minimum width of 50 mm at a smooth wall and 60 mm at rough wall surface. When a handrail is recessed, a clear space should be provided a minimum of 450 mm above the top of the handrail and 35-45 mm below the bottom of the handrail.

c. Termination: Required extensions on handrails at stairs and ramps should return to the wall, floor or a post to avoid catching clothes or becoming a hazard. A tactile indicator in the form of a domed button should be provided on the top surface of the handrail and should be located 140-160 mm from the broken end of the handrail in locations where a handrail is broken, i.e. not returned to a wall, floor or post.

d. Load Values: Handrails and their supports should have the capacity to withstand force of at least 1.3 kN applied in any direction.

e. Color Contrast: Handrails should incorporate a pronounced color contrast, to differentiate them from the surrounding environment.

f. Hazardous Areas: Handrails that lead to hazardous areas should be equipped with detectable cues, for example: a roughened handrail surface will alert people with visual impairments. The detectable warning surface on handrails should be a minimum of 1200 mm long and be located before the potential hazard.

g. Emergency Exiting: There should be a color contrasting tactile strip applied to the top and bottom edges of the handrail where the handrail is located along emergency exit routes on stairs, ramps, or other installations.



3.3.13.4 Illustrations

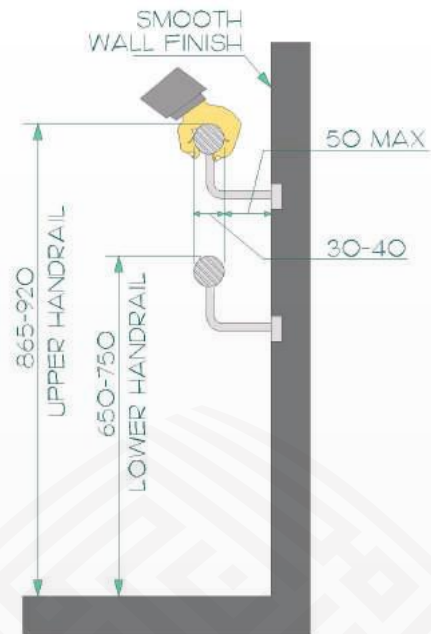

Figure 204: Handrail

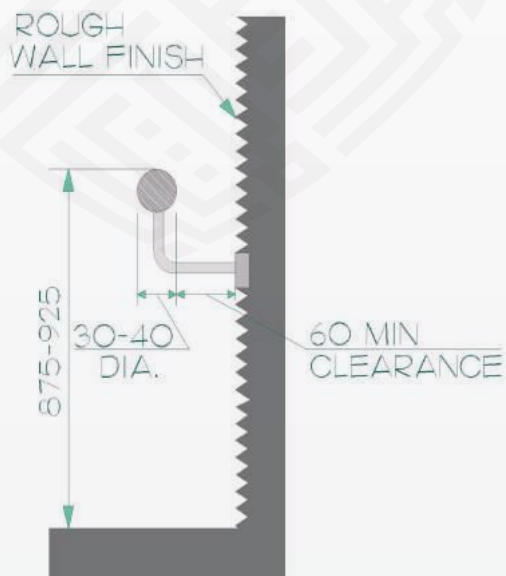

Figure 205: Handrail at Rough Wall

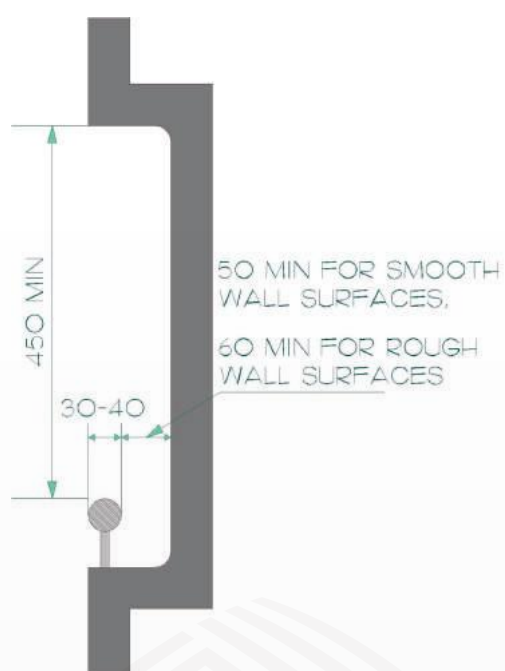
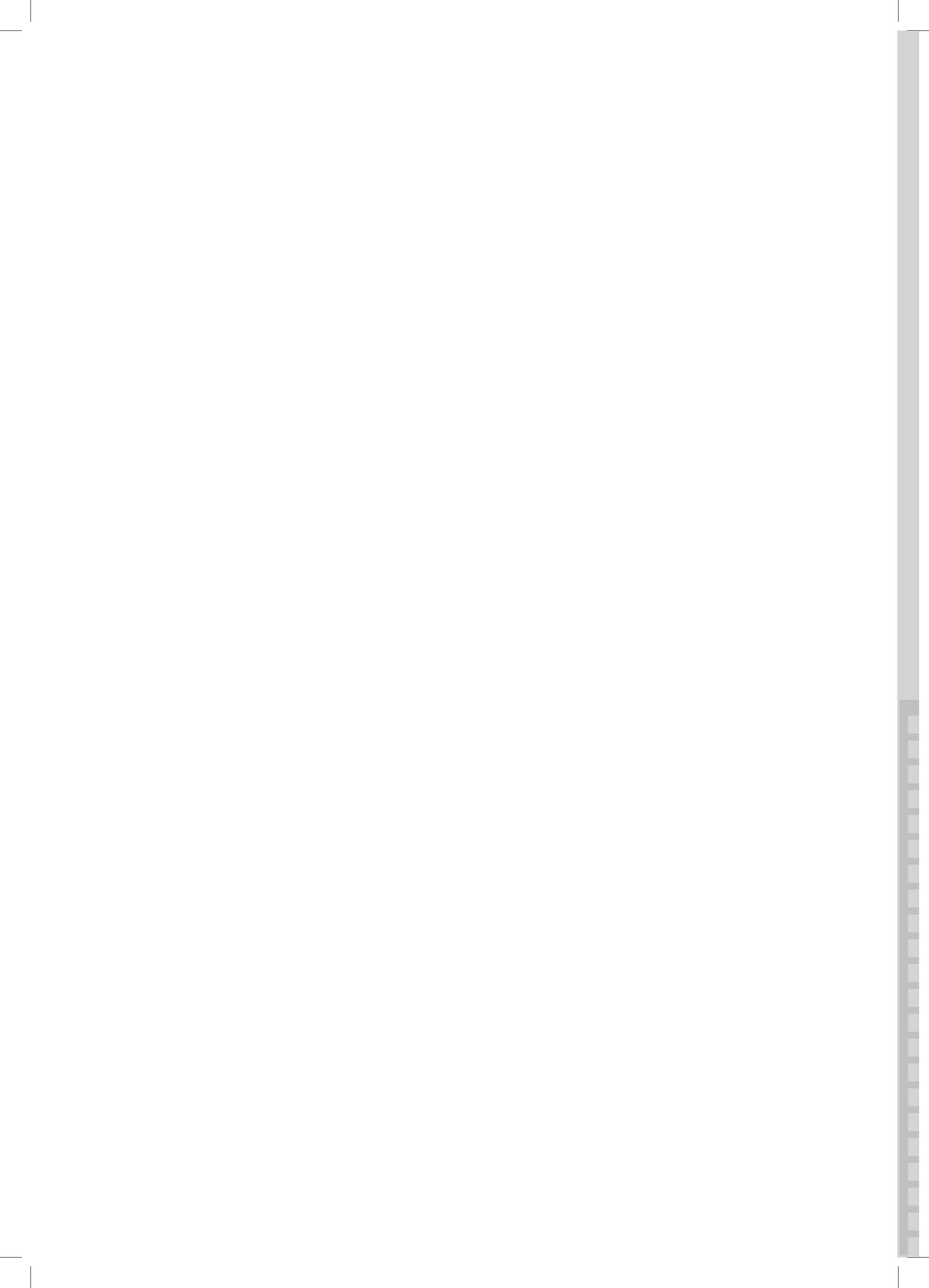

Figure 206: Handrail in Recess

3.3.13.5 Other Considerations

- 2.2 Anthropometric Data
- 3.1.4 Exterior Ramps
- 3.1.5 Exterior Stairs
- 3.2.3 Interior Ramps
- 3.2.4 Interior Stairs
- 3.2.24 Dressing Rooms

Appendix B Texture and Color



UABE TECHNICAL & DESIGN GUIDELINES

3.4 Communication and Safety Systems





3.4 COMMUNICATION and SAFETY SYSTEMS

3.4.1 Signage

3.4.1.1 Design Considerations

All public spaces require simple, uncluttered and understandable signage. Signage should include graphics whenever possible to help children, those with a limited literacy level and those who speak a different language. The use of contrasting colors and raised tactile lettering will increase readability and aid those with a visual impairment. All users benefit from clear objectives, plain language and visual cues. When symbols are used, the intent should be evident, intuitive and culturally universal.

3.4.1.2 Application Guidelines

All signage should comply with this section.

Signs that indicate permanent rooms or spaces should be wall-mounted and incorporate tactile characters and numbers. Tactile markings should also accompany the text of:

- regulatory signs, such as prohibition and mandatory signs;
- warning signs, such as caution and danger signs; and
- identification signs, such as rooms, titles, names, or numbers.

Directional or informational signs pertaining to functional spaces should comply with this section. Exception: Facility directories and other signs that are temporary are not required to comply.

Menus in eating establishments should be available in alternative formats, including Braille and large text.

Elements and spaces of accessible facilities that should be identified using the International Symbol of Accessibility are:

- parking spaces, designated as reserved for individuals with disabilities;
- accessible passenger loading zones;
- accessible ramps located in a barrier-free path of travel serving a building entrance;
- accessible entrances when not all are accessible (inaccessible entrances should have directional signage to indicate the route to the nearest accessible entrance);
- accessible toilet and bathing facilities, including single-use portable units, when not all are accessible;
- accessible telephones;
- accessible lifts and other elevating devices;
- accessible means of egress; and
- areas of rescue assistance.



3.4.1.3 Technical Guidelines

a. Location – Rooms and Spaces: Permanent identification signs should be installed on the wall, adjacent to the latch side of the door entering rooms and spaces. Room identification signs should be positioned within 150 mm of the door jamb, with the centreline located 1400 mm above the floor. Where there is no available wall space adjacent to the latch side of the door, signs should be placed on the nearest adjacent wall. Signage should be consistently located throughout the facility.

b. Location – Stairways: Within enclosed stairways, tactile numbers indicating the floor level should be located on the latch side of the entry/exit door at each floor level. Tactile floor level numbers should be positioned on the wall within 150 mm of the door jamb and located at a consistent height between 1350-1500 mm above the floor.

c. Location – Decision Making Points: Signs should be located at all decision making points along an accessible route, such as at intersections of routes, stairways, lifts and escalators.

d. Overhead Signage: Overhead signage should not create a hazard and should comply with Section 3.2.26 where located on the interior and Section 3.1.2 on the exterior. Overhead signage should be duplicated and provided on walls adjacent to the overhead signage. Overhead signage located behind counters should be duplicated in a location that provides clear space for an approach that complies with Section 2.2 and positioned with the centreline located at 1400 mm above the floor. Overhead signage should offer sight lines from a seated or standing position.

e. Case and Style: Alphanumeric characters used on signs should use Arabic numerals and a sans serif typeface, such as Arial or Helvetica.

f. Character Proportions: Characters used on signs should have a width-to-height ratio between 3:5 and 1:1 and have a stroke-width-to-height ratio between 1:5 and 1:10.

g. Character Height: Minimum character heights are based on the maximum distance they are intended to be viewed from. (*Figure 207*)

h. Finish and Contrast: An eggshell, matte or other glare-free finish should be used on sign characters, symbols and backgrounds. Signage should be marked with contrasting colors, and text should be either light characters on a dark background or dark characters on a light background. (*Figure 208*)

i. Tactile Raised Characters: Where signs are required to be tactile, characters should be raised a minimum of 0.8 mm above the sign background surface. Raised characters should not contain sharply finished edges. Tactile characters should measure between 16-50 mm high, be a sans serif typeface and should include un-contracted Braille (*Figure 210*).



Figure 207: Minimum Character Height based on Viewing Distance

Maximum viewing distance (mm)	Minimum character height (mm)
6000	200
3600	150
2500	100
2300	75
1500	50
750	25

j. Clear Floor and Ground Surface: A tactile sign should allow a person to approach the sign within 100 mm without encountering protruding objects or having to stand within a door swing.

k. Pictograms: Pictograms should be supplemented with equivalent visual and tactile characters positioned directly below the pictogram. Pictograms should measure a minimum of 150 mm high. A clear wall space measuring at least 75 mm should be provided around all sides of tactile signage.

l. Illumination: All signs should be illuminated to a minimum of 200 lux.

m. Audible Signage: Audible signs (infrared and digital) that are readable by people with a visual impairment using a receiving device can provide an orientation aid. Audible signs should duplicate information seen visually into spoken form including, but not limited to, street and building signs, visual pedestrian traffic signals, and for interior way-finding and information systems.

n. Directories: Directories and other informational systems should be mounted vertically or horizontally raised at an angle. Directories should be approachable and reachable from both a standing and seated position. Manoeuvring and clear space should be provided in front of directories that comply with Section 2.2.

o. Comprehensibility: The use of visual symbols is preferred to written language, to eliminate confusion for people with language and/or reading barriers. Color coding can strengthen messages when used as a coherent and consistent system throughout a facility.

p. Directional Signage: Directional signs should use plain language, be concise with as few instructions as possible. Directional symbols, such as arrows, should be clear, sharp, and not highly stylized.



3.4.1.4 Illustrations



Figure 208: Color Contrast on Signs



Figure 209: Examples of Pictograms (Refer to Appendix C for further information on International Access Symbols for Pictograms)



Figure 210: Tactile Lettering



Figure 211: International Symbol of Access



Figure 212: Pictogram for Limited Mobility Parking Space

3.4.1.5 Other Considerations

- 3.1.2 Overhead and Protruding Objects
- 3.1.3 Sidewalks, Pavements, Paths and Routes
- 3.1.9 Vehicle Parking
- 3.1.10 Passenger-Loading Zones
- 3.1.4 Ramps
- 3.2.1 Entrances
- 3.2.6 Lifts
- 3.2.7 Inclined and Vertical Platform Lifts
- 3.2.9 Doors
- 3.2.11 Toilet Facilities
- 3.2.13 Family Toilet Room
- 3.2.24 Dressing Rooms
- 3.2.27 Gates, Turnstiles and Opening
- 3.4.2 Public Telephones
- 3.4.9 Emergency Exits, Areas of Rescue Assistance and Fire Evacuation

Appendix B Illumination

Appendix B Texture and Color



3.4.2 Public Telephones

3.4.2.1 Design Considerations

The height of public telephones should also account for the physical limitations of children, people short in stature, or people in a seated position. A longer cord is required to aid those who may be unable to reach the phone due to a mobility device and the inclusion of a fold-down seat provides a respite for those who may have difficulty standing for extended periods. For those who are hard of hearing, adjustable volume controls and/or the addition of a shelf to support a text telephone (TTY) device are important for equitable use. If the telephone is projecting from a wall, the sides should be long white cane detectable to prevent injury to those with visual impairments.

3.4.2.2 Application Guidelines

Public pay phones, public closed-circuit phones and other public telephones, shall comply with this Section.

The number of accessible telephone units to be provided should comply with Figure 213.

Figure 213: Number of Accessible Telephones Required

Number of each type of telephone provided on each floor	Number of telephones required to comply with this section
1 or more single unit	1 per floor
1 bank	1 per floor
2 or more banks	1 per bank An accessible unit may be installed as a single unit in proximity to (either visible or with signage) the bank. At least one public telephone per floor should meet the requirements for a forward reach telephone.

Note: A bank of telephones consists of two or more adjacent public telephones, often installed as a unit.



Volume controls shall be provided for all accessible telephones. Additionally, 25%, but never less than one, of all other public telephones, including closed-circuit telephones, shall be equipped with volume controls. They should be distributed evenly throughout the facility.

Accessible telephones should be identified with signage complying with Section 3.4.1. Where public pay telephones are provided as multiple units, at least one phone should be configured for seated use and at least one phone for standing use.

At least one interior public text telephone (TTY) should be provided where an interior public pay telephone is provided in a public use area.

At least one public text telephone should be provided in a secured area where an interior public pay telephone is provided in the secured area of a detention or correctional facility subject to 3.5.7. Areas used only by detainees, inmates, and security personnel are secured areas.

3.4.2.3 Technical Guidelines

a. Location: Accessible telephones should be located on accessible routes that comply with Section 3.2.2 for interior routes and Section 3.1.3 for exterior routes. Telephones, enclosures and related equipment should be recessed into alcoves located adjacent to the main path of travel. Telephones should be located away from noisy locations which could interfere with a user's ability to hear.

b. Protruding and Overhead Objects: Where telephones, enclosures and related equipment are not located in recessed locations, they should be cane detectable and comply with Section 3.1.2 on exterior routes and Section 3.2.26 for interior routes.

c. Clear Floor or Ground Surface: Clear floor space measuring a minimum of 800 mm wide by 1400 mm deep should be provided in front of telephones to allow a forward or side approach. Knee and toe spaces beneath the telephone should be provided that comply with Section 2.2. Where a clear height of 700 mm is provided for knee space, the clear floor or ground space may extend a maximum of 480 mm beneath the telephone.

d. Operating Controls: Accessible telephones provided for people using a mobility device should have operable portions mounted at a maximum height of 1200 mm above the floor. Reach ranges for operable portions should also comply with Section 2.2. (Figure 214)

e. Push Button Controls: When available, push-button controls should be provided on accessible telephones.



f. Push Button Characters: When push button characters are provided they should contrast with the button background and with the surface they are mounted on. All surfaces should be non-glare (matte finish) on.

g. Cord Length: Telephones should be designed with a handset cord length of at least 1000 mm.

h. Illumination: Operating mechanisms, the directory, and shelf of accessible telephones should be illuminated at a minimum 200 lux.

i. Shelf: A level telephone directory shelf should be provided at telephones measuring at least 500 mm wide and 350 mm deep. *(Figure 214)*

j. Volume Control: Telephone receivers should include graduated volume controls.

k. Flux Coil Compatibility: In order for telephones to be hearing aid compatible, they should have a flux coil in the receiver.

l. TTY (Text Telephones): When text telephones (TTY's) are used with a pay telephone, the device should be permanently affixed within, or adjacent to, the telephone enclosure. The telephone cord of pay telephones should be sufficiently long to allow connection between the text telephone (TTY) and the telephone receiver if an acoustic coupler is used. Where telephones are for use by people who are deaf, deafened, hard of hearing, or speech-impaired, a separate additional telephone should be from those provided for people who use wheelchairs or mobility scooters.

m. TTY Shelf: A shelf installed to accommodate the use of a TTY should be at least 250 mm wide and 350 mm deep, with at least 250 mm clear space above the shelf. The shelf should be equipped with an electrical outlet, within or adjacent to the telephone enclosure, and be equipped with a handset capable of being placed flush on the surface of the shelf. *(Figure 214)*

n. Signage: Accessible telephones should be identified using the appropriate pictogram symbol of accessibility for hearing impaired, heard of hearing, mobility impaired, and the symbol for teletypewriter (TTY); refer to Section 3.4.1. *(Figure 214)*



3.4.2.4 Illustrations

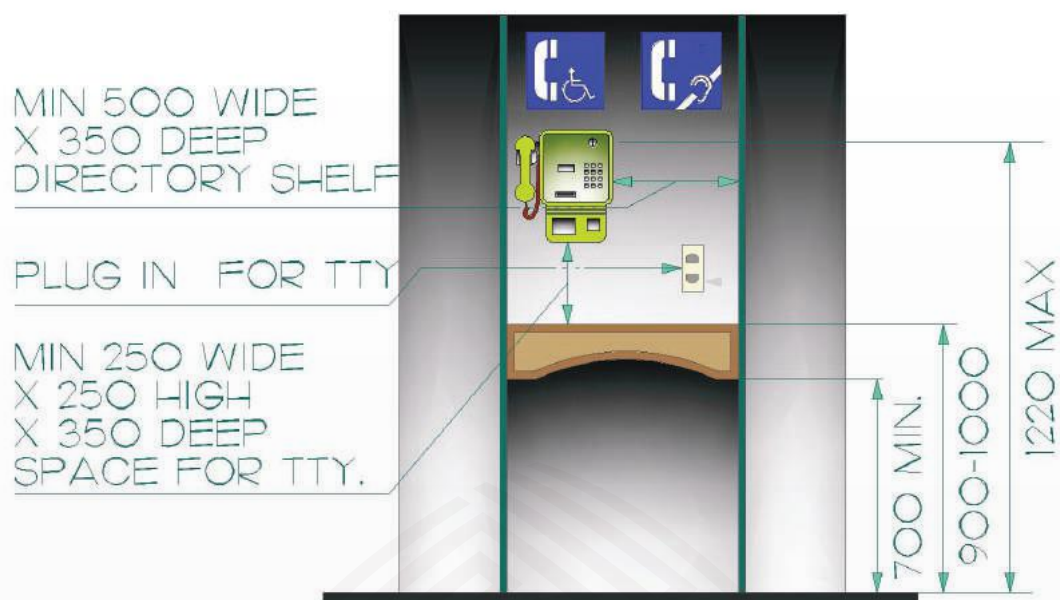

Figure 214: Accessible Telephones

3.4.2.5 Other Considerations

- 2.2 Anthropometric Data
- 3.2.2 Routes, Corridors and Access Aisles
- 3.2.26 Overhead and Protruding Objects
- 3.3.10 Controls and Operating Mechanisms
- 3.4.1 Signage

Appendix B Illumination
pendix B Texture and Color



3.4.3 Public Address Systems

3.4.3.1 Design Considerations

Public address systems are vital communication aids and they should also be designed with those who are hard of hearing. Background noise should be minimised as much as possible, and all distortion and/or feedback eliminated. It should be easy to hear projected messages above the ambient noise in a public environment. For those individuals who cannot hear an audible public address system, visual equivalents should also be present.

3.4.3.2 Application Guidelines

Public address systems should comply with this section.

3.4.3.3 Technical Guidelines

a. Location: Public address speakers should be positioned ceiling or wall mounted overhead and comply with Section 3.1.2 for exterior locations and 3.2.26 for interior locations. Public address systems should provide sound coverage in required areas, such as corridors, meeting rooms and assembly areas, recreational and entertainment facilities, educational facilities, and common use areas in institutional settings.

b. Zoning: Public address systems should be located so that background noise is minimised and information may be only broadcast to key locations.

c. Music: Music should not be transmitted continuously or throughout an entire facility where public address systems are used for background music.

d. All-Point Call Systems: All-point call systems should be restricted to fire and emergency information.

e. Paging Systems: Paging systems for staff and other key people should be unobtrusive and of low volume, and broadcast only at those devices or locations where such people are likely to be located.

f. Visual Systems: Audible public address systems should be supplemented with visual equivalents.

3.4.3.5 Other Considerations

3.4.9 Emergency Exits, Areas of Rescue Assistance and Fire Evacuation
Appendix B Acoustics



3.4.4

Information Systems

3.4.4.1 Design Considerations

All facility users should have equal access to information. Alternatives should be present where universally accessible formats are not possible; for example, an audio interface can be installed alongside video display terminals as an alternative for people with a visual impairment.

Information terminals should be designed with the needs of those people with wheelchairs or mobility scooters in mind, specifically an altered vantage point and varied reach ranges.

3.4.4.2 Application Guidelines

Information systems, such as display kiosks and video display terminals, should comply with this section.

3.4.4.3 Technical Guidelines

a. Video Display Terminals: Where information is provided to customers, clients, or the general public by video display terminals, the same information should be available in an alternative format, such as large-text print, audio, or Braille. Large-text print should use at least 16 point font size.

b. Interactive Terminals: Interactive information systems, such as touch-screen video display, keyboard or keypad access, in facilities used by the general public should be positioned at a height that accommodates use by a person in a seated or standing position and comply with Section 2.2.

c. Controls and Operating Mechanisms: Buttons that provide access to public information system, such as push buttons, should comply with Section 3.3.10. Buttons should be identifiable by color and/or tone from the background color, and should include raised numbers, numerals or symbols that comply with Section 3.4.1.

d. Layout: Labels and descriptive information should be inclined from the horizontal and at a height above the floor for easy access by a seated or standing person and comply with Section 2.2.

e. Alternative Formats: Essential print information should be conveyed with large text on a highly contrasting background color, as well as, in alternative formats, such as audiotape and large-text print.

3.4.4.5 Other Considerations

3.3.10 Controls & Operating Mechanisms

Appendix B Texture & Color



3.4.5 Card Access, Safety and Security Systems

3.4.5.1 Design Considerations

Security is an important issue for all facility users, but for those people who may feel that they have a higher degree of vulnerability, such as some seniors and people with disabilities, additional assurance is required.

Security can be promoted by adequate lighting and accessible signalling devices. In individual washrooms, an emergency signalling device should be in place to facilitate a call for help in the case of an unsupervised fall or injury.

Card-access systems should be designed to be operated by people with varying abilities, including people with reduced manual dexterity, poor vision, or difficulty with reaching. Heat-sensing activation buttons should not be used as they are indiscernible to a person who is blind.

3.4.5.2 Application Guidelines

Card-access, safety, and security systems should comply with this section.

3.4.5.3 Technical Guidelines

a. Height and Mounting Location: Security system devices should be located adjacent to the door they serve, and should be out of the way of the door swing. They should be wall-mounted and positioned 900 - 1000 mm above the floor or ground. Clear space in compliance with Section 2.2 should be provided at interactive access, security and safety devices.

b. Contrast: Contrasting colors should be used to differentiate security system devices from the surrounding surface.

c. Signalling: Visible signals and audible tones should be incorporated into security systems that use signals to provide information to users.

d. Card Entry Systems: The use of proximity reader systems that require cards only to be positioned in close proximity to the activation device are desired over the use of devices requiring insertion of the card into/through the device. Where card-slot systems are used, the card slot should be illuminated or color contrasted from the mounting plate and it should have a bevelled edge to guide the card into the slot. Card-slot entry systems should also include a tactile graphic symbol that surrounds the surface that describes the cards purpose and its orientation for insertion. Cards used for entry systems should use distinctive color, texture, or raised graphic/lettering on one side.



e. Keypad/Encoded Systems: Encoded-entry/exit systems, such as keypads, should incorporate raised buttons that include raised numerals or letters that comply with Section 3.4.1.

g. Intercom Entry Systems: Intercom entry systems should include both audible and visual features to both provide access as well as to indicate that access has been granted.

h. Illumination: Illumination levels at card access, security system and safety devices should be a minimum of 200 lux.

i. Telephones: An accessible public telephone should be located in close proximity where card access, security system, and safety devices are installed.

3.4.5.5 Other Considerations

- 2.2 Anthropometric Data
- 3.1.3 Sidewalks, Pavements, Paths and Routes
- 3.1.10 Passenger Drop-off Areas
- 3.2.1 Entrances
- 3.2.6 Lifts
- 3.2.7 Inclined and Vertical Platform Lifts
- 3.2.9 Doors
- 3.2.13 Family Toilet Room
- 3.2.22 Offices, Work Areas and Meeting Rooms
- 3.3.10 Controls and Operating Mechanisms

Appendix B Texture and Color



3.4.6 Detectable Warning Systems

3.4.6.1 Design Considerations

Detectable warning surfaces are integral to the safety and personal freedom of those with visual impairments. A change in texture or color will alert all pedestrians to potential hazards, such as crosswalks, stairs or hazardous drop off edges at raised platform locations. The placement of detectable warning surfaces should be consistent throughout a facility, and the transition zone between two surfaces should not constitute a tripping hazard.



Figure 215: Detectable Warning Surface at Kerb cut



Figure 216: Detectable Warning Surface at Top of Stair

3.4.6.2 Application Guidelines

All detectable warning surfaces should comply with this section.



3.4.6.3 Technical Guidelines

a. Contrast: Contrasting colors should be used to differentiate detectable warning surfaces from adjacent surfaces, either light on dark or dark on light.

b. Texture: Detectable warning surfaces should be slip-resistant.

c. Dome Size: Detectable warning surfaces should include truncated domes that project a height of 4.5-5.5 mm above the base surface. Truncated domes used on detectable warning surfaces should have a base diameter of 21-25 mm (*Figure 218*).

d. Dome Spacing: Truncated domes used on detectable warning surfaces should be organized in a regular pattern that has spacing of 55-65 mm, measured from centre to centre of the domes (*Figure 218*).

3.4.6.4 Illustrations

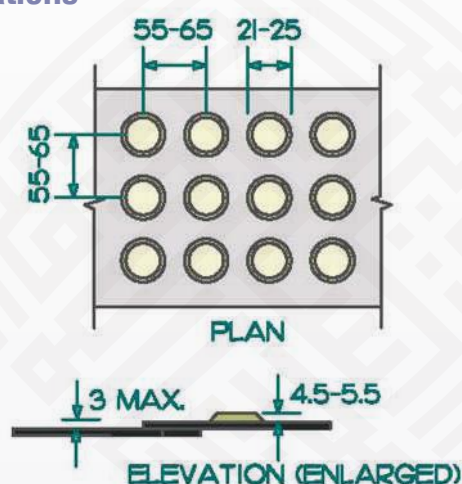

Figure 218: Truncated Dome Detectable Warning Surface

3.4.6.5 Other Considerations

- | | |
|--|---|
| 3.1.2 Overhead and Protruding Objects | 3.2.26 Overhanging & Protruding Objects |
| 3.1.3 Sidewalks, Pavements, Paths & Routes | 3.3.4 Raised Platforms & Stage |
| 3.1.4 Exterior Ramps | 3.3.12 Drinking Fountains |
| 3.1.5 Exterior Stairs | 3.3.13 Handrails |
| 3.1.6 Kerb Cuts | |
| 3.1.9 Vehicle Parking | |
| 3.1.10 Passenger Drop-off Areas | Appendix B Texture & Color |
| 3.2.3 Interior Ramps | |
| 3.2.4 Interior Stairs | |
| 3.2.5 Escalators | |
| 3.2.8 Moving Walks | |



3.4.7 Assistive Listening Systems

3.4.7.1 Design Considerations

Assistive listening devices should be provided for those people who have difficulty hearing. Design plans should include adequate and controllable lighting to facilitate those people who lip-read, or those who require increased task lighting due to a visual impairment.

3.4.7.2 Application Guidelines

Assistive listening systems should comply with this section.

This section applies to areas of public facilities where audible communication is central to the use of the space (e.g., concert theatres, meeting rooms, classrooms, auditoria, etc.). A listening system should be permanently installed where an assembly space accommodates at least 50 people, has audio amplification system or is greater than 100 sq. meters in floor area.

For other assembly areas, there should be either a permanently installed listening system or an adequate number of electrical outlets and/or wiring necessary to support a portable assistive listening system.

Receivers should be available for at least 4 %, but no less than two, of the total number of seats.

3.4.7.3 Technical Guidelines

a. General: Acceptable types of assistive listening systems for people who are hard of hearing include induction loops, infrared systems, and FM radio frequency systems.

b. Location: Fixed seats that provide access to assistive listening systems should be located within 15 m of the stage or playing area and should provide an unobstructed view of the stage or playing area.

c. Signage: The availability of assistive listening systems should be indicated with signage that complies with Section 3.4.1.

d. Induction Loop System: dimmer switches and other controls that incorporate transformer coils should be located so as not to interfere with the audio induction loop where an induction systems are installed. Installed induction loop systems should encompassed at least half the seating area.



e. Infrared System: Overhead incandescent lights should be positioned to prevent disruption of the infrared signal at the receiver where infrared assistive listening devices are used.

f. FM Loop System: In rooms where an FM loop system or other assistive listening devices are used, including meeting rooms, portable headsets that are compatible with personal hearing aids should be made provided.

g. Receiver Jacks: Receivers required for use with an assistive listening system should include a standard 3.2 mm mono jack.

h. Ambient Noise: Ambient and background noise from mechanical systems should be minimized.

3.4.7.5 Other Considerations

3.4.1 Signage

Appendix B Illumination

Appendix B Acoustics



3.4.8 Visual Alarms

3.4.8.1 Design Considerations

For those individuals who cannot hear an audible alarm, such as people who are deaf, deafened or hard of hearing, a visual alarm is the primary method to alert for the threat of danger.

3.4.8.2 Application Guidelines

All visual alarms should comply with this section.

Visual alarm signal appliances should be provided as part of a facility alarm system. Single-station visual alarms should be provided if single-station audible alarms are provided. At a minimum, visual alarm appliances should be provided in each of the following facility areas: Restrooms and any other general usage areas (e.g., meeting rooms), hallways, lobbies and any other areas for common use.

3.4.8.3 Technical Guidelines

a. Location: Visual alarms should be located in addition to audio alarms and should be placed at either 2100 mm above the floor or 150 mm below the ceiling, whichever is lower.

b. Visibility: The maximum distance in any room or space, common corridor or hallway to a visual alarm or a visual signal appliance, should be 15 meters from the signal (in the horizontal plane). In large rooms, such as auditoriums, and for spaces exceeding 30 meters across, without visual obstructions at 2000 mm above the finished floor, visual devices may be placed around the room perimeter, spaced a maximum horizontal 30 meters apart or suspending from the ceiling.

c. Lamp: Visual alarms and signals should be a Xenon strobe type or equivalent.

d. Color: The color of the visual alarm output should be clear or a nominal white (i.e. unfiltered or clear filtered white light).

e. Pulse Cycle: The maximum pulse duration should be two-tenths of one second (0.2 sec) with a maximum duty cycle of 40 percent. The pulse duration is defined as the time interval between initial and final points of 10 percent of maximum signal (set to minimize the risk of triggering an epileptic seizure).

f. Intensity: The intensity of the visual alarm signal should be at least 75 candelas.



g. Flash and Flash Rate: The flash rate should be at least 1 Hz and at most 3 Hz. The visual alarms should be synchronized to flash in unison with flash rates set to minimize the risk of triggering an epileptic seizure.

3.4.8.5 Other Considerations

3.4.9 Emergency Exits, Areas of Rescue Assistance and Fire Evacuation.





3.4.9 Emergency Exits, Areas of Rescue Assistance & Fire Evacuation

3.4.9.1 Design Considerations

Emergency exit doors should be fully accessible, as per the specifications outlined for other doors in this guide. In the event of fire when elevators cannot be used, an area of rescue assistance can be a life-saving respite for people who have difficulty negotiating stairs. All routes of emergency travel should be marked in a way that is understandable to all individuals, including those who may have difficulty with literacy, such as children or people speaking a different language. For people with a visual impairment, an audio or talking sign is a functional tool for locating exits quickly.

3.4.9.2 Application Guidelines

In facilities, or portions of facilities required to be accessible, accessible exits should be provided in the same quantity as the minimum number of exits required by the Kingdom of Saudi Arabia Building Code.

Where an accessible exit from a floor level does not provide level access to the exterior, an area of rescue assistance should be provided instead.

The minimum number of rescue spaces to be provided in each area of rescue assistance should comply with Figure 219.

A horizontal exit, meeting the requirements of the Kingdom of Saudi Arabia Building Code, will satisfy the requirements for an area of rescue assistance.

Figure 219: Number of Rescue Assistance Spaces

Occupant load of the floor area served by the area of rescue assistance	Minimum number of rescue spaces in each area of rescue assistance.
1 to 400	2
Over 400	3 plus 1 for each additional increment of 200 persons in excess of 400 persons

All areas of rescue assistance should comply with this section.



3.4.9.3 Technical Guidelines

a. Emergency Warning Systems: Emergency warning systems should include both audible alarms and visible alarms that comply with Section 3.4.8.

b. Identification Signage: Accessible means of egress should be identified with signage that complies with Section 3.4.1.

c. Areas of Rescue Assistance – Accessible Route: Areas of rescue assistance should be on accessible routes that comply with Section 3.2.2.

d. Areas of Rescue Assistance – Rescue Spaces: Areas of rescue assistance should provide a minimum floor space of 850 x 1400 mm per non-ambulatory occupant. Designated rescue assistance waiting areas located on a stair landing should be located out of the main path of travel, should be clear of all door swings and should be located away from the edges of stairs. Areas of rescue assistance should be separated from the floor area by a fire separation having a fire-resistance rating that is at a minimum equal to that required for an exit. They should be served directly by an exit or fire-fighter's lift and be designated as an area of rescue assistance for people with disabilities on the facility plans and within the facility. Areas of rescue assistance should be smoke protected in facilities of more than three storeys (*Figures 120 to 122*).

e. Areas of Rescue Assistance – Communication System: Areas of rescue assistance should incorporate a 2-way voice communication system for use between each area of rescue assistance and the central alarm and control facility. The communication system should be color contrasted from the surrounding environment, have an audible signal to be detectable by people with visual impairments, and have a volume control.

f. Areas of Rescue Assistance – Signage: Areas of rescue assistance should be identified with signage stating “Area of Rescue Assistance”, include the International Symbol of Access and should comply with Section 3.4.1. The location of areas of rescue assistance should be identified with directional signage, on all publicly displayed floor evacuation plans, be designated in evacuation procedure documents. Evacuation floor plans should be available in alternative formats.

g. Accessible Fire Evacuation Plans: Accessible fire evacuation plans should be displayed and available at strategic and decision making locations throughout the facility. Signage should comply with Section 3.4.1.



3.4.9.4 Illustrations

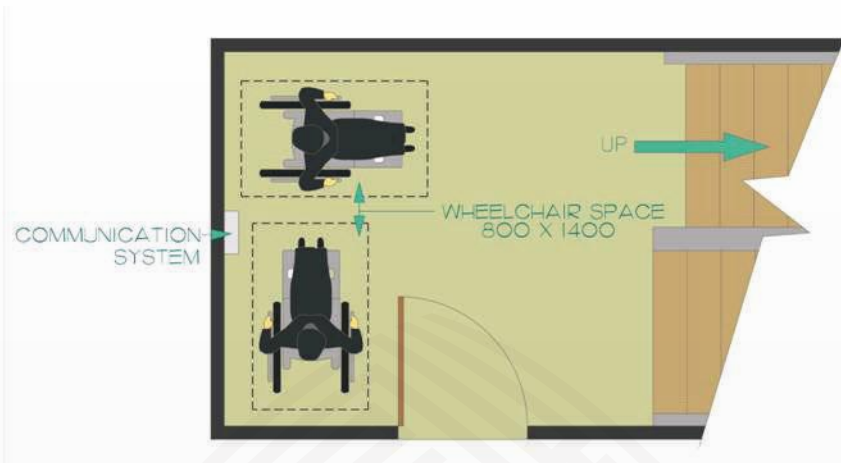

Figure 220: Oversized Landing as Area of Rescue Assistance

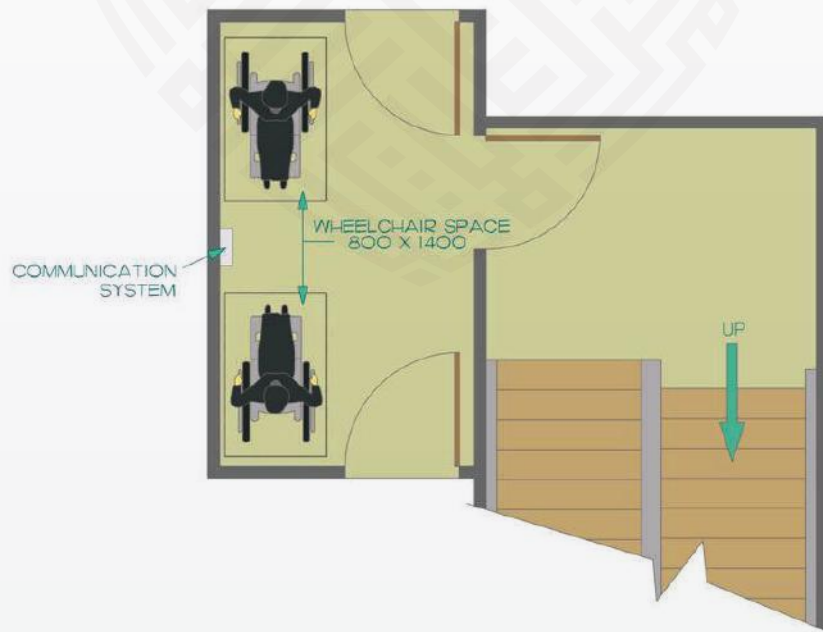

Figure 221: Protected Corridor as Area of Rescue Assistance

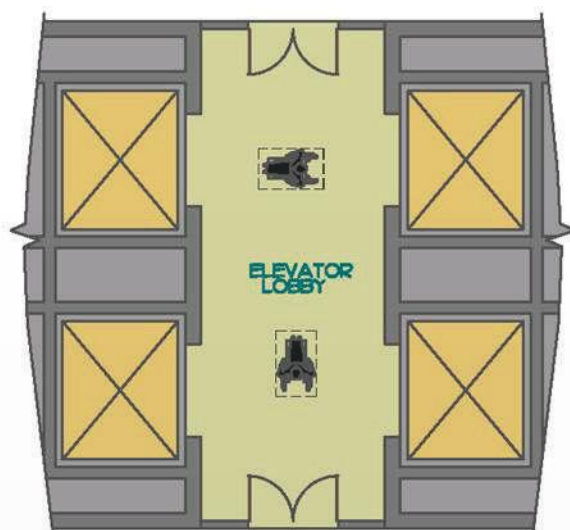

Figure 223: Protected Lift Lobby as Area of Rescue Assistance

3.4.9.5 Other Considerations

- 2.2 Anthropometric Data
- 3.2.2 Routes, Corridors and Access Aisles
- 3.2.9 Doors
- 3.2.25 Floor Surfaces
- 3.2.26 Overhanging and Protruding Objects
- 3.3.10 Controls and Operating Mechanisms
- 3.4.1. Signage
- 3.4.3. Public Address Systems
- 3.4.6 Detectable Warning Surfaces
- 3.4.8 Visual Alarms

Appendix B Materials and Finishes

Appendix B Texture and Color

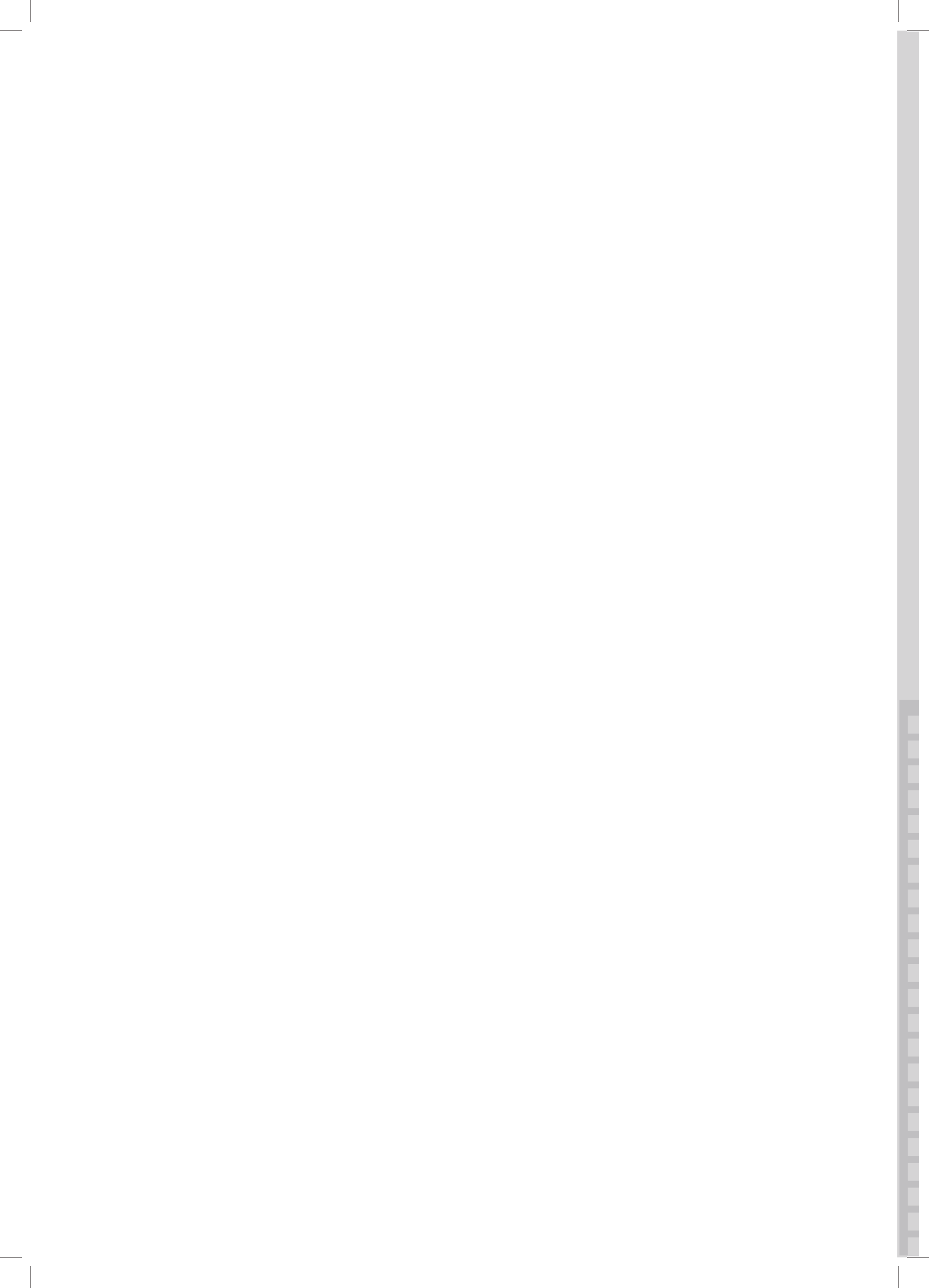

UABE TECHNICAL & DESIGN GUIDELINES

3.5 Building-Specific Requirements





3.5

BUILDING-SPECIFIC REQUIREMENTS

3.5.1

Mosques

3.5.1.1 Design Considerations

Access to all areas of worship and other activity areas in the Mosque should be provided. Access assumes that people with disabilities may be participants, leaders, staff, or volunteers.

3.5.1.2 Application Guidelines

Places of worship and/or reflection should comply with this section.

3.5.1.3 Technical Guidelines

a. General: In addition to complying with this section mosques should comply with applicable design requirements in Sections 3.1 to 3.4. Accessible paths of travel in mosques should be clear of shoes and other obstructions.

b. Seating: Seating should be provided at entrances and at other locations where people are required to remove their shoes. Seating should also be provided within the prayer hall to accommodate people who cannot bend to pray. A designated area to accommodate people using mobility devices should be provided in a location that integrates people with mobility devices into the gathering; Provision should be made to address the potential lack of cleanliness of mobility device wheels where the route to the designated area crosses prayer hall carpeting.



3.5.2 Office and Retail

3.5.2.1 Design Considerations

People with disabilities should not be restricted to the role of a customer or a consumer as they may also be employees. All workspaces must be designed with future adaption and accommodation of assistive devices.

3.5.2.2 Application Guidelines

Business, mercantile and civic facilities should comply with this section.

In facilities that feature elements used for transactions, such as counters where cash registers are provided for sales or distribution of goods or services to the public, a minimum of one counter in each type of transaction area should be accessible and comply with this section; including, but are not limited to, counters in retail stores and distribution centres.

If service/transactions counters are dispersed throughout a facility, accessible service/transactions counters should be similarly dispersed.

Where counters feature solid partitions or security glazing to separate staff from the public, a minimum of one section in each type of counter should allow voice communication. Grills, slats, talk-through baffles, intercoms or telephone handset devices could potentially provide such communication.

The number of accessible checkout aisles provided should be in conformance with Figure 224.

Figure 219: Number of Rescue Assistance Spaces

Occupant load of the floor area served by the area of rescue assistance	Minimum number of rescue spaces in each area of rescue assistance.
1 to 400	2
Over 400	3 plus 1 for each additional increment of 200 persons in excess of 400 persons



3.5.2.3 Technical Guidelines

a. General: In addition to complying with this section, business, mercantile and civic facilities should comply with applicable design requirements in Sections 3.1 to 3.4.

b. Service Counters: Service counters located in business, mercantile and civic facilities should provide clear floor space to allow forward and side approaches by mobility devices that comply with Section 2.2.

c. Communications: In public facilities where counters have solid partitions or security glazing to separate personnel from the public, methods of communication that comply with Section 3.4 should be provided. Methods of communication may also include: grills, slats, talk-through baffles, intercoms or handset devices that comply with Section 3.3.10 and Section 3.4.

d. Checkout Lines: The clear width of accessible checkout lines should comply with Section 3.3.2. Counters adjacent to checkout lines are permitted to have a maximum counter height of 965 mm above the finished floor. The top of any counter edge protection should be no more than 50 mm above the top of the counter surface on the aisle side.

e. Signage: Signage identifying accessible checkout aisles should be provided and should include the International Symbol of Access. Signage should be mounted above the checkout aisle in the same location where the checkout number or type of checkout is displayed and comply with Section 3.4.1.

f. Egress: Any devices used to prevent the removal of shopping carts from store premises should not prevent access or egress to people who use a mobility device. An alternate exit that is equally convenient to that provided for ambulatory persons is permitted.

g. Workspaces: Workspaces are not required to be accessible but should be designed with a view to allow for future adaptation or the accommodation of individual equipment or assistive devices.

3.5.2.5 Other Considerations

- 2.2 Anthropometric Data
- 3.3.2 Queuing and Waiting Areas
- 3.3.10 Controls and Operating Systems
- 3.4 Communications and Safety Systems



3.5.3

Libraries

3.5.3.1 Design Considerations

The design of the Library build and the provision of services should make available to all patrons and staff both traditional and automated systems. Computer catalogues, carrels and workstations should be provided at a range of heights, to accommodate people who are standing or sitting, as well as, children of many ages and sizes. Service counters and study carrels should allow for the knee-space and armrest requirements of a person using a wheelchair.

Providing workstations equipped with assistive technology such as large displays, screen readers, etc. will increase the accessibility of the library.

Book drop-off slots provided at different heights for standing and seated use will enhance usability for all.

3.5.3.2 Application Guidelines

Libraries should comply with this section.

At least 10% of study carrels, fixtures and fixed seating, but never less than one, should be accessible and should comply with this section.

At library check-out areas, at least one check-out lane should be accessible and comply with this section.

At least 50% of computer catalogues or workstations should be accessible and should comply with this section.

3.5.3.3 Technical Guidelines

a. General: In addition to complying with this section libraries should comply with applicable design requirements in Sections 3.1 to 3.4.

b. Seating: Fixed seating, tables, and study carrels should be accessible and on an accessible route in compliance with Section 3.2.2. Clearances between fixed seating, tables, and study carrels should comply with Section 2.2. A minimum of one movable chair should be provided at every information service counter, computer catalogue, or computer workstation.



c. Shelving: Where shelving is provided at fixed study carrels, seating, or near tables, the shelving should be a maximum of 1350 mm above the floor and provide reach ranges from a seated position that comply with Sections 2.2 (*Figure 226*).

d. Study Carrels: Fixed study carrels should provide knee and toe clearances under the work surface that comply with Section 2.2. An electrical receptacle that complies with Section 3.3.10 should be provided at, or in close proximity to, the carrel and should provide reach ranges that comply with Section 2.2.

e. Illumination: Illumination levels of at least 200 lux should be provided at the work surface of all counters, tables, and study carrels. Illumination at book stacks should be mounted directly over the aisle space and provide a minimum of 100 lux at a nominal working height of 900 mm.

f. Clear Aisle Space: The minimum clear aisle space at card catalogues and at stacks should comply with Section 3.2.2. Aisle configurations should incorporate a clear floor space allowing a person in a mobility device to make a 180-degree turn that complies with Section 2.2 (*Figure 225*).

g. Reach Heights: Maximum reach heights at card catalogues should comply with Section 2.2.

h. Shelf Stack Height: Shelf heights in stack areas are permitted to be at any height; Library staff should be available to assist those people who cannot reach higher shelves safely.

i. Computer Catalogues and Computer Workstations: Where provided, computer catalogues and computer workstations should comply with Section 3.3.6. Maximum depth of surfaces should be 900 mm (*Figure 227*).

j. Assistive Technology: Workstations should be equipped with assistive technology such as large displays or screen readers.

k. Book Drop Slots: Book drop slots should be on an accessible route that complies with Section 3.2.2. A clear level floor space measuring a minimum of 2100 mm x 2100 mm should be provided adjacent to book drop slots. In a renovation situation, where it is technically infeasible to provide the required floor space, the clear floor space may be reduced to 1500 x 1500 mm. Book drop slot should be provided at two different heights; one for a standing person and a lower one for a seated/small in stature person that complies with Section 2.2. Book drop slots should be operable using one hand.

l. Acoustic Quality: The acoustic quality of the library should be high and should be free of unnecessary background noise to allow comprehension for people with limited hearing.



m. CDs, Tapes, and Talking Book Auditing Areas: Where talking books, CDs, tapes, etc. are available as part of the library resource materials, or for loan purposes, a separate space should be provided for auditing this material without disturbing other library users. This space should be on an accessible route in compliance with Section 3.2.2.

3.5.3.4 Illustrations

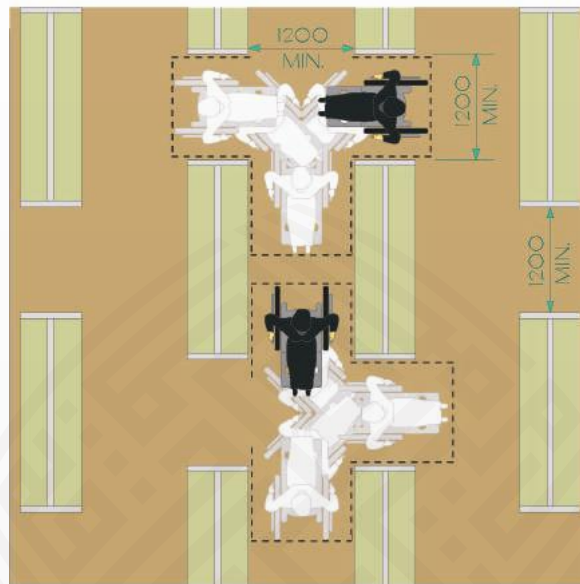

Figure 225: Aisle Width

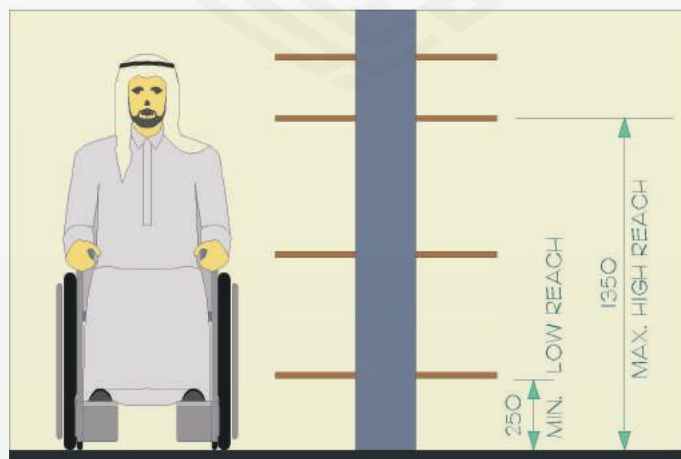

Figure 226: Reach Heights

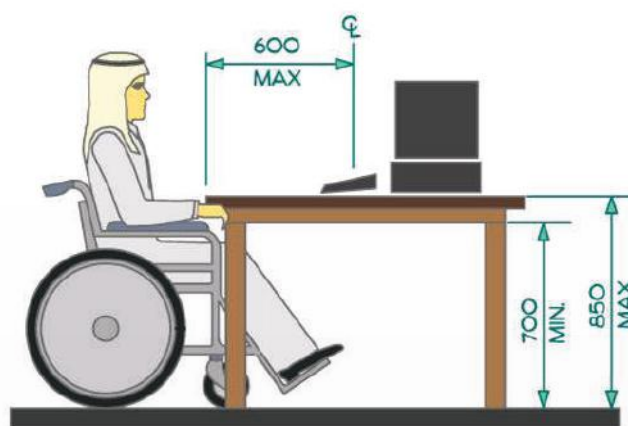

Figure 227: Work Surfaces

3.5.3.5 Other Considerations

- 2.2 Anthropometric Data
- 3.2.2 Routes, Corridors and Access Aisles
- 3.3.6 Tables, Counter and Work Surfaces
- 3.3.10 Controls and Operating Systems



3.5.4 Indoor Recreational Facilities, Halls and Stadiums

3.5.4.1 Design Considerations

Design decisions regarding recreational, leisure and sport-related facilities should take all users into account. Stadiums, halls, arenas and other indoor sports pavilions should all be available to all members of the community. People with a disability may be active participants, spectators, volunteers, or members of staff, and they require equitable access the site, all activity spaces, gymnasia, fitness facilities, lockers, change rooms, and showers.

3.5.4.2 Application Guidelines

Stadiums, halls, arenas, and other indoor recreation facilities should comply with this section.

Dressing facilities provided for use by the general public, clients, customers, performers, or staff should have a minimum of 50% of the facilities, but never less than one in each group of dressing facilities, comply with Section 3.2.24. It would be preferable for all dressing facilities to be accessible.

3.5.4.3 Technical Guidelines

a. General: In addition to complying with this section, stadiums, halls, arenas and other indoor recreation facilities should comply with applicable design requirements in Sections 3.1 to 3.4.

b. Swimming, Hot, or Therapy Pools: Where swimming pool, hot pools, or therapy pools are provided, they should comply with Section 3.5.6.

3.5.4.5 Other Considerations

3.5.6 Swimming Pools



3.5.5 Outdoor Recreational Facilities

3.5.5.1 Design Considerations

Design decisions regarding recreational, leisure and sport-related facilities should take all possible users into account. Playing fields and outdoor sports facilities should be available to all members of the community. People with a disability may be active participants, spectators, volunteers, or members of staff, and they require equitable access to the site, all activity areas, outdoor trails, docks, swimming areas, play spaces, lockers, change rooms, and showers.

3.5.5.2 Application Guidelines

Outdoor recreation facilities listed below should comply with this section.

Dressing facilities provided to support outdoor recreational facilities for the general public, clients, customers, performers, or staff, should have a minimum of 50%, but never less than one in each group of facilities, comply with Section 3.3.4. It would be preferable for all dressing facilities to be accessible.

3.5.5.3 Technical Guidelines

a. General: In addition to complying with this section outdoor recreation facilities should comply with applicable design requirements in Sections 3.1 to 3.4.

b. Boardwalks: Any boardwalks should be on an accessible route and have a minimum clear width of 2000 mm. Boardwalk surfaces should be constructed of firm, stable, and non-slip materials. Where wooden planks are used, they should have joints no greater than 6 wide, be laid perpendicular to the path of travel, and comply with Sections 3.1.1 and 3.1.3. A continuous kerbed edge should be incorporated where the grade drop-off on any side of the boardwalk is greater than 100 mm. The kerbed edge should be at least 75 mm high and be in a contrasting color to the surrounding terrain. Handrails, guards or other suitable barriers should be located on both sides of the boardwalk where the grade drop-off is more than 450 mm. Access points to boardwalks that allow easy wheelchair access should be appropriately located and frequent. Benches, garbage cans, drinking fountains, and other street furniture, where provided, should be located adjacent to the boardwalk on firm, stable, and level surfaces at the same elevation as the boardwalk and should comply with Section 3.1.12.

c. Docks: Where docks for fishing, boating, swimming, or water taxis are provided they should be located on an accessible route that complies with Section 3.1.3. Where changes in elevation are necessary, ramps or kerb cuts should be in compliance with Sections 3.1.6. and 3.1.4. Transitions from a walkway surfaces to a dock or between



adjacent dock units should be firm and level. Transition points should be clearly marked with color contrasting material such as paint or other material. Where possible, the surface of the dock should be no higher than 600 mm above the surface of the adjacent water. On docks that use a continuous kerbed edge, kerb should be in a contrasting color where dock surfaces are less than 450 mm above the surface of the water and at least 100 mm high. Where dock surfaces are greater than 450 mm above the surface of the water should use a guard that comply with Section ????. Where ramps are provided to access the water, the slope should be no greater than 1:12 at low water level. Where steps are provided to access the water, color-contrasting handrails should be provided. Such handrails should extend to a minimum of 600 mm above the dock surface and return down to the dock surface. Where boat loading openings are provided, kerb edges or guards are not required; however color contrast should be maintained at these edge locations (*Figure 228*).

d. Outdoor Pools: Outdoor swimming pools should comply with Section 3.5.6.

e. Urban Trails and Footbridges: Urban trails and footbridges should have surfaces that are firm, stable, and composed of non-slip materials. The slope on bridges should not exceed 1:20. Urban trail routes ideally should have a maximum slope of 1:20. Where significant changes in grade occur, trail routes should be no steeper than 1:12. At steeper locations, steps should be provided and/or the area should be designed as a ramp. Color contrasting for handrails and/or guards should be provided where steps, footbridges or ramps are present.

f. Playgrounds: Children's play areas, playgrounds, and playground equipment, sandboxes, or other amenities should be designed to be accessible to and useable by children with varying levels of ability. Color contrast between surroundings and elements should be incorporated in all play structures. Playground surfaces should be firm, stable, level, be non-abrasive, and drain rapidly. Surfaces below playground equipment, including swings, slides and climbing structures, should be level, free-draining, and provide a softer, resilient landing surface in case of a fall.

g. Picnic facilities: Where provided, picnic facilities should be accessible that comply with Section ????. Where public parking is provided to serve picnic facilities, accessible picnic areas should be within 30 meters of the accessible parking spaces and connected by an accessible route that comply with Section ???.

h. Illumination: Illumination levels should be a minimum of 10 lux. Ground level illumination in all areas of a park and areas of heavy trees and shrubbery should maintained at 5 lux. Light sources used shall provide indirect, non-glare, non-flickering light and provide even levels of light distribution. On higher use pedestrian paths of travel, illumination levels should be at least 30 lux, but at stairs and ramps the Illumination level should be at least 100 lux.



i. Waterfront Areas: Any paths and/or lookout points should be accessible to all individuals. Seating that complies with Section 3.3.7 should be provided along paths and at lookout points. Where parking is provided, it should be located as close as possible to the waterfront area. An accessible route should be provided from the parking area to paths and/or lookout points that comply with Section 3.1.3.

j. Natural Areas: In natural areas, accessible pathways, trails, and footbridges should be provided where environmental considerations will permit. Paths and trails should incorporate rest areas with appropriate seating. Where special lookout locations or wildlife viewing areas are provided, they should be identified with clear signage. Not all trails in natural areas will be able to be made fully accessible to the standards in this document so it is critical at the beginning of a trail system to clearly label if it is accessible or not. Trails should also feature a tactile map at the start of the trail and periodically along its length. Information on the trail head maps should include information such as the length of the trail, minimum widths along the trail, types of surfaces that will be encountered, and maximum slopes along the trail. Information and interpretive signage should incorporate Braille. Complies with Sections 3.1.3, 3.1.12, 3.4.1.

3.5.5.4 Illustrations

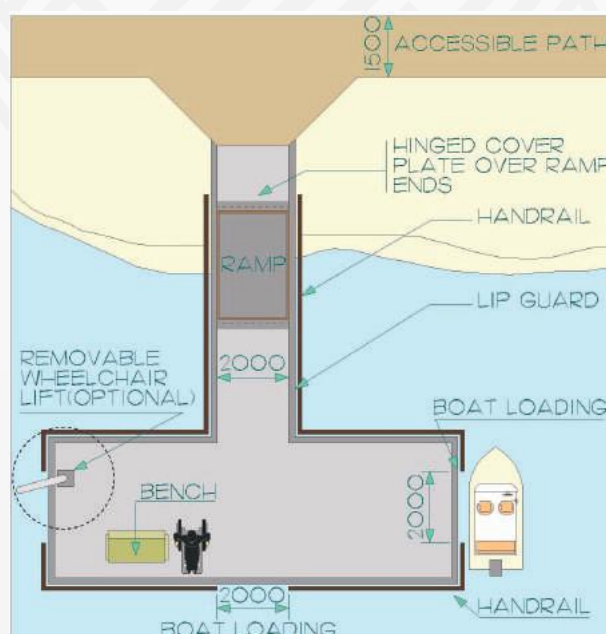

Figure 228: Accessible Dock

3.5.5.5 Other Considerations

3.1.4 Ramps



3.5.6 Swimming Pools

3.5.6.1 Design Considerations

Many people with disabilities will benefit from recreational and therapeutic swimming activities. Immersion in a water environment provides buoyancy and freedom to individuals, which can be enabling in itself. Accommodations for people who have mobility impairments include accessible change facilities and means of access into the water. Ideally water access will be achieved with a ramp, rather than a mechanical lift, as it promotes integration (everyone will use the ramp) and independence. Color and textural clues along primary routes of travel and at potentially dangerous locations, such as the edge of the pool, at steps of the pool and at railings, will aid people who are blind or have with low vision.

3.5.6.2 Application Guidelines

Swimming pools, wading pools, hot pools, splash pads, spray pads, and therapy pools should comply with this section.

3.5.6.3 Technical Guidelines

a. General: In addition to complying with this section, swimming pools, wading pools, hot pools, splash pads, spray pads and therapy pools should comply with applicable design requirements in Sections 3.1 to 3.4.

b. Pool Perimeter Surface: Pool boundaries should be clearly marked with both a textural change and a color contrast to both the water surface and surrounding pavement surface. The floor finishes used on a pool perimeter, deck or paved area surrounding the pool should be firm, stable, slip-resistant, non-abrasive, and easy-to-clean. Pools should be of 'level-deck' design to accommodate various types of mobility devices.

c. Pool Deck Drainage: Pool deck should be designed to drain water quickly. Pool deck slopes in any direction should not be greater than 1:50.

d. Ramped Pool Access: Access from the pool deck into the water should be provided by a ramp sloped no steeper than 1:12. (A ramp slope of 1:16 to 1:20 is preferred.) In renovation situations where it is technically infeasible to provide a ramp, a mechanical pool lift may be used. Ramped access into the water is preferred over lift access. Ramps providing access into pools should include detectable warning surfaces.



e. Sloped Entries: Where sloped entries exist into a pool, they should extend to a depth 610-760 mm below the stationary water level. Where landings are required, at least one landing should be located 610-760 mm below the stationary water level at the bottom of the sloped entry. In wading pools, the sloped entry and landings, if provided, should extend to the deepest part of the wading pool. All sloped entries into pools should include at least two handrails and should provide a clear width between handrails of 950-1200 mm.

f. Pool Transfer Type Chair: A pool / shower type chair should be available at each pool facility, if required for use and assistance in transferring a person with a disability into and out of the pool.

g. Pool Steps or a Ladder: Any steps and/or ladders provided to access the pool should be color contrasted with their surroundings and be marked with a color-contrasting strip of at least 50 mm wide, at both the riser and the tread of each step. The color-contrasting handrails should be located on both sides of the steps and/or ladder. These handrails should extend a minimum of 300 mm beyond the pool edge at deck level and at least to the water surface at the pool level. The handrail should not create a hazard and should return to pool floor, a post, or itself.

h. Kerbed Edge: At a pool, where a kerbed edge is provided, it should be a 200-400 mm in height above the deck floor. It should also be color contrasted from its surroundings.

i. Pool-Depth Indicator: If pool-depth indicator markings are provided, depth - indicator markings, as well as 'SHALLOW END' and 'DEEP END' markings should be a highly contrasting color and a sufficient size to be easily visible for various viewing distances.

j. Diving Boards or Platforms: If diving boards or platforms are provided, they should be clearly marked, protected and color contrasted with their surroundings. Overhead clearances should be at least 2100 mm or protected by suitable guards.

k. Lanes, and/or Lane Markers: If lanes, and/or lane markers are provided, they should be a highly contrasting color. Tie-off devices for lane markers should be positioned so that they do not create a tripping hazard at the pool edge.

l. Starting Blocks: Where starting blocks are provided, they should be a highly contrasting color and capable of being securely fixed in place.

m. Safety Equipment and Other Accessories: Safety equipment and other accessories should be stored so as not to create a tripping hazard, be in clear view, be color contrasted from their surroundings, be on an accessible route, have appropriate



signage indicating the location of the safety equipment clearly visible from all areas of the pool, and have a clear space in front of the equipment of at least 2100 x 2100 mm. The operating parts or access to the safety equipment and other accessories should be located no higher than 1200 mm above the floor.

n. Lifeguard Chairs, Slides, and Other Pool Related Structures: Highly contrasting colors should be chosen for lifeguard chairs, slides, and other pool related structures to the differentiate them from surrounding surfaces.

o. Wading Pool: Wading pool access should be safe and gradual so that a child with a disability can be assisted into the water easily and/or use a pool type wheelchair to enter. All surfaces of the wading pool deck and floor should be slip resistant.

3.5.6.5 Other Considerations

3.1.4 Ramps

3.4.1 Signage





3.5.7 Police Stations

3.5.7.1 Design Considerations

Design of police stations should include considerations that include the needs of a people with disabilities who may be members of the public, detainees, members of counsel, or police staff. All areas that are used by the public, members of staff, and counsel should be fully accessible to people with disabilities. Secure areas should have provisions to accommodate people with disabilities, such as cells and common areas used by detainees.

3.5.7.2 Application Guidelines

Holding cells in police stations should comply with this section.

All common use areas serving accessible cells or rooms and all public use areas should be designed and constructed to comply with 3.1. to 3.4.

Cubicles and Counters: 5%, but not less than one, should comply with Section 3.3.6 on both the visitor and detainee sides. Exception: Non-contact visiting areas not serving accessible cells or rooms.

Partitions: Solid partitions or security glazing separating visitors from detainees through which communication is necessary should incorporate communication systems which are accessible to both individuals who use a wheelchair or mobility scooter and individuals who have difficulty bending. If such communication systems incorporate a telephone handset, at least one telephone handset should be equipped with a volume control.

At least 2%, but not less than one, of the total number of cells should comply with this section. Where special cells are provided (e.g., orientation, protective custody, disciplinary, segregation, detoxification or medical isolation), at least one of each purpose should comply with this section.

In addition to the aforementioned cell requirements, at least 2%, but not less than one, of general cells should be equipped with audible emergency warning systems or permanently installed telephones within the cell, in compliance with this section.

Medical care facilities providing physical or medical treatment or care should be accessible to people with disabilities.



3.5.7.3 Technical Guidelines

a. General: In addition to complying with this section, holding cells, common spaces and routes used by the public, whether in custody or not in custody, visitation and medical facilities within police stations should comply with applicable design requirements in Sections 3.1 to 3.4.

b. Secured Entrances: Entrances used by the public, including those that are secured, should be accessible and comply with Section 3.2.1. Exception: Secured entrances, doors, and doorways operated only by security personnel should not be required to have accessible door hardware.

c. Security Systems: Accessible routes should be provided through fixed security checkpoints. Where security checkpoints incorporate equipment such as metal detectors, fluoroscopes, or other similar devices which cannot be made accessible, an accessible route should be provided adjacent to such security screening devices, to facilitate an equivalent circulation path for people using a wheelchair, mobility scooter, or other mobility device.

d. Beds: Beds should have manoeuvring space of at least 900 mm wide along one side. Preferably the full side of the bed should be accessible.

e. Audible Emergency Warning Systems: Visual and audible alarms should be provided in areas serving occupants of cells, staff, or visitors. Exception: Visual alarms are not required where detainees are not allowed independent means of egress.

3.5.7.5 Other Considerations

3.2.1 Entrances

3.4.8 Visual Alarms



3.5.8 Courthouses

3.5.8.1 Design Considerations

Municipal court facilities should accommodate all people including people with disabilities who may be members of the judiciary, court clerks or other officials, defendants, members of counsel, and members of the public.

Court facilities usually incorporate changes in level at the judge's dais and court officials' areas. While it is not required to make all of these areas fully accessible, it is a requirement that they be easy to adapt, should the need arise in the future to accommodate a person with a mobility impairment. Other areas of the court generally used by the public, defendants, witnesses and counsel should be accessible to all people.

3.5.8.2 Application Guidelines

Courthouses should comply with this section.

In addition to the accessible entrances used by staff or the public, where provided, at least one restricted entrance and one secured entrance to the facility should be accessible. Restricted entrances are those entrances used only by judges, public officials, facility personnel, or other authorized parties on a controlled basis.

Secure entrances are those entrances to judicial facilities used only by detainees and detention officers. Exception: Secured entrances, doors and doorways operated only by security personnel should not be required to have accessible door hardware.

The minimum number of assistive listening device receivers should be 4% of the room occupant load, but not less than two receivers.

3.5.8.3 Technical Guidelines

a. General: In addition to complying with this section, all areas used or accessed by the public, staff, jury members and judges should comply with applicable design requirements in Sections 3.1 to 3.4.

b. Accessible Routes: Where provided, the following elements and spaces should be on an accessible route complying with 3.2.2:

Spectator, Press, and other areas with Fixed Seats: Each spectator, press and other area with fixed seats having a seating capacity of 25 or less, should have within its defined area a clear floor space complying with 2.3. Where the seating capacity of a spectator, press, and other area with fixed seats is greater than 25, seating provision should be provided in compliance with 3.3.2.



Jury Boxes and Witness Stands: Each jury box and witness stand should have within its defined area clear floor space complying with 2.2.

Judges' Benches and Courtroom Stations: Judges' benches, clerks' stations, bailiffs' stations, court reporters' stations, and litigants' and counsel stations should comply with 3.3.6.

Exceptions:

- Vertical access to raised judges' benches or courtroom stations need not be installed, provided that the requisite areas and manoeuvring spaces are installed at the time of initial construction, to allow future installation of a means of vertical access complying with 3.2.3, 3.2.4 or 3.2.6 without requiring substantial reconstruction of the space.
- In alterations, accessible clear floor spaces are not required to be located within the defined area of jury boxes or witness stands and may be located outside these spaces where a ramp or lift access poses a hazard by restricting or projecting into a required means of egress.

c. Security Systems: Accessible routes should be provided through fixed security checkpoints. Where security checkpoints incorporate equipment such as metal detectors, fluoroscopes, or other similar devices which cannot be made accessible, an accessible route should be provided adjacent to such security screening devices, to facilitate an equivalent circulation path for people using a wheelchair, mobility scooter, or other mobility device.

d. Spectator, Press, and Other Areas: Each spectator, press, and other areas with fixed seats having a seating capacity of 25 or less, should provide clear floor space that complies with Sections 2.2. Where the seating capacity of a spectator, press, and other area with fixed seats is greater than 25, seating provision should comply with Section 3.3.3.

e. Jury Boxes and Witness Stands: Each jury box and witness stand should have within its defined area a minimum clear floor space of at least 800x1400 mm and should comply with Section 2.2. In alterations to a jury box or witness stand, accessible clear floor spaces are not required to be located within the defined area of jury boxes or witness stands and may be located outside these spaces where a ramp or lift access poses a hazard by restricting or projecting into a required means of egress.

f. Judges' Benches and Courtroom Stations: Judges' benches, clerks' stations, bailiffs' stations, court reporters' stations, and litigants' and counsel stations should comply with Sections 2.2, 3.2.2, and 3.3.6. Exceptions: Vertical access to raised judges'



benches or courtroom stations need not be installed, provided that the requisite areas and manoeuvring spaces are installed at the time of initial construction, to allow future installation of a means of vertical access complying with Sections 3.2.3, 3.2.4, and 3.2.6 without requiring substantial reconstruction of the space.

g. Assistive Listening Systems: An informational sign indicating the availability of an assistive listening system should be posted in a prominent place both on the interior and exterior of the room.

3.5.8.5 Other Considerations

- 2.2 Anthropometric Data
- 3.2.2 Routes, Corridors and Access Aisles
- 3.2.3 Ramps
- 3.2.4 Stairs
- 3.2.6 Lifts
- 3.3.2 Queuing and Waiting Areas
- 3.3.6 Tables, Counters and Work Surfaces
- 3.4.7 Assistive Listening Devices

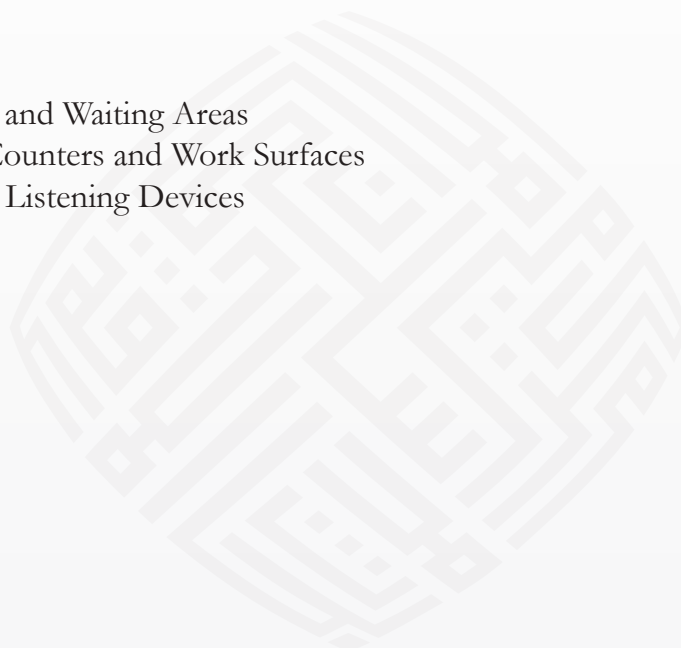



3.5.9

Housing

3.5.9.1 Design Considerations

People with disabilities should be able to live comfortably within a house of their choosing. They should also have the freedom to visit family, neighbours, and friends within their homes.

Accessible housing should be designed to accommodate people who use a wheelchair, mobility scooters or other type of mobility aid, as well as, people with agility, balance, hearing, or visual disabilities.

Visitable housing should incorporate features that allow all guests to enter safely, manoeuvre throughout the entrance level of the house, and have space to access a toilet.

3.5.9.2 Application Guidelines

All new housing units should be visitable and should comply with this section.

All housing units that have major renovations or are conversions from other uses should comply with this section where technically feasible.

The common use areas of all multi-family housing facilities should comply with this section and all other applicable sections from this standard.

3.5.9.3 Technical Guidelines

a. General: The main floor of a single family, row housing, duplex, or apartment dwelling units should at a minimum be compliant with the following section.

b. Apartment or Multi Unit Dwellings: All apartment building or multi family dwelling units and all public corridors, meeting rooms, laundry facilities, offices, public washrooms, or other common areas in these facilities should be accessible and comply with Sections 3.1. to 3.4 and this section. However, if there is more than one level within the apartment building or multi family dwelling units and no lift serves the lower or upper floors, only the main floor area should comply with this section. Where an apartment building or multi unit dwelling has an lift serving other floors in the facility all areas of the facility served by the lift should comply with this section.



c. Exterior Route: An accessible route from the street, sidewalk, or residential parking spaces should be a stable, firm, and slip-resistant surface. The accessible route should be at least 1200 mm wide, have a running slope of no more than 1:25, have a cross slope of no more than 1:25, and comply with Section 3.1.3.

d. Entrance Area: The entrance landing to a visitable dwelling unit should be level with a slope of no more than 1:50 in any direction to accommodate proper drainage. At a minimum, the main entrance to a dwelling unit should be visitable. It is preferred that all entrances to a dwelling unit be visitable. Where it is technically unfeasible to have all or the main entrance visitable, at least one entrance area to the dwelling unit should be visitable and may include an entrance from an enclosed garage area.

e. Illumination: The entrance area to a visitable dwelling unit should be illuminated to a level of at least 200 lux.

f. Entrance Door(s): The entrance door and other doorways on a visitable floor should have a clear opening complying with Section 3.2.1. The threshold at a visitable entrance door should comply with Section 3.2.25.

g. Door Hardware: All doors in a visitable dwelling unit should comply with Section 3.2.9. Door viewers should be supplied at entrance doors to the exterior of the dwelling unit and be located at a height of 1100-1200 mm above the floor.

h. Washrooms: There should be a washroom on the main floor with a door that swings outward, is a sliding door, or with an interior swinging door that allows for a turning circle compliant with Section 2.2. The main floor washroom should at a minimum contain one toilet and one washbasin and be compliant with appropriate Sections of 3.2.

i. Main Floor Circulation: Interior corridors on a Visitable floor should be at least 900 mm wide and have no steps or change in level. There should be a clear route of travel to the toilet with a washroom entrance door that is in compliance with Section 3.2.9. The interior circulation route should also include access to the kitchen and other activity areas on the main floor of the dwelling unit.

j. Windows: Windows on the main floor of a visitable dwelling unit should have sills located no higher than 750 mm above the floor. Opening and locking mechanisms if supplied shall comply with the appropriate parts of Section 3.2.10.

k. Miscellaneous Controls: Operating controls such as electrical switches and outlets, thermostats, communication systems including entrance door bells and intercoms, breaker boxes, exhaust fans, and the main water shut-off valve should comply with the appropriate parts of Section 3.3.10.



I. Adaptation: The possibility of a family member developing mobility impairment, sometime in the future should be considered. Where space allows, the ability to expand a two piece main floor washroom in the future into a full washroom and also containing a bathtub or shower facility is a good idea. In addition, consideration should be made to be able, in the future, to convert a room or area on the main floor into a bedroom or sleeping area for a family member that may become disabled.

3.5.9.5 Other Considerations

- 3.1.3 Sidewalks, Pavement, Paths and Routes
- 3.2.1 Entrances
- 3.2.9 Doors
- 3.2.10 Windows, Glazed Screens and Sidelights
- 3.2.25 Floor Surfaces
- 3.3.10 Controls and Operating Mechanisms



Appendicies





APPENDICES

Appendix A Glossary and Definitions

The following terms are referenced from the Saudi Building Code and other sources as noted:

ACCESSIBLE*: A site, building, facility or portion thereof that complies with these guidelines.

ACCESSIBLE ROUTE*: A continuous, unobstructed path that complies with these guidelines.

ACCESSIBLE ABLUTION UNIT: An area for ablution configured to accommodate a person using a wheelchair or mobility scooter

ACCESSIBLE PARKING SPACE: A parking space configured to accommodate a person using a wheelchair or mobility scooter

ACCESSIBLE TOILET STALL: A toilet stall configured to accommodate a person using a wheelchair or mobility scooter

CANE-DETECTABLE:** Any object or a change in surface texture that falls within the detection range of a long white cane.

CIRCULATION PATH*: An exterior or interior way of passage from one place to another for pedestrians.

COMMON USE*: Interior or exterior circulation paths, rooms, spaces or elements that are not for public use and are made available for the shared use of two or more people.

Color CONTRAST:** A significant contrast in color between the foreground and the background of an element, i.e., light on a dark background or dark on a light background (70% contrast between characters and the background is considered an appropriate contrast for people with low vision).

DETECTABLE WARNING*:** A standardized surface feature built in or applied to walking surfaces or other elements to warn visually impaired persons of hazards on a circulation path.

EMPLOYEE WORK AREA*: All or any portion of a space used only by employees and only for work. Corridors, toilet rooms, kitchenettes and break rooms are not employee work areas.

FACILITY*: All or any portion of buildings, structures, site improvements, elements and pedestrian or vehicular routes located on a site.

LIMITED MOBILITY ABLUTION UNIT: An area for ablution configured to accommodate a person who uses a mobility aid such as a walker, canes or crutches.



LIMITED MOBILITY PARKING SPACE: A parking space configured to accommodate a person who uses a mobility aid such as a walker, canes or crutches.

LIMITED MOBILITY TOILET STALL: A toilet stall designed to accommodate a person who uses a mobility aid such as a walker, canes or crutches.

MOBILITY SCOOTER: A mobility scooter is a mobility aid similar to a wheelchair but configured like a motor mobility scooter. It is often referred to as a power-operated vehicle/mobility scooter or electric mobility scooter.

MOTORIZED WHEELCHAIR: a self-propelled wheeled device powered by a motor, designed solely for and used by a mobility-impaired person for locomotion

PUBLIC ENTRANCE*: An entrance that is not a service entrance or a restricted entrance.

PUBLIC-USE AREAS*: Interior or exterior rooms or spaces that are made available to the general public.

RESTRICTED ENTRANCE*: An entrance that is made available for common use on a controlled basis, but not public use, and that is not a service entrance.

SERVICE ENTRANCE*: An entrance intended primarily for delivery of goods or services.

SITE*: A parcel of land bounded by a lot line or a designated portion of a public right-of-way.

TACTILE SIGNS: Signage incorporating raised text and/or symbols to enable touch reading by the blind and touch enhancement of visual perception for vision impaired readers.

TECHNICALLY INFEASIBLE*:** Means, with respect to an alteration of a building or a facility, that it has little likelihood of being accomplished because: existing structural conditions would require moving or altering a load-bearing member which is an essential part of the structural frame; or other existing physical or site constraints prohibit modification or addition of necessary elements, spaces or features which are in full and strict compliance with the minimum requirements for new construction.

VISITABLE: The ability of a dwelling unit to offer a reasonable level of access to accommodate visitors with disabilities, elderly persons or residents who may be temporarily disabled – allowing people to access the dwelling safely via a level entry, manoeuvre independently throughout the entry level, and utilize a toilet.

WHEELCHAIR SPACE: A space for a single wheelchair and its occupant.

* *Source: Saudi Building Code*

** *Source: CAN/CSA B651-04: Accessible design for the built environment*

*** *Source: City of London Facility Accessibility Design Standards*



Appendix B | Additional Design Considerations

B1. Glare and Light Sources

Design Considerations

People with reduced vision, indeed everyone, may experience discomfort from direct or reflected glare from floors, walls, or work surfaces. Where practical, consideration should be given to the reflective properties of light sources, materials, and finishes selected. Also, their ability to absorb and/or direct light that may be present in a space.

All individuals will benefit from the strategic use and placement of lighting, especially those with some form of visual impairment. Additionally, the provision of task lighting at work areas is beneficial to all.

Guidelines

GENERAL*: Extensive high gloss floor and wall finishes are not desirable, but high-gloss materials may be incorporated into floor and wall finish details, provided they do not result in large reflective surfaces. Monolithic floor surfaces, such as stone, granite, marble or terrazzo, should have a matte or honed finish, to minimize reflected glare.

HORIZONTAL SURFACES*: Finishes such as vinyl, other composition materials, quarry tile, glazed tile or mosaics, used on horizontal surfaces, such as floors and work surfaces, should be in matte or satin finishes.

VERTICAL SURFACES*: Finishes such as paint, vinyl wall coverings, stone, marble, wood, metals, plastic laminate, etc., used on vertical surfaces, such as walls and columns, should have matte or satin finishes.

CURTAINS/BLINDS*: Curtains, blinds or other sun-screening systems should be provided at windows and other places where direct sunlight can adversely affect the level of lighting and/or reflected glare.

LIGHT FIXTURES*: Light fixtures should be selected with diffusers, lenses or recessed light sources, so that no glare is created. Where surface-mounted fluorescent ceiling fixtures are mounted below 2440 mm, they should have darkened sides (i.e., not wrap-around lenses) and be positioned perpendicular to the dominant direction of travel, or used in valance-type lighting along the perimeter of a space, resulting in indirect lighting.



SUPPLEMENTARY LIGHTING*: The location of special features and key orientation elements should be enhanced through the use of supplementary lighting; supplementary lighting should have upward or downward components only.



* *Source: City of London Facility Accessibility Design Standards*



B2. Illumination

Design Considerations

Even distribution of artificial lighting and natural light sources is beneficial for everyone in working areas, along circulation routes and in areas where potential hazard are present. Entrances, frequently used access routes and frequently used outdoor amenities, should be illuminated.

Guidelines

EXTERIOR LIGHTING

GENERAL*: Exterior lighting should be provided in all public thoroughfares, and at all pedestrian routes, to provide safe access for persons with disabilities from sidewalks, bus stops and parking areas to nearby facilities and site amenities.

PEDESTRIAN ENTRANCES*: At pedestrian entrances, lighting levels should be at a minimum 150 lux and be consistent over the entrance area, measured at the ground.

PEDESTRIAN ROUTES*: Over frequently used pedestrian routes, including walkways and paths, lighting levels should be at a minimum 30 lux and be consistent over the route, measured at the ground. At exterior stairs and ramps the minimum illumination level should be 100 lux.

DESIGNATED PARKING*: At designated parking spaces including accessible spaces and limited mobility/caregivers spaces, lighting levels should be at a minimum 30 lux and be consistent over each of these parking spaces, measured at the ground.

PASSENGER DROP-OFF AREAS*: Lighting levels at passenger drop-off areas should be minimum 30 lux and be consistent over the drop-off area, measured at the ground.

STAIRS*: At frequently used steps and stairs, lighting should be located at or beside the steps or stairs, to clearly define the treads, risers and stair nosing.

SUPPLEMENTARY LIGHTING*: Supplementary lighting should be provided to highlight key signage and orientation landmarks.

LOW LEVEL LIGHTING*: Lighting located at low levels above grade should be high enough above grade to clear adjacent bushes and shrubs.

EXTERIOR ILLUMINATION PROPERTIES*: All lighting should provide a good color spectrum; and be evenly distributed to minimize cast shadows.

* *Source: City of London Facility Accessibility Design Standards*



INTERIOR LIGHTING

INTERIOR LIGHT FIXTURES*: Light sources and fixtures should be selected to minimize direct glare or indirect glare on nearby reflective surfaces.

INTERIOR ILLUMINATION PROPERTIES*: Light sources should provide as full a spectrum of light as possible, as an aid to edge and color definition. Lighting should be configured to create an even distribution at floor level and to minimize pools of light and areas of shadow.

* *Source: City of London Facility Accessibility Design Standards*

Space/Location	Recommended Illumination Level(s)
Accessible Routes Paths and Corridors, including stairs, ramps and escalators	Average of 200 lux measured at the walking surface, and in no place less than 50 lux. The leading edge of stairs, steps, ramps or escalators should be evenly lit to minimize tripping hazards.
Signs, Switches, Keypads, Public Telephones, Information Counters, Service Counters.	No less than 200 lux, measured at the work surface or control
Elevators and Elevator Lobbies	No less than 200 lux, measured at the cab floor level. Lighting levels in elevator lobbies should be similar to the lighting levels in elevator cabs, to minimize tripping hazards.No less than 200 lux, measured at floor level
Washrooms & Dressing Rooms	No less than 100 lux, measured at desk height. Task lighting which provides illumination of at least 200 lux should be provided in areas where reading is required.
Offices	No less than 200 lux, measured at table height. Lighting in meeting rooms should be capable of being adjusted (e.g., dimmers).
Meeting Rooms	Lighting in assembly areas should be capable of being adjusted (e.g., dimmers).
Assembly Areas	Lighting at lecterns, podiums/platforms or other speaker locations should be capable of being enhanced, even when other lighting is dimmed, to permit ease of lip-reading and/or viewing of the hand actions of a nearby signer for people who are deaf.



B3. Materials and Finishes

Design Considerations

Access for people using mobility aids and people with low vision, can be directly affected by the selection of flooring materials. Choosing appropriate floor finishes will enhance safety, facilitate ease of movement, and minimize energy usage.

Slip-resistant finishes with minimal reflective glare are safer and more usable for everyone.

Guidelines

STEPS*: Steps should be finished with a non-slip material and incorporate highly contrasted stair nosing.

HANDRAILS & GUARDS*: Handrails and guards should be continuous, smooth and well maintained.

WALKWAY SURFACES*: Suitable walkway paving surfaces include macadam, concrete, compacted gravel screenings, interlocking brick and patio stones.

GRATINGS & GRILLES*: Where possible, gratings and grills should be located to one side of the pedestrian walkways, so as not to impede the accessible route. Where this is not possible, the bars of the grating or grill should be located perpendicular to the dominant path of travel, with openings of no greater than 13 mm.

CARPET*: Carpet should be of low-level loop construction, 10 or 12-gauge non-static fibre and directly glued to the sub-floor.

FIRM SURFACES*: Where hard, monolithic materials are selected, they should be non-slip and non-glare. Where floor tiles, bricks or pavers are used, joints should be no wider than 6 and should be flush with the surrounding surface.

WALL SURFACES*: Wall surfaces in corridors should be non-abrasive from the floor level to a minimum of 2000 mm above the finished floor.

* *Source: City of London Facility Accessibility Design Standards*



B4. Texture and Color

Design Considerations

The ability of an individual with a visual impairment to navigate an environment can be enhanced through the strategic use and placement of color and texture. Caution is recommended in the selection of heavy, dark areas, or distinct patterns on walls or floors, since these can add visual confusion to settings for people with low vision. Simple, repetitive, non-directional patterns that feature monochromatic or low-color contrast are preferred. Changes in material or texture should be level and should avoid the need for a threshold.

Guidelines

EXTERIOR Color SCHEMES*: A pronounced contrasting color scheme will aid with the differentiation of boundaries of objects, distinguish objects from their background, and generally enhance spatial orientation. Generally, for seniors and people with low vision, colors in the warm end of the spectrum (yellow, orange, bright red, etc.) are easier to recognize than those at the cool end of the spectrum.

SIGNAGE*: Signs should incorporate pronounced glare-free color contrast. A minimum contrast of 70% light reflectance is required. For signs, the most visible colors are white or yellow on a black, charcoal or other dark background, such as brown, dark blue, dark green or purple. Black lettering on white is also acceptable, although less readable than the reverse. Unacceptable background colors are light grey and pastel colors. Red lettering on a black background is also unacceptable.

SAFETY*: Color contrast should be used as a safety measure to define edges or boundaries of objects (e.g., stair nosing, doors, handrails, etc.). Color or tone should be used to visually define the boundaries of a room (i.e., where the wall meets the floor). Baseboards in monochromatic environments should be highly contrasting with the wall and floor colors, to provide boundary definition. Color should be used consistently to visually identify distinctive objects (e.g., exit doors).

WAY-FINDING*: Bright colors and/or a highly contrasting tone should be used to assist with way-finding. (e.g. If used as part of a signage band located on walls at eye level, this band is easier to follow than monolithic wall coloring, and can be the visual cue for other essential signs.) End walls or return walls in long corridors should be visually defined using highly contrasting colors or tone, to enhance a change of direction or the end of the space.



GLAZING*: Large areas of glass should be avoided, where they do exist, horizontal contrasting strips should be applied for the full width of the glass.

DOORS & DOOR FRAMES*: Door hardware should be of a contrasting color from the door surface. Doors and doorframes should be color contrasted from the surrounding surfaces. Doors composed entirely of glass should be avoided.

DETECTABLE WARNING SURFACES*: Detectable warning surfaces should be used to define potential hazards. All textured surfaces used as detectable warning surfaces should be clearly detectable by walking upon and be different from the surrounding surface. Suitable textures for detectable warning surfaces could include a 10 mm deep saw-cut concrete with regular grooves, positioned no more than 100 mm apart, commencing no closer than 100 mm from the curb, grooves should be at right angles to the path of travel for exterior textures. Where this solution is used it should be ensured that the grooves are kept clear of sand and other debris at all times in order for them to be cane detectable. Also appropriate, are raised domes, dots or squares, deeply grooved concrete, terrazzo or other stone-like materials, with closely centred grooves at right angles to the path of travel, or applied carborundum or other non-slip strips for interior textures.

SUPPLEMENTARY TEXTURAL CUES*: Supplementary textural cues should also be provided (e.g., by using different floor textures or materials, in major and minor routes). Clearly defined boundaries of materials like carpeting or floor tiles should enhance way-finding by defining such as the junction between walls and floors, doorway recesses and corridor intersections. The same texture should be used consistently throughout any one site to identify the same type of hazard.

PATTERNS*: Heavy or pronounced patterns on walls or floors should be avoided to avoid visual confusion.

* *Source: City of London Facility Accessibility Design Standards*



B5. Acoustics

Design Considerations

People who are hard of hearing, and those who need to differentiate essential sounds from general background noise, are directly affected by the acoustic environment in which they operate. The sound transmissions of different areas can be used as an orientation cue and help to navigate a space. A well designed acoustical environment is to everyone's advantage.

Guidelines

FLOOR FINISHES*: Floor finishes, wall surfaces and ceilings should be selected so that occasional noise is not unduly amplified. (e.g., Hard surfaces such as marble or terrazzo will allow each foot step to be heard by people who are visually impaired, but add another level of confusion for people who are hearing impaired.)

WAY-FINDING*: At accessible routes in large facilities where way-finding is problematic, the sound transmission/reflection characteristics of finish materials should aurally differentiate major and secondary paths of travel.

CEILINGS*: Ceiling shapes should be designed so that echoes do not occur, unless an alternate acoustical treatment is incorporated. (Note: domed shapes tend to distort sound.)

PUBLIC ADDRESS SYSTEMS*: Public address and call systems should be capable of being zoned to key areas, rather than blanketing all areas of a facility at all times.

MEETING ROOMS and ASSEMBLY AREAS*: In meeting rooms and assembly areas where the spoken word is key to comprehending the proceedings, all unnecessary background noise (e.g., from fans or other mechanical equipment, air diffusers, etc.) should be dampened and/or the room should include adequate sound insulation.

* *Source: City of London Facility Accessibility Design Standards*



The following is a list of ISO Symbols for accessible signage.

<source SIO/CD 21542.2>



Accessible Facility or Entrance (UK)



Accessible Parking (UK)



Accessible Toilet Unisex (modified UK)



Accessible Toilet for Woman (UK)



Accessible Toilet for Man (UK)



Accessible Lift (UK)



Mobility Impaired (UK)



Guide Dogs Allowed (UK)



Facilities for Vision Impaired (UK)



Blind Person (World Blind Union)



Facilities for Hearing Impaired (World Federation of the Deaf Symbol)



Induction Loop System (World Federation of the Deaf Symbol)



Infra-red System (World Federation of the Deaf Symbol)



Telephone Amplification (ETSI)



Text Telephone (UK)



Video Telephone Suitable for lip reading (ETSI)



Assistance Available (International Symbol of Assistance)



Appendix E | References

Abbreviation	Full
mm	millimetres
C	Celsius
CD	Compact Disk
ICT	Information and Communication Technologies
FM	Frequency Modulation
GPS	Global Positioning System
Hz	Hertz
kN	Kilo newtons
LU/LA	Limited Use, Limited Access
Min	Minimum
Max	Maximum
N	Newtons
PSCDR	Prince Salman Centre for Disability Research
TTY	Tele-typewriter (Text Telephone)
UABE	Universal Accessibility of the Built Environment
UALT	Universal Accessibility Land Transportation
UAP	Universal Accessibility Program
UDA	Universal Design Associates

Architectural and Transportation Barriers Compliance Board (The Access Board), (Washington, D.C. 2004.)

“Americans with Disabilities Act Accessibility Guidelines “(ADAAG) –2002 and the “Architectural Barrier Act” (ABA) Accessibility Guidelines -2004. U.S.

Betty Dion Enterprises (Ottawa, Ontario, Canada). March 2000.

“International Best Practices in Universal Design: A Comparative Study” Volume 1 and 2. Betty Dion Enterprises in partnership with The Canadian Institute on Barrier-Free Design, University of Manitoba, Faculty of Architecture.

Building Plan Department, Building and Construction Authority (Singapore). 2002.

“Code on Barrier-Free Accessibility in Buildings.” (ver. 1.0)



Canadian Commission on Building and Fire Codes (Ottawa, Canada.) 2005.
“National Building Code of Canada.” National Research Council.

Canadian Human Rights Commission (Ontario, Canada). March 2006.
“International Best Practices in Universal Design: A Global Review.”

Canadian Standards Association (CSA). 2004.
“Accessible Design for the Built Environment.” CAN/CSA B651-04

Canadian Standards Association (CSA). 2007.
“Accessible design for self-service interactive devices.” CAN/CSA B651.2-07

Canadian Standards Association (CSA). 2007.
“Safety Code for Lifts.” ASME A17.7/CSA B44-.7

Canadian Standards Association (CSA). 2008.
“Inclusive design for an aging population.” CAN/CSA B659-08

City of London 2007 Facility Accessibility Design Standard (Ontario, Canada). 2007.

City of Winnipeg 2006 City of Winnipeg Accessibility Design Standard (Manitoba, Canada). 2006.

Corporation of London (England). 2006. “Designing An Accessible City.”

Council of Standards Australia (Sydney, Australia). 2005.
“Access For People with Disabilities.” Committee ME/64 – Design for Access and Mobility. Part 1: General Requirements for Access – New Building Work. AS 1428.1 – 2001; Design for Access and Mobility. Part 2: Enhanced and additional requirements – Buildings and facilities. AS 1428.2 – 1992; Design for Access and Mobility. Part 3: Requirements for children and adolescents with physical disabilities AS 1428.3 - 1992; Design for Access and Mobility. Part 4: Tactile indicators AS 1428.4 – 2002.

Department of the Environment, Transport and the Regions and the Welsh Office (London, England). 2004.
“The Building Regulations 2000. Access and facilities for disabled people.” APPROVED DOCUMENT M – 2004 Edition. The Stationary Office.

International Codes Council. 2003.
“Accessible and Usable Buildings and Facilities.” ICC/ANSI A117.1

International Codes Council. 2006.
“International Building Code 2006.”



Japan International Cooperation Agency (Japan). 1994.

“The Act on Buildings Accessible and Usable for the Elderly and Physically Disabled No.44”. Ministry of Construction, Building Centre of Japan

Ministry of Social Affairs; National Committee for the Disabled. 1994.

“Accessibility for the Disabled: A Design Manual for a Barrier Free Environment.” United Nations Economic and Social Commission for Western Asia (ESCWA) and the Urban Management Department of the Lebanese Company for the Development and Reconstruction of Beirut Central District (SOLIDERE).

Nova Scotia Canada.

“Building Code Act.” Chapter 46 of the revised statutes, 1989, amended 1990, c. 19,s.35; 1994-95,c. 7,s.2; 1998,c. 18,s.550; 2005,c.47

The Swedish Board of Housing, Building and Planning (Sweden). 2002.

“Building Regulations” - BBR. Mandatory provisions and general recommendations.

Universal Design Institute (Winnipeg, Manitoba). 2000.

“Access: A Guide to Accessible Design for Designers, Builders, Facility Owners and Managers.” University of Manitoba, Faculty of Architecture.



Appendix F

Subject Index

Abbreviation / Acronym:	254
Ablution hose:	150,156
Ablution spaces:	134
Accessible washroom:	131
Acoustics:	283
Adult manual wheelchair:	25
Assistive Listening Systems:	244, 270
Balconies, porches, terraces & patios:	79
Barrier free design:	17
Bathtubs:	162
Best practice:	286, 287
Braille:	101, 102, 229, 230, 239, 262
Business, mercantile & civic:	253, 254
Card access, safety & security systems:	240
Changes in level:	31, 32, 36, 84, 188, 189, 268
Checklist:	8, 262
Clear floor space:	19, 20, 21, 22, 26, 27, 131, 132, 143, 153, 156, 159, 163, 164, 167, 169, 174, 175, 176, 177, 178, 184, 185, 196, 202, 206, 207, 212, 214, 216, 219, 222, 235, 254, 256, 268, 269
Clearances:	20, 21, 23, 25, 60, 67, 132, 175, 207, 255, 256, 264
Clearances at doors:	120
Cognitive disability:	81, 116
Controls & operating mechanisms	78, 83, 93, 106, 108, 110, 115, 125, 128, 133, 136, 141, 147, 151, 154, 158, 161, 166, 171, 175, 195, 206, 215, 216, 217, 219, 220, 237, 239, 241, 251, 273
Courthouses	82, 268
Courtyards and balconies	79
Detectable warning surfaces:	14, 32, 35, 38, 41, 44, 46, 48, 49, 50, 51, 53, 56, 57, 58, 66, 69, 75, 87, 90, 93, 95, 97, 98, 113, 193, 204, 205, 242, 243, 251, 263, 282
Doors:	12, 40, 44, 46, 48, 78, 79, 80, 81, 82, 83, 85, 86, 89, 93, 96, 97, 99, 101, 106, 108, 110, 116, 117, 118, 119, 120, 121, 122, 123, 125, 126, 127, 129, 131, 133, 134, 136, 137, 138, 141, 143, 144, 145, 147, 156, 169, 174, 177, 184, 195, 218, 233, 241, 248, 251, 267, 268, 272, 273, 281, 282
Dressing rooms	184, 185, 186, 189, 218, 228, 233
Drinking fountains	14, 218, 221, 222, 243, 260



Edge protection	36, 38, 39, 40, 44, 86, 88, 89, 93, 254
Egress	112, 113, 114, 115, 201, 229, 249, 254, 267, 269
Emergency exits, fire evacuation & areas of rescue assistance	116
Entrances	14, 61, 81, 82, 83, 98, 101, 116, 117, 118, 132, 167, 189, 202, 229, 223, 241, 252, 267, 268, 272, 273, 278
Escalators	98, 111, 189, 230, 243
Family toilet rooms	117, 131, 133, 137, 138
Feedback form	301
Floor surfaces	30, 44, 53, 56, 58, 66, 69, 75, 86, 93, 97, 98, 101, 106, 110, 115, 118, 132, 133, 141, 167, 175, 178, 185, 187, 188, 199, 203, 205, 213, 224, 251, 273, 276
Forward reach	21, 24
Gates, turnstiles and openings	83, 125, 194, 218
Glare and light sources:	14, 38, 44, 48, 53, 56, 58, 87, 97, 98, 106, 110, 115, 133, 136, 141, 175, 183, 189, 197, 199, 276
Grab bars:	133, 138, 141, 142, 143, 145, 147, 148, 149, 150, 151, 155, 156, 157, 162, 163, 164, 166, 167, 168, 169, 171, 172, 185, 187, 133, 138, 141, 142
Grills and gratings:	32
Ground surfaces:	30, 31, 37, 38, 48, 59, 62, 67, 71, 72, 79, 80, 87, 201, 211, 224, 261
Guidelines:	9, 10, 11, 12, 13, 14, 15, 19, 28, 29, 30, 31, 33, 36, 39, 45, 50, 54, 57, 60, 61, 67, 71, 73, 77, 79, 82, 85, 88, 95, 98, 100, 101, 108, 111, 112, 116, 117, 126, 131, 134, 137, 143, 148, 152, 153, 155, 156, 159, 162, 163, 167, 172, 174, 176, 184, 188, 191, 194, 196, 198, 200, 201, 204, 206, 207, 212, 214, 216, 219, 222, 225, 226, 229, 230, 234, 235, 238, 239, 240, 242, 243, 244, 246, 248, 249, 252, 253, 254, 255, 259, 260, 263, 266, 267, 268, 271, 274, 278, 280, 281, 283, 286
Handrails:	39, 40, 41, 44, 46, 48, 88, 89, 90, 93, 94, 95, 96, 97, 102, 106, 110, 112, 115, 184, 185, 187, 198, 202, 213, 225, 226, 243, 260, 261, 264, 280, 281
Housing:	271, 288
Illumination:	7, 14, 37, 38, 41, 44, 46, 48, 66, 69, 82, 83, 86, 87, 90, 93, 96, 97, 98, 102, 106, 110, 113, 115, 132, 133, 136, 141, 147, 151, 158, 161, 164, 166, 169, 171, 173, 175, 183, 185, 197, 199, 204, 205, 215, 217, 218, 224, 231, 233, 236, 237, 241, 245, 256, 261, 272, 278, 279, 290
Indoor recreational facilities, halls & stadiums:	7, 259, 290
Induction loop: Counters:	6, 196 6, 14, 153, 175, 176, 196, 197, 207, 253, 254, 255, 256, 266, 270, 279, 299, 218



Information systems:	6, 78, 82, 83, 125, 195, 197, 199, 218, 231, 239
International access symbols:	14, 232, 284
International Standards Organization (ISO)	14
Kerb cuts:	51, 54, 55, 57, 66, 68, 69, 243, 260, 81, 36, 38, 44, 49, 50
Kitchens and kitchenettes	6, 176
Knee and toe clearance	25, 175, 256
Landscaping materials and plantings	5, 70, 71
Libraries	7, 14, 101, 255
Lift	5, 12, 14, 31, 36, 54, 67, 85, 99, 100, 101, 102, 103, 104, 106, 107, 108, 109, 110, 111, 113, 188, 189, 233, 241, 249, 251, 263, 269, 270, 271, 284, 287
Lighting	98, 174, 175, 214, 219, 240, 244, 276, 277, 278, 279
Lockers and baggage storage	212
Materials and Finishes	14, 32, 35, 38, 44, 48, 53, 56, 58, 66, 69, 75, 80, 87, 93, 97, 98, 106, 110, 115, 133, 136, 141, 175, 183, 193, 197, 199, 203, 205, 211, 224, 251, 280
Medians and middle Islands	53, 57
Mosques	14, 136, 252
Moving walks	14, 111, 112, 113, 243
Offices, work areas, & meeting rooms	218, 241
Outdoor recreational facilities	260
Parking	13, 59, 60, 61, 62, 63, 64, 65, 67, 82, 229, 223, 243, 261, 262, 272, 274, 275, 284
Passenger drop-off areas	67, 241, 243, 278
Pedestrian crossings	13, 53, 54, 55
Platform	12, 14, 38, 87, 100, 101, 106, 107, 108, 109, 118, 189, 204, 205, 212, 218, 233, 241, 242, 243, 264
Platform lifts	100, 106, 107, 108, 189, 218, 233, 241
Police stations	14, 82, 266, 267
Protruding and overhead objects	69, 183, 235
Public address systems	106, 110, 197, 199, 238, 251, 283
Public telephones	199, 218, 233, 234, 235
Raised platforms and stages	204
Ramps, exterior	39, 228, 243
Ramps, interior	87, 88, 228, 243
Rest areas and benches	209
Routes, corridors and access aisles	75, 84, 85, 86, 136, 175, 183, 187, 189, 203, 205, 206, 208, 218, 220, 224, 237, 251, 258, 270
Security systems	78, 83, 106, 110, 125, 141, 195, 218, 240, 267, 269
Showers	133, 167, 168, 175, 185, 218, 259, 260
Side reach	20, 23, 24
Sidewalks, pavements, paths and routs	32, 35, 36, 37, 66, 69, 72, 80, 193, 211, 224, 233, 241, 243, 273, 278



Signage	14, 37, 38, 41, 44, 48, 61, 62, 63, 66, 67, 69, 78, 82, 83, 85, 87, 90, 93, 97, 98, 101, 106, 108, 110, 115, 125, 129, 131, 133, 136, 137, 141, 174, 194, 195, 197, 199, 202, 203, 219, 229, 230, 231, 235, 236, 237, 244, 245, 249, 251, 254, 262, 265, 275, 278, 281, 284
Speaker podiums and lecterns	206
Stairs, exterior	45, 46, 228, 243, 278
Stairs, interior	94, 95, 228, 243
Street furniture	13, 38, 73, 74, 218, 260
Storage, shelving and display units	136, 175, 214, 218
Swimming pools	14, 185, 259, 261, 263
Tables, counters and work surfaces	175, 207, 270
Texture and color	14, 32, 35, 38, 44, 48, 53, 56, 58, 66, 69, 73, 75, 80, 87, 93, 97, 98, 106, 110, 115, 133, 136, 141, 147, 151, 154, 158, 161, 166, 171, 173, 175, 183, 193, 197, 199, 203, 205, 211, 220, 224, 228, 233, 237, 241, 251, 281
Toilet (Water closet)	12, 14, 117, 129, 131, 132, 133, 135, 136, 137, 138, 139, 140, 141, 142, 143, 144, 145, 146, 147, 148, 149, 150, 151, 159, 166, 171, 173, 189, 218, 229, 233, 241, 271, 272, 274, 275, 284
Toilet accessories	133, 135, 136, 138, 139, 141, 144, 147, 149, 159, 166, 171, 218
Toilet facilities	129, 131, 132, 137, 142, 147, 173, 189, 233
Toilet stalls	14, 132, 133, 141, 142, 143, 144, 145, 148, 149
Universal Accessible Built Environment (UABE)	9, 10, 15, 28
Urinals	131, 133, 137, 141, 155, 156, 157, 158, 173, 218
Vending and ticketing machines	219
Viewing spaces at fixed seating	200
Visual alarms	175, 246, 247, 251, 267
Waiting and queuing areas	196, 198
Washbasins	132, 133, 134, 136, 141, 144, 152, 153, 154, 160, 218
Washroom accessories	(See Toilet accessories)
Water closet	131, 133, 138, 141, 143, 144, 148, 149, 218
Way finding	(See Signage)
Wheelchair lift	(See Platform lifts)
Windows, glazed screens and sidelights	78, 83, 125, 126, 175, 195, 218, 273



Appendix G

Universal Accessibility Built Environment Checklist

These checklists have been compiled based on the technical requirements of the current draft guidelines, as listed in the Table of Contents. It should be noted that these are draft guidelines, subject to validation through on-site verification across KSA. In support of this validation process, users of the checklists are encouraged to provide comments and suggestions to the Prince Salman Centre for Disability Research using the Feedback Form in Appendix E.





Exterior Environments Checklist							
Guideline Reference	Page No.	Element	Compliance Status				Comments
			Yes	No	Partial	N/A	
3.1 EXTERIOR ELEMENTS							
3.1.1	30	Ground Surfaces					
3.1.2	33	Overhead and Protruding Objects					
3.1.3	36	Sidewalks, Pavements, Paths & Routes					
3.1.4	39	Exterior Ramps					
3.1.5	45	Exterior Stairs					
3.1.6	49	Kerb Cuts					
3.1.7	54	Pedestrian Crossings					
3.1.8	57	Medians and Middle Islands					
3.1.9	59	Vehicle Parking					
3.1.10	67	Passenger Drop-off Area					
3.1.11	70	Landscaping Materials & Plantings					
3.1.12	73	Street Furniture					
3.1.13	76	Gates and Turnstiles					
3.1.14	79	Courtyards and Balconies					



Exterior Environments Checklist

Guideline Reference	Page No.	Element	Compliance Status				Comments
			Yes	No	Partial	N/A	
3.3 AMENITIES							
3.3.1	196	Information, Reception & Service Counters					
3.3.2	198	Queuing and Waiting Areas					
3.3.3	200	Viewing Spaces at Fixed Seating					
3.3.4	204	Raised Platforms and Stages					
3.3.5	206	Speaker Podiums & Lecterns					
3.3.6	207	Tables, Counters & Work Surfaces					
3.3.7	209	Rest Areas and Benches					
3.3.8	212	Lockers & Baggage Storage					
3.3.9	214	Storage, Shelving & Display Units					
3.3.10	216	Controls & Operating Mechanisms					
3.3.11	219	Ticketing and Vending Machines					
3.3.12	221	Drinking Fountains					
3.3.13	225	Handrails					



Exterior Environments Checklist

Guideline Reference	Page No.	Element	Compliance Status				Comments
			Yes	No	Partial	N/A	
3.4 COMMUNICATION AND SAFETY SYSTEMS							
3.4.1	229	Signage					
3.4.2	234	Public Telephones					
3.4.3	238	Public Address Systems					
3.4.4	239	Information Systems					
3.4.5	240	Card Access, Safety and Security Systems					
3.4.6	242	Detectable Warning Surfaces					
3.4.7	244	Assistive Listening Systems					
3.5 BUILDING-SPECIFIC REQUIREMENTS							
3.5.1	252	Mosques					
3.5.2	253	Office and Retail					
3.5.3	255	Libraries					
3.5.4	259	Indoor Recreational Facilities, Halls & Stadiums					
3.5.5	260	Outdoor Recreational Facilities					
3.5.6	263	Swimming Pools					



Exterior Environments Checklist							
Guideline Reference	Page No.	Element	Compliance Status				Comments
			Yes	No	Partial	N/A	
3.5 BUILDING-SPECIFIC REQUIREMENTS							
3.5.7	266	Police Stations					
3.5.8	268	Courthouses					
3.5.9	271	Housing					
3.2 INTERIOR ELEMENTS							
3.2.1	81	Entrances					
3.2.2	84	Routes, Corridors and Access Aisles					
3.2.3	88	Interior Ramps					
3.2.4	94	Interior Stairs					
3.2.5	98	Escalators					
3.2.6	99	Lifts					
3.2.7	107	Inclined and Vertical Platform Lifts					
3.2.8	111	Moving Walks					
3.2.9	116	Doors					
3.2.10	126	Windows, Glazed Screens and Sidelights					
3.2.11	129	Toilet Facilities					



Interior Environments Checklist

Guideline Reference	Page No.	Element	Compliance Status				Comments
			Yes	No	Partial	N/A	
3.2 INTERIOR ELEMENTS							
3.2.12	134	Ablution Spaces					
3.2.13	137	Family Toilet Room					
3.2.14	142	Toilet Stalls					
3.2.15	148	Water Closets (WC)					
3.2.16	152	Washbasins					
3.2.17	155	Urinals					
3.2.18	159	Toilet Accessories					
3.2.19	162	Bathtubs					
3.2.20	167	Showers					
3.2.21	172	Grab Bars					
3.2.22	174	Offices, Work Areas and Meeting Rooms					
3.2.23	176	Kitchens and Kitchenettes					
3.2.24	184	Dressing Rooms					
3.2.25	188	Floor Surfaces					
3.2.26	190	Overhanging and Protruding Objects					
3.2.27	194	Gates, Turnstiles and Openings					



Interior Environments Checklist							
Guideline Reference	Page No.	Element	Compliance Status				Comments
			Yes	No	Partial	N/A	
3.3 AMENITIES							
3.3.1	196	Information, Reception & Service Counters					
3.3.2	198	Queuing and Waiting Areas					
3.3.3	200	Viewing Spaces at Fixed Seating					
3.3.4	204	Raised Platforms and Stages					
3.3.5	206	Speaker Podiums & Lecterns					
3.3.6	207	Tables, Counters and Work Surfaces					
3.3.7	209	Rest Areas and Benches					
3.3.8	212	Lockers & Baggage Storage					
3.3.9	214	Storage, Shelving and Display Units					
3.3.10	216	Controls and Operating Mechanisms					
3.3.11	219	Ticketing and Vending Machines					
3.3.12	221	Drinking Fountains					
3.3.13	225	Handrails					



Interior Environments Checklist							
Guideline Reference	Page No.	Element	Compliance Status				Comments
			Yes	No	Partial	N/A	
3.4 COMMUNICATION AND SAFETY SYSTEMS							
3.4.1	229	Signage					
3.4.2	234	Public Telephones					
3.4.3	238	Public Address Systems					
3.4.4	239	Information Systems					
3.4.5	240	Card Access, Safety and Security Systems					
3.4.6	242	Detectable Warning Surfaces					
3.4.7	244	Assistive Listening Systems					
3.4.8	246	Visual Alarms					
3.4.9	248	Emergency Exits, Areas of Rescue Assistance & Fire Evacuation					



Interior Environments Checklist

Guideline Reference	Page No.	Element	Compliance Status				Comments
			Yes	No	Partial	N/A	
3.5 BUILDING-SPECIFIC REQUIREMENTS							
3.5.1	252	Mosques					
3.5.2	253	Office and Retail					
3.5.3	255	Libraries					
3.5.4	259	Indoor Recreational Facilities, Halls & Stadiums					
3.5.5	260	Outdoor Recreational Facilities					
3.5.6	263	Swimming Pools					
3.5.7	266	Police Stations					
3.5.8	268	Courthouses					
3.5.9	271	Housing					



Appendix H Feedback Form

Suggested changes to the Universal Accessibility Built Environment Guidelines Manual

Please mail your comments/changes to:



مركز الأمير سلمان لأبحاث الإعاقة
Prince Salman Center For Disability Research
علم ينفع الناس Science Benefiting People

P.O.Box 94682 Riyadh 11614
Kingdom of Saudi Arabia

Name

Address

Organization

Telephone

e-mail

Proposed Change

Please identify the Section Number and Page Number related to the proposed change(s). Also include proposed new or revised wording, or identification of wording to be deleted.

Reason for Change

(attach additional sheets if required)